

Changes for the Better

MITSUBISHI CNC

Instruction Manual

E70 Series







Introduction

This manual is referred to when using the MITSUBISHI CNC E70 Series.

This manual explains how to operate, run and set up this NC unit. Read this manual thoroughly before using the NC unit. To safely use this NC unit, thoroughly study the "Precautions for Safety" on the next page before use.

Details described in this manual

CAUTION



-  For items described as "Restrictions" or "Usable State" in this manual, the instruction manual issued by the machine tool builder takes precedence over this manual.
-  Items not described in this manual must be interpreted as "not possible".
-  This manual is written on the assumption that all option functions are added. Confirm with the specifications issued by the machine tool builder before starting use.
-  Refer to the Instruction Manual issued by each machine tool builder for details on each machine tool.
-  Some screens and functions may differ depending on the NC system (or its version), and some functions may not be possible. Please confirm the specifications before use.

Refer to the following documents.

MITSUBISHI CNC E70 Series Programming Manual (Machining Center System)IB-1501200
MITSUBISHI CNC E70 Series Programming Manual (Lathe System)IB-1501193





Precautions for Safety

Always read the specifications issued by the machine tool builder, this manual, related manuals and attached documents before installation, operation, programming, maintenance or inspection to ensure correct use. Understand this numerical controller, safety items and cautions before using the unit. This manual ranks the safety precautions into "DANGER", "WARNING" and "CAUTION".











 DANGER When the user may be subject to imminent fatalities or major injuries if handling is mistaken.
 WARNING When the user may be subject to fatalities or major injuries if handling is mistaken.
 CAUTION When the user may be subject to bodily injury or when physical damage may occur if handling is mistaken.

Note that even items ranked as "  CAUTION", may lead to major results depending on the situation. In any case, important information that must always be observed is described.

The following signs indicate prohibition and compulsory.

	This sign indicates prohibited behavior (must not do). For example,  indicates "Keep fire away".
	This sign indicates a thing that is compulsory (must do). For example,  indicates "it must be grounded".

The meaning of each pictorial sign is as follows.

 CAUTION	 CAUTION rotated object	 CAUTION HOT	 Danger Electric shock risk	 Danger explosive
 Prohibited	 Disassembly is prohibited	 KEEP FIRE AWAY	 General instruction	 Earth ground

For Safe Use

Mitsubishi CNC is designed and manufactured solely for applications to machine tools to be used for industrial purposes.



Do not use this product in any applications other than those specified above, especially those which are substantially influential on the public interest or which are expected to have significant influence on human lives or properties.

DANGER

Not applicable in this manual.





WARNING

1. Items related to operation

-  If the operation start position is set in a block which is in the middle of the program and the program is started, the program before the set block is not executed. Please confirm that G and F modal and coordinate values are appropriate. If there are coordinate system shift commands or M, S, T and B commands before the block set as the start position, carry out the required commands using the MDI, etc. If the program is run from the set block without carrying out these operations, there is a danger of interference with the machine or of machine operation at an unexpected speed, which may result in breakage of tools or machine tool or may cause damage to the operators.
-  Under the constant surface speed control (during G96 modal), if the axis targeted for the constant surface speed control moves toward the spindle center, the spindle rotation speed will increase and may exceed the allowable speed of the workpiece or chuck, etc. In this case, the workpiece, etc. may jump out during machining, which may result in breakage of tools or machine tool or may cause damage to the operators.

CAUTION



1. Items related to product and manual

-  For items described as "Restrictions" or "Usable State" in this manual, the instruction manual issued by the machine tool builder takes precedence over this manual.
-  Items not described in this manual must be interpreted as "not possible".
-  This manual is written on the assumption that all option functions are added. Confirm with the specifications issued by the machine tool builder before starting use.
-  Refer to the Instruction Manual issued by each machine tool builder for details on each machine tool.
-  Some screens and functions may differ depending on the NC system (or its version), and some functions may not be possible. Please confirm the specifications before use.

2. Items related to installation and assembly

-  Ground the signal cables to ensure stable system operation. Also ground the NC unit main frame, power distribution panel and machine to one point, so they all have the same potential.

3. Items related to preparation before use







-  Always set the stored stroke limit. Failure to set this could result in collision with the machine end.
-  Always turn the power OFF before connecting/disconnecting the I/O device cable. Failure to do so could damage the I/O device and NC unit.

[Continued on next page]



CAUTION

[Continued]





4. Items related to screen operation

-  If the tool compensation amount or workpiece coordinate system offset amount is changed during automatic operation (including during single block stop), the changes will be valid from the command in next block or after several subsequent blocks.
-  All of the various data in the NC memory is erased when formatting. Be sure to use the transfer function to transfer all necessary data to another storage device before formatting.
-  Even if the tool compensation amount write command, parameter write command or variable data write command is executed with graphic check, the data will be actually written in, and the original data will be overwritten.
-  Pay close attention to the sequence operation when carrying out forced data setting (forced output) in the I/F diagnosis screen during machine operation.
-  The program including a character of any language other than the display language is not correctly displayed. Do not edit such a program. Any part of the program other than the comment part may also be changed if edited.
-  To prevent influence from data omission and data transformation in the communication circuit, always verify the data after inputting and outputting machining programs.
-  Do not change setup parameters without prior approval from the machine tool builder.

5. Items related to programming

-  Because of key chattering, etc., during editing, "NO NOS. FOLLOWING G" commands become a "G00" operation during running.
-  ";", "EOB", "%", and "EOR" are symbols used for explanation. The actual codes for ISO are "CR, LF" ("LF") and "%".
The programs created on the Edit screen are stored in the NC memory in a "CR, LF" format, however, the programs created with external devices such as the FD or RS-232C may be stored in an "LF" format. The actual codes for EIA are "EOB (End of Block)" and "EOR (End of Record)".
-  Do not change the fixed cycle program without prior approval from the machine tool builder.

6. Items related to operation



-  Stay out of the moveable range of the machine during automatic operation. During rotation, keep hands, feet and face away from the spindle.
-  Carry out dry operation before actually machining, and confirm the machining program, tool offset and workpiece coordinate system offset.
-  If the operation start position is set from a block in the program and the program is started, the program before the set block is not executed. If there are coordinate system shift commands or M, S, T, and B commands before the block set as the starting position, carry out the required commands using the MDI, etc. There is a danger of interference with the machine if the operation is started from the set starting position block without carrying out these operations.
-  Program so the mirror image function is turned ON/OFF at the mirror image center. The mirror image center will deviate if the function is turned ON/OFF at a position other than the mirror image center.

[Continued on next page]



















CAUTION

[Continued]

7. Items related to faults and abnormalities

-  If the battery low warning is issued, save the machining programs, tool data and parameters in an input/output device, and then replace the battery. When the battery alarm is issued, the machining programs, tool data and parameters may be destroyed. Reload the data after replacing the battery.
-  If the axis overruns or emits an abnormal noise, immediately press the emergency stop button and stop the axis movement.

8. Items related to maintenance

-  Incorrect connections may damage the devices, so connect the cables to the specified connectors.
-  Do not apply voltages other than those indicated according to specification on the connector. Doing so may lead to destruction or damage.
-  Do not connect or disconnect the connection cables between each unit while the power is ON.
-  Do not connect or disconnect the PCBs while the power is ON.
-  Do not connect the cable by pulling on the cable wire.
-  Do not short circuit, charge, overheat, incinerate or disassemble the battery.
-  Dispose the spent battery according to local laws.
-  Dispose the spent cooling fan according to local laws.
-  Do not replace the control unit while the power is ON.
-  Do not replace the operation panel I/O unit while the power is ON.
-  Do not replace the control section power supply PCB while the power is ON.
-  Do not replace the expansion PCB while the power is ON.
-  Do not replace the memory cassette while the power is ON.
-  Do not replace the cooling fan while the power is ON.
-  Do not replace the battery while the power is ON.
-  Be careful that metal cutting chips, etc., do not come into contact with the connector contacts of the memory cassette.
-  Do not replace the high-speed program server unit while the power is ON.
-  Before touching the unit, always touch a metal with a ground section to discharge any static electricity in the human body etc.
If static electricity is not discharged, the breakdown and the malfunction of the unit are caused.
-  When connecting to a personal computer and a unit with the RS-232/USB interface, an electric shock or a unit failure may occur.
Operate these correctly according to the manual of a unit and a personal computer.
Observe the following cautions when a personal computer in an AC power supply is used.
(1) For a personal computer that uses a 3-pin power plug or power plug with a ground lead type, make sure to use a plug socket including a ground input electrode or ground the earth lead, respectively.
(2) For a personal computer that uses a 2-pin power plug without ground lead, make sure to connect the unit to the personal computer according to the following procedures.
And, it is recommended to supply the same power supply line to a personal computer and the unit.
(a) Pull out the power plug of the personal computer from the AC outlet.
(b) Confirm that the power plug of the personal computer has been pulled out from the AC outlet, and connect RS-232/USB cables.
(c) Insert the power plug of the personal computer into the AC outlet.

Treatment of waste

The following two laws will apply when disposing of this product. Considerations must be made to each law. The following laws are in effect in Japan. Thus, when using this product overseas, the local laws will have a priority. If necessary, indicate or notify these laws to the final user of the product.

- (1) Requirements for "Law for Promotion of Effective Utilization of Resources"
 - (a) Recycle as much of this product as possible when finished with use.
 - (b) When recycling, often parts are sorted into steel scraps and electric parts, etc., and sold to scrap contractors. Mitsubishi recommends sorting the product and selling the members to appropriate contractors.

- (2) Requirements for "Law for Treatment of Waste and Cleaning"
 - (a) Mitsubishi recommends recycling and selling the product when no longer needed according to item (1) above. The user should make an effort to reduce waste in this manner.
 - (b) When disposing a product that cannot be resold, it shall be treated as a waste product.
 - (c) The treatment of industrial waste must be commissioned to a licensed industrial waste treatment contractor, and appropriate measures, including a manifest control, must be taken.
 - (d) Batteries correspond to "primary batteries", and must be disposed of according to local disposal laws.

Disposal



(Note) This symbol mark is for EU countries only.
This symbol mark is according to the directive 2006/66/EC Article 20 Information for end-users and Annex II.

Your MITSUBISHI ELECTRIC product is designed and manufactured with high quality materials and components which can be recycled and/or reused.

This symbol means that batteries and accumulators, at their end-of-life, should be disposed of separately from your household waste.

If a chemical symbol is printed beneath the symbol shown above, this chemical symbol means that the battery or accumulator contains a heavy metal at a certain concentration. This will be indicated as follows:

Hg: mercury (0,0005%), Cd: cadmium (0,002%), Pb: lead (0,004%)

In the European Union there are separate collection systems for used batteries and accumulators. Please, dispose of batteries and accumulators correctly at your local community waste collection/ recycling centre.

Please, help us to conserve the environment we live in!

Trademarks

MELDAS, MELSEC, EZSocket, EZMotion, iQ Platform, MELSOFT, GOT, CC-Link, CC-Link/LT and CC-Link IE are either trademarks or registered trademarks of Mitsubishi Electric Corporation in Japan and/or other countries.

Ethernet is a registered trademark of Xerox Corporation in the United States and/or other countries.

Microsoft® and Windows® are either trademarks or registered trademarks of Microsoft Corporation in the United States and/or other countries.

CompactFlash and CF are either trademarks or registered trademarks of SanDisk Corporation in the United States and/or other countries.

UNIX is a registered trademark of The Open Group in the United States and/or other countries.

Intel® and Pentium® are either trademarks or registered trademarks of Intel Corporation in the United States and/or other countries.

Other company and product names that appear in this manual are trademarks or registered trademarks of the respective companies.

本製品の取扱いについて

(日本語 /Japanese)

本製品は工業用 (クラス A) 電磁環境適合機器です。販売者あるいは使用者はこの点に注意し、住商業環境以外での使用をお願いいたします。

Handling of our product

(English)

This is a class A product. In a domestic environment this product may cause radio interference in which case the user may be required to take adequate measures.

본 제품의 취급에 대해서

(한국어 /Korean)

이 기기는 업무용 (A 급) 전자파적합기기로서 판매자 또는 사용자는 이 점을 주의하시기 바라며 가정외의 지역에서 사용하는 것을 목적으로 합니다.

CONTENTS

I SCREEN OPERATIONS

1 Operating the Setting and Display Unit	1
1.1 Display Unit and Keyboard Unit	2
1.2 Card Interface	5
1.2.1 Memory Card (Front IC Card) Interface	5
1.2.2 USB Memory.....	5
1.2.3 Caution	5
1.3 Screen Configuration	6
1.3.1 Operation Mode	7
1.3.2 MDI Status	7
1.3.3 Operation Status	7
1.3.4 Alarms/Warnings.....	8
1.3.5 Operation Messages.....	8
1.4 Screen Transition Diagram	9
1.5 Screen Selection Procedure	10
1.6 Setting Data	11
1.6.1 Setting Numerals and Alphabetic Characters	11
1.6.2 Inputting Operations.....	13
1.7 Operating the Screen.....	15
1.7.1 Changing the Menu.....	15
1.7.2 Types of Menus	15
1.8 Menu List	16
1.8.1 Displaying the Menu Function Outline	18
1.8.2 Directly Moving to the Menu Function.....	18
1.9 Guidance Function.....	19
1.9.1 Operation/Parameter Guidance	19
1.9.2 Alarm Guidance	24
1.10 Screen Saver (Backlight OFF) Function	27
1.10.1 Backlight OFF	27
1.10.2 Backlight ON	28
1.11 Screen Capture.....	29
1.12 Menu Customization Function	30
2 Monitor Screens.....	33
2.1 Screen Configuration	35
2.1.1 Counter Display	39
2.1.2 Switching the Counter Types.....	40
2.1.3 Changing Between <Auto/MDI> and <Manual>	41
2.2 Operation Search.....	42
2.2.1 Executing an Operation Search.....	44
2.2.2 Changing Whether to Show or Hide the Comment Field.....	45
2.2.3 Changing the Sorting Method	46
2.3 Restart Search.....	47
2.3.1 Main Screen.....	50
2.3.2 Top Search Screen.....	52
2.3.3 File Setting Screen.....	53
2.3.4 MSTB History Screen	54
2.3.5 Operation Sequence for Program Restart	55
2.3.6 Executing Restart Search (Restart Type 1)	57
2.3.7 Executing Restart Search (Restart Type 2)	58
2.3.8 Changing the Device.....	59
2.3.9 Changing the Directory with the Main Screen.....	60
2.3.10 Returning to the Restart Position	60
2.3.11 Executing the MSTB Commands.....	63
2.4 Program Edit.....	64
2.4.1 Edit/Search window	65
2.5 Trace.....	68

2.5.1	Displaying the Machine Position Trace	71
2.5.2	Canceling the Machine Position Trace	71
2.5.3	Changing the Display Range	72
2.5.4	Changing the Display Mode	74
2.5.5	Changing the Display Angle	75
2.5.6	Switching the Axis Movement Direction (+, -)	75
2.5.7	Switching the Full-screen Display Mode	76
2.5.8	Precautions for Tracing	76
2.6	Program Check (2D)	77
2.7	Counter All-axis Display	78
2.8	Tool Compensation Amount	80
2.9	Workpiece Coordinate System Compensation	84
2.10	Counter Setting	85
2.11	Origin Set, Origin Cancel	87
2.12	Manual Numerical Value Command	89
2.13	Modal Display	91
2.14	Program Tree Display	94
2.15	Integrated Time Display	95
2.15.1	Setting the Integrated Time	96
2.15.2	Setting the Time Display Selection	97
2.16	Common Variables	98
2.16.1	Setting Common Variables	100
2.16.2	Copying/Pasting Common Variables	100
2.16.3	Erasing Common Variables	101
2.16.4	Switching the Display Area	101
2.17	Local Variables	102
2.17.1	Displaying the Arbitrary Local Variables	104
2.18	Buffer Correction	105
2.19	PLC Switch Function	109
2.19.1	Turning PLC Switches ON/OFF	110
2.20	Load Meter Display	111
2.21	Spindle, Standby Display	112
2.22	All Spindles' Rotation Speed Display	113
3	Setup Screens	115
3.1	Screen Configuration	116
3.2	Tool Compensation Amount	118
3.2.1	Tool Compensation Amount (M system)	119
3.2.1.1	Setting the Tool Compensation Data	122
3.2.1.2	Switching the Input Method for the Tool Compensation Data	124
3.2.1.3	Erasing the Tool Compensation Data	125
3.2.1.4	Copying/Pasting the Tool Compensation Data	126
3.2.1.5	Disabling the setting of tool compensation amount	126
3.2.2	Tool Compensation Amount (L system)	127
3.2.2.1	Wear Data	127
3.2.2.2	Tool Length Data	130
3.2.2.3	Tool Nose Data	132
3.2.2.4	Operation Method	134
3.2.2.5	Disabling the Setting of Tool Compensation Amount	137
3.3	Tool Measurement	138
3.3.1	Tool Measurement (M system)	138
3.3.2	Tool Measurement (L system)	144
3.4	Tool Registration	163
3.4.1	Registering a Tool in the Magazine Pot	165
3.4.2	Setting the PLC Command	166
3.4.3	Setting/Erasing the Tool No. of Spindle/Standby Tools	166
3.4.4	Erasing the Tool Registration Data	167
3.5	Tool Life Management	168
3.5.1	Displaying the Group List (M system: Tool life management I, II / L system: Tool life management II)	170
3.5.2	Displaying the Life Management Data in Group Units (M system)	174
3.5.3	Displaying the Life Management Data (L system: Tool life management I)	181

3.5.4 Displaying the Tool Life Management Data in Group Units (L system: Tool life Management II).....	183
3.6 Workpiece Coordinate System Offset.....	188
3.6.1 Setting the Coordinate System Offset Amount	190
3.6.2 Erasing the Coordinate System Offset Amount	190
3.6.3 Setting the Workpiece Coordinate Origin.....	191
3.6.4 Changing the Coordinate System Display	191
3.7 User Parameters.....	192
3.7.1 Setting the Parameters	194
3.7.2 Copying/Pasting Parameters	194
3.7.3 Parameter Configuration.....	196
3.7.4 Echoback.....	196
3.7.5 Ethernet Parameter Password.....	196
3.8 MDI Program Editing.....	197
3.9 Counter Setting.....	198
3.10 Manual Numerical Value Commands	199
3.11 T Code List.....	200
4 Edit Screens	203
4.1 Screen Configuration	204
4.2 Program Editing	205
4.2.1 Creating a New Machining Program	208
4.2.2 Editing a Machining Program.....	209
4.2.3 Editing MDI Program.....	211
4.2.4 Registering MDI Program in NC Memory	212
4.2.5 Erasing a File	213
4.2.6 Editing Operations	213
4.2.7 Changing the Display.....	214
4.2.8 Displaying an Arbitrary Line	215
4.2.9 Rewriting Data	216
4.2.10 Inserting Data.....	216
4.2.11 Deleting Data	217
4.2.12 Searching for Character Strings.....	219
4.2.13 Replacing Character Strings.....	221
4.2.14 Copying/Pasting Data	222
4.2.15 Adding Sequence No. (N No.) Automatically	223
4.2.16 G Code Guidance	226
4.2.17 Playback Editing (M system).....	229
4.3 Program Check (2D)	233
4.3.1 Checking Continuously	237
4.3.2 Checking One Block at a Time	239
4.3.3 Canceling the Program Check.....	240
4.3.4 Setting the coordinate system to draw.....	240
4.3.5 Drawing during a Program Check.....	243
4.3.6 Changing the Display Range	243
4.3.7 Changing the Display Mode.....	245
4.3.8 Changing the Display Angle.....	246
4.3.9 Switching the Axis Movement Direction (+, -)	247
4.3.10 Switching to Full-screen Display Mode	248
4.3.11 Setting Auto Graphic.....	249
4.3.12 Availability of Check Mode with Other Functions.....	252
4.3.13 Handling of Variable Commands, Programmable Parameter Input, and Programmable Compensation Data Input.....	253
4.3.14 Switching the Draw Path.....	254
4.3.15 Notes for Program Check (2D)	255
4.4 Program Input/Output	256
4.4.1 Changing the Valid Area	260
4.4.2 Selecting a Device, Directory, and File.....	261
4.4.3 Transferring a File.....	265
4.4.4 Comparing Files (Compare).....	268
4.4.5 Erasing a File	269
4.4.6 Changing a File Name (Rename)	270

4.4.7	Creating a Directory	271
4.4.8	Merging a File	272
4.4.9	Formatting an External Device.....	273
4.4.10	List of File Names	273
4.4.11	Edit Lock B and C	274
4.4.12	Program Display Lock C	275
4.4.13	Data Protect Keys	276
4.4.14	The Batch Input/Output the Machining Program of NC Memory	277
4.4.15	Leading Zero.....	282
5	Diagnosis Screens	285
5.1	System Configuration Screen	286
5.2	Option Display Screen	289
5.3	I/F Diagnosis Screen.....	290
5.3.1	Displaying the PLC Device Data.....	293
5.3.2	Carrying Out Modal Output	294
5.3.3	Carrying Out One-shot Output	295
5.4	Drive Monitor Screen	296
5.4.1	Servo Axis Unit Display Items	297
5.4.2	Spindle Unit Display Items	300
5.4.3	Display Items for the Power Supply Unit.....	303
5.4.4	Clearing the Alarm History	304
5.5	NC Memory Diagnosis Screen (NC Memory Diagn Screen)	305
5.5.1	Writing/Reading the Data Using the NC Data Designation.....	307
5.6	Alarm Screen	308
5.6.1	Alarm History	310
5.7	Self Diagnosis Screen.....	312
5.8	Data Sampling Screen	315
5.8.1	Sampling Parameter	317
5.8.1.1	Sampling Address.....	320
5.8.2	Executing NC Data Sampling	323
5.8.3	Outputting Sampling Data.....	324
6	Maintenance Screens	327
6.1	Parameter Screens	330
6.1.1	Changing the Parameter Display	335
6.1.2	Setting the Parameters	335
6.1.3	Copying/Pasting Parameters	337
6.1.4	User Parameters	338
6.1.5	Echo Back.....	339
6.2	Input/Output Screen.....	340
6.2.1	Changing the Valid Area	343
6.2.2	Selecting a Device, Directory and File	344
6.2.3	Transferring a File.....	351
6.2.4	Comparing Files (Compare).....	354
6.2.5	Erasing a File	355
6.2.6	Changing a File Name (Rename)	355
6.2.7	Creating a Directory	356
6.2.8	Merging a File	357
6.2.9	Formatting an External Device.....	358
6.2.10	List of File Names	359
6.2.11	Edit Lock B and C	368
6.2.12	Data Protect Keys	369
6.2.13	Sharing Machining Data.....	371
6.2.14	The Batch Input/Output the Machining Program of NC Memory	373
6.3	All Backup Screen.....	378
6.3.1	Performing a Backup Operation	380
6.3.2	Performing a Restore Operation	380
6.4	System Setup Screen	381
6.4.1	Writing Initial Parameters.....	383
6.5	Adjust S-analog Screen	384
6.5.1	Adjustment Preparations.....	385

6.5.2 Performing Automatic Adjustments.....	386
6.5.3 Performing Manual Adjustments.....	386
6.6 Absolute Position Setting Screen.....	388
6.6.1 Selecting the Axis	390
6.6.2 Carrying Out Dogless-type Zero Point Initialization	391
6.6.3 Carrying Out Dog-type Zero Point Initialization.....	399
6.6.4 Precautions	399
6.7 Servo Diagnosis Screen	401
6.8 Diagnosis Data Collection Setting Screen	404
6.8.1 Performing a Data Collection Operation	406
6.8.2 Stopping a Data Collection Operation.....	406
6.8.3 Clearing a Collected Data	406

II MACHINE OPERATIONS

1 Operation State	3
1.1 Operation State Correlation Diagram.....	4
1.2 Power OFF.....	4
1.3 Operations Not Ready	5
1.4 Operations Ready	5
1.4.1 Reset	5
1.4.2 Automatic Operation in Progress	5
1.4.3 Automatic Operation Pause	5
1.4.4 Automatic Operation Stop.....	6
2 Indicator Lamps	7
2.1 Control Unit Ready.....	8
2.2 In Automatic Operation	8
2.3 Automatic Operation Start Busy.....	8
2.4 Automatic Operation Pause Busy	8
2.5 Return to Reference Position.....	8
2.6 Alarm.....	8
2.7 M00	8
2.8 M02/M30	8
3 Reset Switch and Emergency Stop Button	9
3.1 Reset Switch	10
3.2 Emergency Stop Button	10
4 Operation Mode.....	11
4.1 Mode Selection Switch.....	12
4.2 Jog Feed Mode	12
4.3 Rapid Traverse Feed Mode	13
4.4 Manual Reference Position Return Mode	14
4.4.1 Outline	14
4.4.2 Detailed Description.....	14
4.4.3 Clear the Shift Amount for Coordinate System Setting When Manually Returning to the Reference Position	16
4.5 Incremental Feed Mode	17
4.6 Handle Feed Mode	17
4.7 Memory Mode	18
4.8 MDI Operation Mode.....	18
5 Operation Panel Switches in Operation Mode	19
5.1 Rapid Traverse Override.....	20
5.2 Cutting Feed Override.....	20
5.3 Spindle Override	20
5.4 Manual Feedrate	21
5.5 Handle/Incremental Feed Magnification	21
5.6 Handle Feed Axis Selection.....	21
5.7 Manual Pulse Generator	22
5.8 Cycle Start and Feed Hold.....	22
5.9 Feed Axis Selection	22

6	Operation Panel Switch Functions	23
6.1	Chamfering.....	24
6.2	Miscellaneous Function Lock.....	24
6.3	Single Block	24
6.4	Z Axis Cancel.....	24
6.5	Dry Run.....	24
6.6	Manual Override.....	24
6.7	Override Cancel	24
6.8	Optional Stop	25
6.9	Optional Block Skip.....	25
6.10	Manual Absolute	26
6.11	Mirror Image.....	27
6.12	Error Detect.....	27
6.13	Follow-up Function.....	28
6.14	Axis Removal	28
6.15	F 1-digit Feed.....	29
6.15.1	Outline.....	29
6.15.2	Detailed Description.....	29
6.15.3	Preautions	30
6.16	Manual/Automatic Synchronous Feed	31
6.16.1	Outline.....	31
6.16.2	Conditions for Validating Manual/Automatic Synchronous Feed	31
6.16.3	Operation during manual/automatic simultaneous operation.....	32
6.16.4	Operation When Automatic Operation Commands and Manual/Automatic Simultaneous Valid Selection are Issued for Same Axis	33
6.16.5	Other Precautions	35
6.17	Handle Interruption.....	36
6.17.1	Outline.....	36
6.17.2	Interruptible Conditions	36
6.17.3	Interruption Effective Axis	36
6.17.4	Axis Movement Speed Resulting From Interruption	37
6.17.5	Path Resulting After Handle Interruption	38
6.17.6	Handle Interruption in Tool Radius Compensation	40
6.17.7	Interrupt Amount Reset.....	42
6.17.8	Operation Procedure.....	42
6.18	All Axis Machine Lock	43
6.19	Each Axis Machine Lock	43
6.20	Deceleration Check.....	44
6.20.1	Functions	44
6.20.2	Deceleration Check Method.....	45
6.20.3	Deceleration Check When Opposite Direction Movement Is Reversed.....	47
6.20.4	Parameters	48
6.20.5	Precautions	49
6.21	External Deceleration.....	51
6.21.1	Outline.....	51
6.21.2	Explanation of Function	51
6.21.3	Combination with Other Functions.....	51
6.21.4	Precautions	51
6.22	Reference Position Retract	52
6.22.1	Outline.....	52
6.22.2	Detailed Description.....	52
6.23	Spindle Orientation.....	53
6.23.1	Outline.....	53
6.23.2	Orientation Operation.....	54
7	Other Functions	57
7.1	Stored Stroke Limit.....	58
7.1.1	Stored Stroke Limit I	59
7.1.2	Stored Stroke Limit II	60
7.1.3	Stored Stroke Limit for Rotation Axis	61
7.1.4	Changing the Area for the Stored Stroke Limit I	61
7.1.5	Precautions	61

7.2 Chuck Barrier/Tailstock Barrier (L System).....	62
7.2.1 Detailed Description.....	62
7.2.2 Setting the Chuck Barrier/Tailstock Barrier.....	63
7.2.3 Restrictions.....	65
7.3 Manual Synchronous Tapping.....	66
7.3.1 Outline.....	66
7.3.2 Command Format.....	66
7.3.3 Operation Procedures.....	66
7.3.4 Precautions.....	66
7.4 System Lock.....	67
7.4.1 Detailed Description.....	67
7.4.2 Caution.....	69

III MAINTENANCE

1 Daily Maintenance and Periodic Inspection and Maintenance.....	1
1.1 Maintenance Items.....	2
1.1.1 Escutcheon.....	2
1.1.2 LCD Panel.....	2
1.1.3 Compact Flash/USB memory.....	3
2 Hardware Replacement Methods.....	5
2.1 Durable Parts.....	6
2.1.1 Control Unit Battery.....	6
2.1.2 Backlight.....	8
2.1.3 Fuse.....	10
2.1.3.1 Control Unit Protection Fuse.....	10
2.1.3.2 Operation Panel I/O Unit Protection Fuse.....	10
2.1.4 Key Sheet.....	11
2.2 Control Unit.....	12
2.2.1 Installation on FCU7-DU120-13 (8.4-type).....	14
2.3 Display Unit.....	15
2.4 Keyboard Unit.....	16
2.5 Operation Panel I/O Unit.....	17
2.6 CompactFlash (CF) Card.....	18
2.7 USB Memory.....	19

IV APPENDIXES

Appendix 1 List of Function Codes.....	1
Appendix 2 Table of Command Value Ranges.....	3
Appendix 3 Circular Cutting Radius Error.....	11
Appendix 4 Registering/Editing the Fixed Cycle Program.....	13
Appendix 4.1 Fixed Cycle Operation Parameters.....	14
Appendix 4.2 Transmitting/Erasing the Fixed Cycle Program.....	14
Appendix 4.3 Standard Fixed Cycle Subprogram (For L system).....	15
Appendix 4.4 Standard Fixed Cycle Subprogram (For M system).....	22
Appendix 5 RS-232C I/O Device Parameter Setting Examples.....	29
Appendix 6 Explanation of Alarms.....	31
Appendix 6.1 Operation Errors (M).....	32
Appendix 6.2 Stop Codes (T).....	52
Appendix 6.3 Servo/Spindle Alarms (S).....	58
Appendix 6.3.1 Servo Errors (S01/S03/S04).....	58
Appendix 6.3.2 Initial Parameter Errors (S02).....	73
Appendix 6.3.3 Safety Function Errors (S05).....	73
Appendix 6.3.4 Parameter Errors (S51).....	74
Appendix 6.3.5 Servo Warnings (S52).....	75
Appendix 6.3.6 Safety Function Warnings (S53).....	77
Appendix 6.4 MCP Alarms (Y).....	78
Appendix 6.5 System Alarms (Z).....	89

Appendix 6.6 Absolute Position Detection System Alarms (Z7*)	97
Appendix 6.7 Distance-coded Reference Scale Errors (Z8*)	101
Appendix 6.8 Emergency Stop Alarms (EMG)	102
Appendix 6.9 Computer Link Errors (L)	105
Appendix 6.10 User PLC Alarms (U)	106
Appendix 6.11 Network Service Errors (N)	109
Appendix 6.12 Program Errors (P)	111
Appendix 7 Operation Messages	143
Appendix 7.1 Search-related Operation Messages	144
Appendix 7.2 Graphic Display-related Operation Messages	145
Appendix 7.3 Variable (Common variables, local variables) - related Operation Messages	146
Appendix 7.4 PLC Switch-related Operation Messages	146
Appendix 7.5 Compensation-related (Tool compensation, coordinate system offset) Operation Messages	146
Appendix 7.6 Data Input/Output-related Operation Messages	147
Appendix 7.7 Parameter-related Operation Messages	150
Appendix 7.8 Measurement-related Operation Messages	151
Appendix 7.9 Tool (Tool registration, tool life) -related Operation Messages	153
Appendix 7.10 Editing-related Operation Messages	154
Appendix 7.11 Diagnosis-related Operation Messages	156
Appendix 7.12 Maintenance-related Operation Messages	157
Appendix 7.13 Data Sampling-related Operation Messages	159
Appendix 7.14 Absolute Position Detection-related Operation Messages	159
Appendix 7.15 System Setup-related Operation Messages	160
Appendix 7.16 Automatic Backup-related Operation Messages	160
Appendix 7.17 Alarm History-related Operation Messages	161
Appendix 7.18 DeviceNet-related Operation Messages	162
Appendix 7.19 Other Operation Messages	163
Appendix 8 User Parameters	165

I SCREEN OPERATIONS



Operating the Setting and Display Unit

This explains the operations and functions common to the screens.

1.1 Display Unit and Keyboard Unit

Setting display device is structured by display unit and keyboard unit. A menu key is a part of display unit. Operations such as screen transition and data setting are to be made with keyboard unit or menu keys.

The figure below is example of display unit and keyboard unit arranged sideways, but there is a vertical arrangement as well.



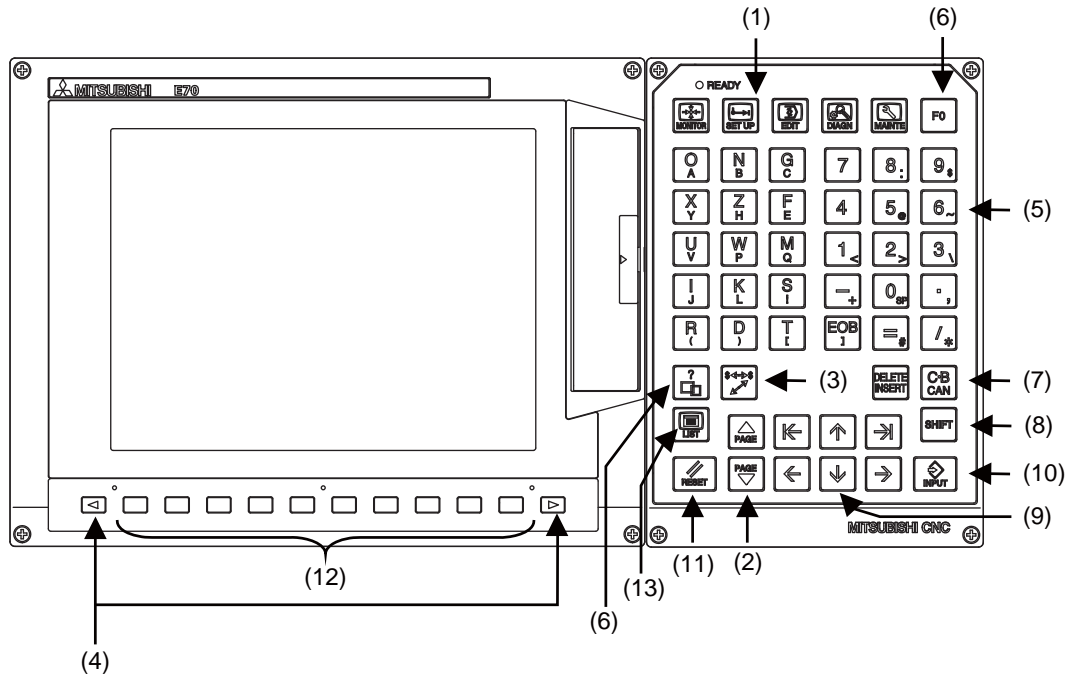







<Example of unit arrangement>

























Some models have keyboard units that are different from the above in keyboard size or arrangement, etc.

(Note) Please do not hit the key repeatedly.

The following keys are provided on the keyboard. Some keyboards may not have the keys that are shown below.

	Key type	Key	Operation
(1)	Function key (Function selection key)	 (MONITOR)	This displays the screen related to "operations". (Refer to "2. Monitor Screens".)
		 (SETUP)	This displays the screen related to "setup". (Refer to "3. Setup Screens".)
		 (EDIT)	This displays the screen related to "editing". (Refer to "4. Edit Screens".)
		 (DIAGN)	This displays the screen related to "diagnosis". (Refer to "5. Diagnosis Screens".)
		 (MAINTE)	This displays the screen related to "maintenance". (Refer to "6. Maintenance Screens".)
(2)	Page changeover key	 Previous page key	When the displayed contents cover several pages, this displays the contents of the previous page. The "▲" mark at the top of the screen indicates that there is a previous page.
		 Next page key	When the displayed contents cover several pages, this displays the contents of the next page. The "▼" mark at the top of the screen indicates that there is a next page.
(3)	Previous screen display key (Part system changeover)	 (BACK) Previous screen display key	This redisplay the previously displayed screen.
		 (\$ ↔ \$) (\$ → \$) Part system changeover key	When using a multi-part system NC, this displays the data of the next part system. The screen does not change if it is a part system common screen or when only one part system is used. E70 is one-part system control.
(4)	Menu changeover key	 (left side)	This changes the operation menu for the displayed screen to the current screen group screen selection menu. This is also used to cancel the menu operations of the displayed screen.
		 (right side)	When all of the menus cannot be displayed at once, this displays the menus not currently displayed. The "◀" and "▶" marks at the bottom of the screen indicate that there are menus not displayed.
(5)	Data setting keys	A B C D E F G H I J K L M N O P Q R S T U V W X Y Z 0 1 2 3 4 5 6 7 8 9 + - = / . ; etc.	These keys are pressed to set alphabetic characters, numerals and operation symbols, etc.

	Key type	Key	Operation
(6)	Particular keys	 Help key	This displays the operation guidance, parameter guidance and alarm guidance corresponding to the current operation.
			These key definitions differ according to the machine tool builder.
			
			
(7)	Data correction keys	 (INSERT) Data insert key	This inputs the data insertion mode. When a data setting key is pressed, a character is inserted in front of the current cursor position. The overwrite mode is entered when the [DELETE], [C.B CAN], [INPUT], cursor or TAB, etc., keys are pressed, or when the screen is changed.
		 (DELETE) Data delete key	This deletes the character just before the cursor position in the data setting area. When editing a program, the character on which the cursor is will be deleted and data after the cursor will move to the left.
		   (C.B CAN) Cancel key	This cancels the setting in the data setting area.
(8)	SHIFT key	 (SHIFT)	This validates the setting on the lower line of data key.
(9)	Cursor keys	 	This moves the cursor up or down one when setting data in the screen display items.
		 	This moves the cursor one item to the left or right when selecting data in the screen display items.  at cursor left end: Moves to the right end of previous line.  at cursor right end: Moves to left end of next line.
		 	This moves the data input cursor one character to the left or right in the data setting area.
(10)	INPUT key	 (INPUT)	This fixes the data in the data setting area, and writes it to the internal data. The cursor moves to the next position.
(11)	RESET key	 (RESET)	This resets the NC.
(12)	Menu keys		This changes the screen and displays the data.
(13)	Menu list keys	 (MenuList)	This is function that displays each screen's menu configuration as a list. (Refer to "1.7 Menu list")
(14)	Operation keys	 (SP)	This is space key.

1.2 Card Interface

There is a card interface on right side of display unit. It can use compact flash (CF) card and USB memory.

1.2.1 Memory Card (Front IC Card) Interface

It can insert compact flash (CF) card.

It can input/output Machining program data.

It can edit machining program (text file) that is stored in memory card. Also, it can load machining program that is stored in memory card.

1.2.2 USB Memory

It can insert USB memory.

It can input/output Machining program data.

It can edit machining program (text file) that is stored in USB memory, but it can not load machining program that is stored in USB memory.

Operation item	USB Memory	CF Card
Input/Output	○	○
Load	×	○
Edit	○	○
out Search of ladder.	×	○

○ : Can operate × : Can not operate

1.2.3 Caution

- (1) Do not take out CF card/USB memory when loading data.
- (2) Take time (about more than 10 seconds)when inserting/removing it after power stared.
- (3) To prevent trouble, do not remove or turn the power off when accessing to CF card/USB memory.
- (4) Do not connect other than USB memory.
- (5) Genuine CF card is recommended. There is a CF card only for Mitsubishi CNC. To buy this CF card, please contact Mitsubiswhi Electric dealer. Using open market CF card/USB memory is not guaranteed, please check operation sufficiently.

1.3 Screen Configuration

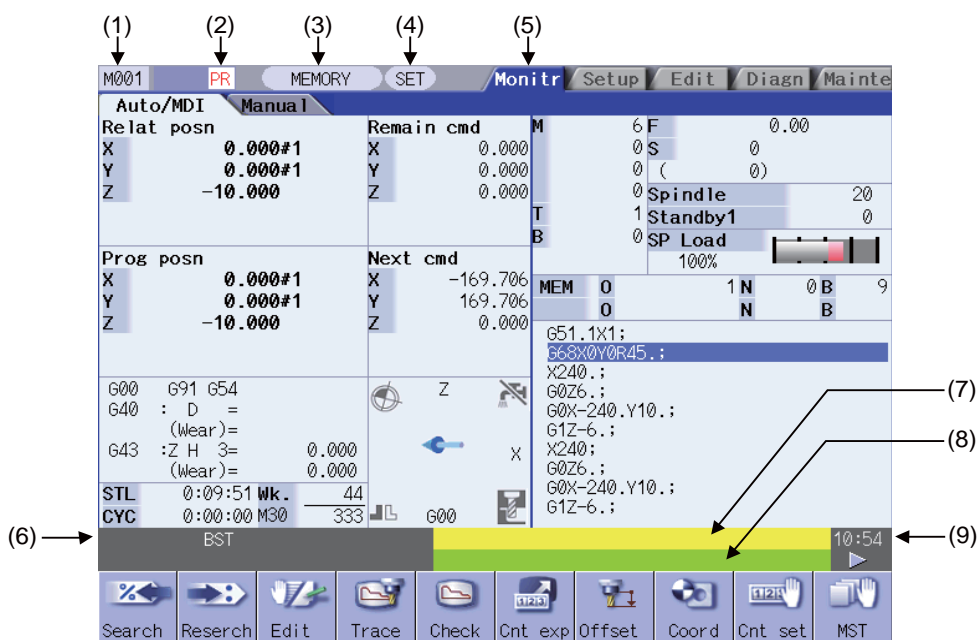

Display items

Display item	Details
(1) NC name	The currently displayed NC name (name set in parameter "#1135 unt_nm") is displayed.
(2) Power ON request	This appears if a parameter requiring the power to be turned ON again has been changed. This flickers at an approx. one-second interval.
(3) Operation status	The operation mode is displayed.
(4) MDI status	The MDI status is displayed when the MDI operation mode is selected. This does not appear when other operation modes are selected.
(5) Screen name	The tag for the currently selected screen is selected and displayed.
(6) Operation status	The NC operation status is displayed.
(7) Alarm	The currently occurring alarm or warning with the highest priority is displayed.
(8) Operation message	The operation message is displayed.
(9) Time	The current time is displayed. (Hour: minute)

1.3.1 Operation Mode

The selectable operation mode is following below.

Symbol	Details	Explanation
MEMORY	Memory operation	Automatic operation is based on programs stored in the memory.
TAPE	Tape operation	Automatic operation is based on tape command (RS232C input) programs stored in NC tape.
MDI	MDI operation	Automatic operation is performed with the program set in the MDI screen.
JOG	Jog	The jog feed mode enables the axis to be moved by hand consecutively at the feed rate set by using the MANUAL FEED RATE switch.
HANDLE	Manual handle	The handle feed mode enables the axis to be moved by turning the manual handle. The travel distance per graduation of the handle depends on how the HANDLE/INCREMENTAL MAGNIFICATION switch is set.
STEP	Step	The step feed mode enables the axis to be moved by hand at feed rate when the FEED AXIS SELECT switch is ON. The travel distance per graduation of the handle depends on how the HANDLE/INCREMENTAL MAGNIFICATION switch is set.
MANUAL	Manual arbitrary feed	This mode enables to move manually with arbitrary amount or arbitrary positioning position.
ZERO-RTN	Reference position return	This mode enables a controlled axis to be returned manually to the defined position unique to the machine (reference position).
INIT-SET	Automatic dog-less reference position return	This mode enables this mode to manually push against the machine end stopper and carry out zero point return.
RAPID	Rapid traverse	The rapid traverse feed mode enables the machine to be moved consecutively at rapid traverse feedrate manually.
NO MODE	No operation mode	The operation mode is not selected.

1.3.2 MDI Status

The MDI status is displayed when the operation mode is the MDI mode.

This does not appear when other operation modes are selected.

The displayed MDI status is following below.

Symbol	Details	Character color	Background color
NON	No MDI setting	Black	Gray
SET	MDI setting completed	Black	Gray
RUN	MDI running	Black	Gray

1.3.3 Operation Status

The operation status displays the currently selected NC operation status.

Symbol	Details	Character color	Background color
EMG	In emergency stop	Red	Dark gray
RST	Resetting NC	White	Dark gray
LSK	Paper tape reader is in label skip state	White	Dark gray
BST	In block stop	White	Dark gray
HLD	Operation halted	White	Dark gray
SYN	Synchronizing	White	Dark gray
AUT	In automatic operation	White	Dark gray
RDY	Operation completed state	Green	Dark gray

1.3.4 Alarms/Warnings

When an alarm or warning occurs, the alarm No. and alarm message character string are displayed.

(Example) Warning display

S51 Parameter error		
	Character color	Background color
Alarm	White	Red
Warning	Black	Yellow

The display format of PLC alarms and operator messages can be selected by the parameter "#11021 PLC mesg disp type".

0: Display up to the first 40 characters.

1: If text is longer than 40 characters, divide it into two and display separately. (Classification No. is displayed together)

1.3.5 Operation Messages

	Character color	Background color
Operation messages	Black	Green

The operation message can be reset by pressing any key.

The following operation messages are released even if automatic start or reset is executed.

- "Search completed"
- "Restart search is completed"
- "Top search completed"
- "MDI Set ended"

(Example)

Searching

1.4 Screen Transition Diagram

The screen is configured of operation groups.

Refer to "1.5 Screen Selection Procedures" for how to display the screens.

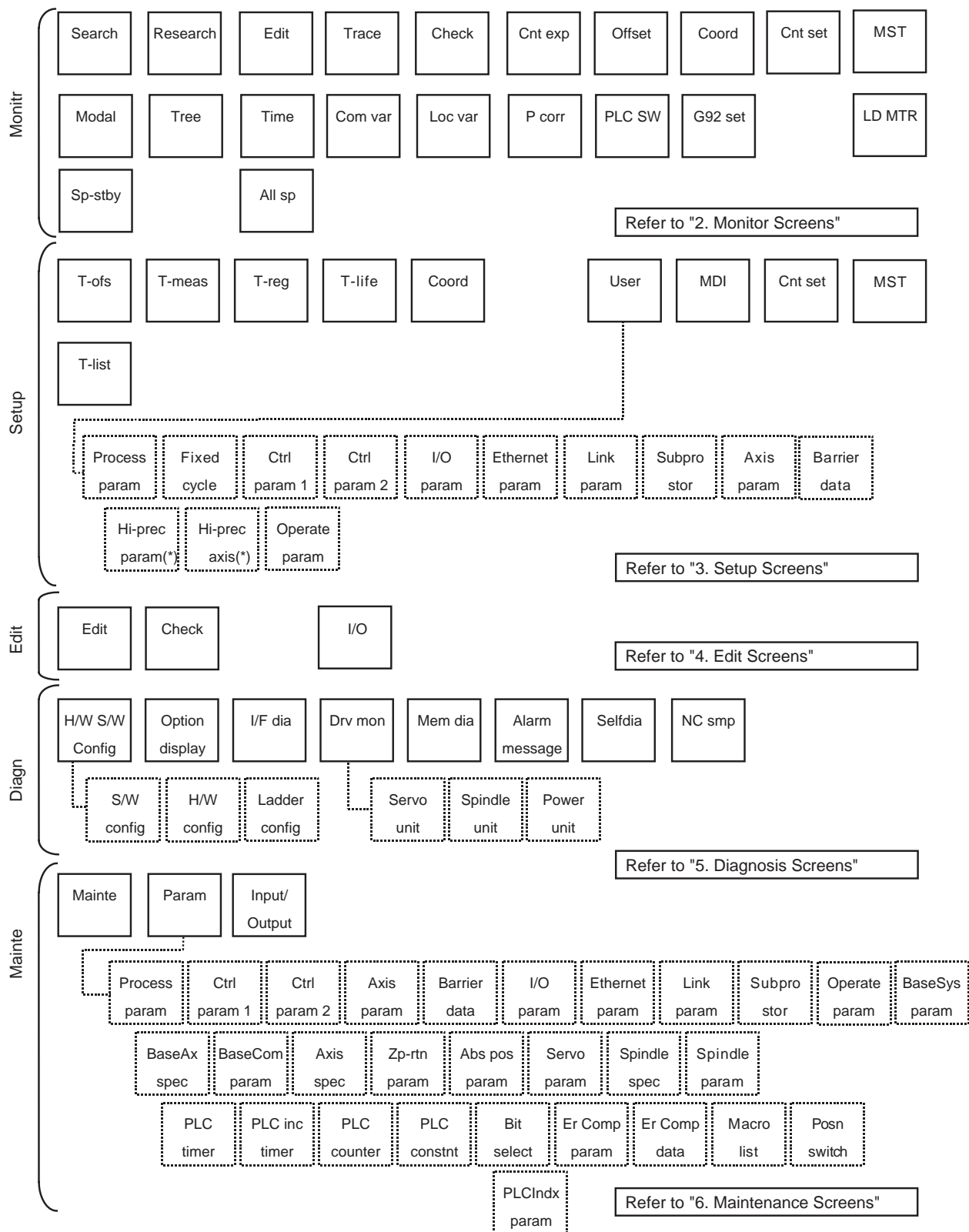

Items with (*) are not available on E70 series.

1.5 Screen Selection Procedure

The screen is selected by pressing a function key such as [MONITOR] or [SETUP], or by pressing a menu key displayed in the screen selection menu.

Operation method (To display "T-ofs" screen from the "Setup screen")

- (1) Press the function key [SETUP].



The previously displayed setup screen will appear.



The menu display will differ according to the L system/M system and parameter setting.

- (2) Press the menu [T-ofs] key.



Tool compensation amount screen appears.

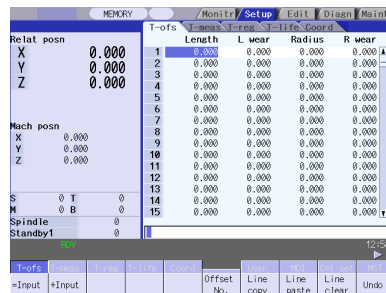

1.6 Setting Data

1.6.1 Setting Numerals and Alphabetic Characters

Operation method

The data is basically set with the following methods:

- (1) Menu selection
- (2) No. selection
- (3) Cursor movement
- (4) Data key input
- (5) [INPUT] key input

(Note 1) The contents in the data setting area are only displayed until the [INPUT] key is pressed.

These contents are invalidated if the screen is changed. The data is written into the memory when the [INPUT] key is pressed.

(Note 2) Special settings may be required depending on the data type. Refer to each item.

(Note 3) The cursor may move to the right of the display item depending on the data type.

(Note 4) If an illegal key is set, an error occurs when [INPUT] is pressed. Reset the correct data.

Operations in the data setting area

The key is input at the position where the cursor is displayed. If a cursor is not displayed, the key input is invalid.

When a key is input, the data appears at the cursor position, and the cursor moves one character space to the right.

■ [→]/[←] keys: Moves the cursor one character to the left or right.

(1) The cursor is at the position shown on the right. ➡

(2) Press the [→] key ➡ The cursor moves one character space to the right.

■ [INSERT] key: Enters the insert mode.

(1) Move the cursor to the position where the data is to be inserted. ➡ The cursor moves in the data setting area.

(2) Press the [INSERT] key, and then the data keys. ➡ The cursor moves one character space to the right.

[INSERT] [7] [7]

(Note) The overwrite mode is entered when the [DELETE], [C.B CAN] keys are pressed, or when the screen is changed.

■ [DELETE] key: Deletes the character in front of the cursor.

- (1) Move the cursor to the position where the data is to be deleted. ➡ The cursor moves in the data setting area.

123777456

- (2) Press the [DELETE] key. ➡ The character in front of the cursor is deleted, and the cursor moves.

12377456

■ [C.B] key: Deletes all characters in the data setting area.

- (1) Press the [C.B] key. ➡ The cursor moves in the data setting area.

|

Cursor operations on the screen

If a cursor is displayed on the screen, data is set in the data setting area and the [INPUT] key is pressed, the data appears at the cursor position on the screen. The cursor moves to the next position.

The following keys can be used to move the cursor with the cursor keys.

⬆: Moves the cursor to the previous line.

⬇: Moves the cursor to the next line.

⬅: Moves the cursor one item to the left.

➡: Moves the cursor one item to the right.

1.6.2 Inputting Operations

In addition to the method of directly inputting numeric data for specific data settings, a method to input the operation results using four rules operators and function symbols can be used.



Input method

Numeric values, function symbols, operators and parentheses () are combined and set in the data setting area. The operation results appear when the [INPUT] key is pressed. Data for the currently selected setting item will be set when [INPUT] key is pressed again. The contents in the data setting area are erased.

Examples of operator settings, and results		
Operation	Setting example	Operation results
Addition	=100 + 50	150
Subtraction	=100 - 50	50
Multiplication	=12.3 * 4	49.2
Division	=100 / 3	33.3333333
Function	=1.2 * (2.5 + SQRT(4))	5.4

Function symbols, setting examples and results			
Function	Function symbol	Setting example	Operation results
Absolute value	ABS	=ABS(50 - 60)	10
Square root	SQRT	=SQRT(3)	1.7320508
Sine	SIN	=SIN(30)	0.5
Cosine	COS	=COS(15)	0.9659258
Tangent	TAN	=TAN(45)	1
Arc tangent	ATAN	=ATAN(1.3)	52.431408

Operation examples

- (1) Set as shown below, and press the [INPUT] key.  The operation results appear in the data setting area.
 =12*20 [INPUT] 240
- (2) Press the [INPUT] key again.  Data for the selected setting item is set. The result is displayed on the screen. The cursor moves to the next position.

Notes for using operators and functions

Division : Zero division causes an error.

Square root : If the value in the parentheses is negative, an error occurs.

Triangle function : The unit of angle θ is degree ($^{\circ}$).

Arc tangent : $-90 < \text{operation results} < 90$.

Restrictions

- (1) Always use "=" for the first character.
- (2) Do not use the following characters as the second character or last character.
Invalid as second character: * , /,)
Invalid as last character: * , /, (, +, -
- (3) Make sure that the left parentheses and right parentheses are balanced.
- (4) The 360° limit does not apply on the angle. SIN (500) is interpreted as SIN (140).
- (5) While the Monitor screen or the Setup screen displaying, if the axis name address, M, S, T, 2nd miscellaneous function code (B, etc.) is pressed when "=" is set in data setting area as the first character, the operation input is given to priority. So, the window does not open, and the cursor does not move.
- (6) The exponential setting, like "1.23E-4", cannot be used. The operation result is not displayed with exponential.
- (7) It is not possible to set characters exceeding the number of characters which can be input to the data setting area.
- (8) It is not possible to omit "0" before the decimal point, like ".5", when operation inputting. An error will occur.
- (9) The accuracy is guaranteed for the calculation with 15 digits or less. The calculation with over 15 digits does not guarantee its accuracy.
- (10) The operator or the function which does not exist in the above-mentioned, such as "ASIN", cannot be used. The operation message "Setting error" appears, and the display of the data setting area does not change.
- (11) Regardless of the input setting unit and metric system/inch system, the digit numbers below the decimal point of the operation result is seven digits or less.

1.7 Operating the Screen

1.7.1 Changing the Menu

The menu can be used to select screens and to select functions or setting items. Up to ten menus can be displayed at once.

To select the menu, use the menu key below the menu display.

To change the menu, use the menu changeover key.

 key : The operation menu is canceled.

The screen selection menu for the currently displayed screen group appears.

The display for the currently displayed menu is highlighted.

 key : When there are more than 11 menus, this key displays the remaining menus.

This key can be used when "◀" or "▶" is displayed at the upper right of the menu.

1.7.2 Types of Menus

The menus are categorized into the following types according to the operation that takes place after the menu key is pressed.

A : The menu is highlighted, and the system waits for the user input. After the input, the operation follows the input details.

B : The menu is highlighted, and operation starts.

C : Operation starts without highlighting the menu.

In section "2. Monitor screen" and following, the types are described in the following method.

(Example) Menus used for editing the program on the Edit screen (excerpt)

Menu	Details	Type	Reference
String search	When the character string is designated and the <input type="text" value="INPUT"/> key is pressed, that character string is searched for.	A	4.2.12 Searching for character strings
String replace	If the character string to be searched for and the character string to be replaced are separated with a "/" and designated, when the <input type="text" value="INPUT"/> key is pressed, the replace operation takes place.	A	4.2.13 Replacing character strings

Operation when menu is pressed
Menu type
Reference section

1.8 Menu List

The menu list is a function that displays each screen's menu configuration as a list. The Menu list window opens when the [MenuList] key is pressed on each screen.

If a pop-up window other than the menu list is displayed, the Menu list window appears above the displayed pop-up window. The menu does not change in this case.

If the [MenuList] key is pressed again or if the [Cancel] key is pressed while the Menu list window is open, the Menu list window closes, and the state before the [MenuList] key was pressed is recovered.

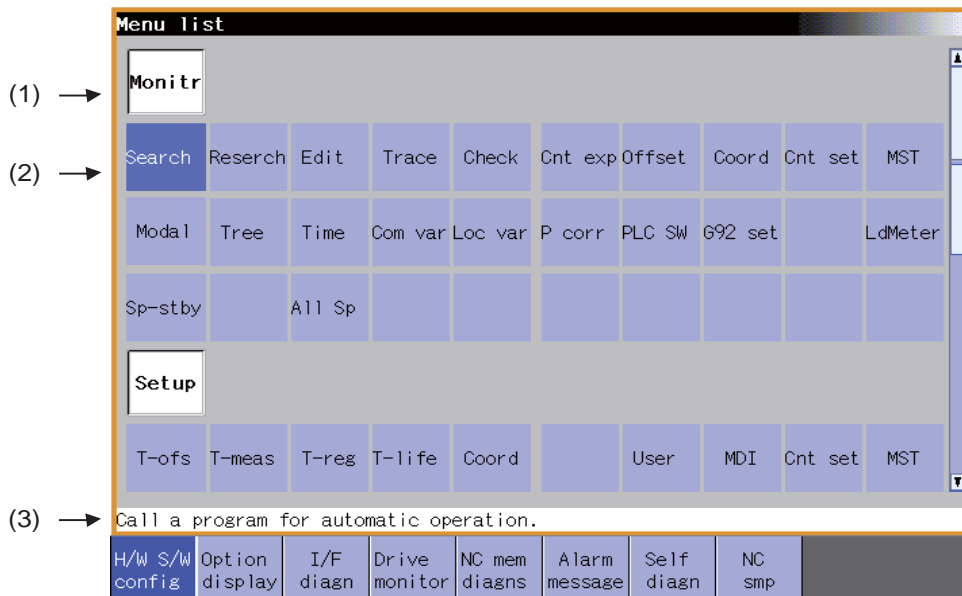

Display items

Display item	Details
(1) Screen name	The screen name is displayed. (Example) Monitr/Setup
(2) Menu name	A list of the menu names (functions) included on each screen is displayed. (Example) Search/Reserch
(3) Function outline display area	An outline of the currently selected menu name (function) is displayed.

List of menu names (functions)

Screen	Menu name	Outline
Monitr	Search	Call a program for automatic operation.
	Reserch	Restart machining from a selected block.
	Edit	Edit the machining program searched for operation.
	Trace	Trace the T path based on the machining program being executed.
	Check	Trace the T path based on the machining program w/o running machine.
	Cnt exp	Display counters of all axes & select the type of the counters.
	Offset	Set & display tool offset data.
	Coord	Set & display workpiece coordinate system offset.
	Cnt set	Set the relative position counter to an arbitrary value.
	MST	Set & display each command for S, M, T & 2nd M functions.
	Modal	Display the execution modal value of the machining program.
	Tree	Display program/MDI interrupt/user macro call in nesting structure.
	Time	Set & display integrating time (date, time, power ON time, etc.).
	Com var	Set & display the details of common variables.
	Loc var	Specify a nesting level of subprogram & display local variables.
	P corr	Correct & change the next command by block stop during auto-/MDI op.
	PLC SW	Switch ON/OFF each NC ops. control signal allocated by ladder program.
	G92 set	Perform origin set & origin cancel.
	LD MTR	Spindle load and Z axis load, etc. can be displayed in meter.
	Sp-stby	The spindle tool No. and the standby tool No. can be displayed.
All sp	Display commanded/actual rot speed values of all the spindles.	
Setup	T-ofs	Set & display tool offset data.
	T-meas	Measure T length & radius manually & set them as tool offset amounts.
	T-reg	Register T No. according to the magazine pot, spindle & wait position.
	T-life	Set and display tool usage status and other tool life management data.
	Coord	Set & display workpiece coordinate system offset.
	User	Set & display user parameters.
	MDI	Display & edit MDI programs set in NC memory.
	Cnt set	Set the relative position counter to an arbitrary value.
	MST	Set & display each command for S, M, T & 2nd M functions.
	T-list	Reference & display T-codelist.
	Pallet	The machining program is registered into the pallet of APC.
	Edit	Edit
Check		Trace the T path based on the machining program w/o running machine.
I/O		Input/Output machining programs betw. NC memory & external I/O device.
Diagn	Config	Display the H/W & S/W (S/W No. & version) configurations.
	Option	Display the details of the options registered in NC memory.
	I/F dia	Set & display input/output signals of the ladder program.
	Drv mon	Display drive diagnostic information. (servo/spindle/power supply).
	Mem dia	Set & display NC internal data.
	Alarm	Display a list of currently occurring alarms & their messages.
	Selfdia	Display the H/W & Operation stop state.
	NC Smp	Set Sampling parameter & Sample NC internal data.
Mainte	Mainte	Perform NC memory format/abs. para. setting/maint. data backup, etc.
	Param	Select a type of parameter to set & display the parameter values.
	I/O	Input/Output machining programs betw. NC memory & external I/O device.

1.8.1 Displaying the Menu Function Outline

Operation method

- | | | |
|--|---|--|
| <p>(1) Press the [MenuList] key.</p> <p>When the [MenuList] key is pressed while editing the file on the Edit screen, a prompt to confirm whether to save the program appears before Menu list window opens.</p> | ➔ | <p>The Menu list window appears showing the selected screen's menu list at the top.</p> |
| <p>(2) Using the [↑], [↓], [→], [←], and page keys, move the cursor to the menu for which the function outline is to be displayed.</p> <p>The cursor does not move to the group name.</p> | ➔ | <p>The function outline for the selected menu appears.</p> <p>The function outline does not appear if a menu with no name is selected.</p> |

Each cursor key motions are listed below.

- [↑] Key: Cursor moves up.
- [↓] Key: Cursor moves down.
- [→] Key: Cursor moves right.
- [←] Key: Cursor moves left.
- [PageDown] Key: Screen scrolls down.
- [PageUp] Key: Screen scrolls up.

(Note 1) The cursor moves in the same way even when the  key is pressed.

(Note 2) The cursor moves in the same way even when the  key is pressed.

1.8.2 Directly Moving to the Menu Function

Operation method

- | | | |
|---|---|---|
| <p>(1) Press the [MenuList] key.</p> | ➔ | <p>The Menu list window appears showing the selected screen's menu list at the top.</p> |
| <p>(2) Using the [↑], [↓], [→], [←], and page keys, move the cursor to the menu to move to.</p> | ➔ | <p>The function outline for the selected menu appears.</p> |
| <p>(3) Press the [INPUT] key.</p> | ➔ | <p>The selected menu function can be moved to directly.</p> <p>The menu is not moved to if a menu with no name is selected. The Menu list window closes after moving.</p> |

1.9 Guidance Function

1.9.1 Operation/Parameter Guidance

The parameter/operation guidance function displays the details of the parameters or the operation methods according to the state of the screen currently being displayed.

Screen configuration

The operation/parameter/alarm guidance window is displayed with the following type of configuration.

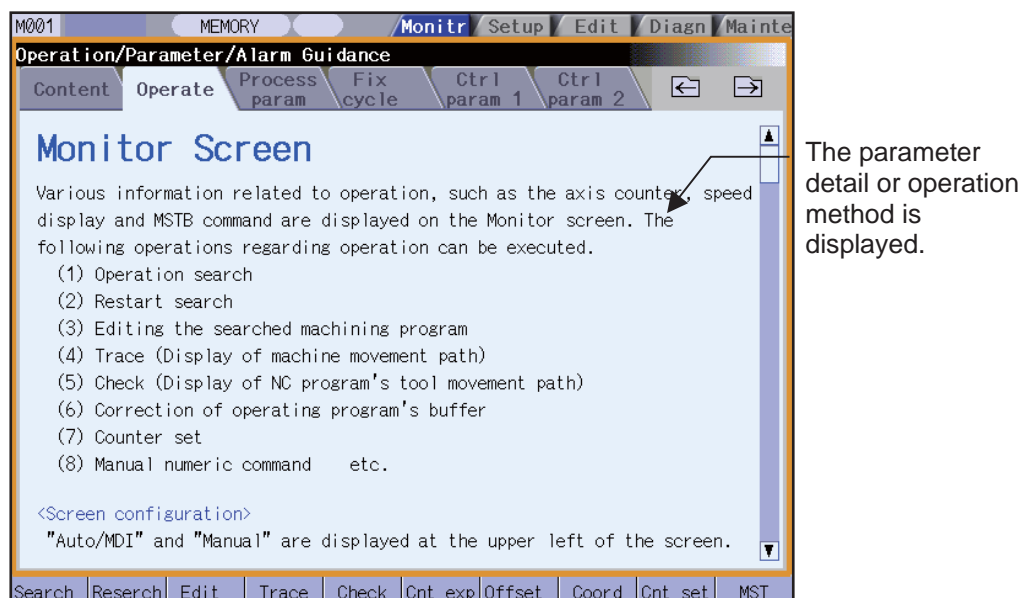

Operation method

Insert memory card with guidance data before conducting display guidance.

If the [?] key is pressed on any screen, the guidance window will open. If a pop-up window other than the guidance window is open, the guidance window will open over the currently opened pop-up window. In this case, the menu state does not change. If [?] key or [CANCEL] key is pressed again when the guidance window is open, the guidance window will close and the screen will return to the previous state in which the [?] key was pressed.

Displaying the operation guidance

(1) Press the [Edit] menu on operation screen.



The edit window is displayed.

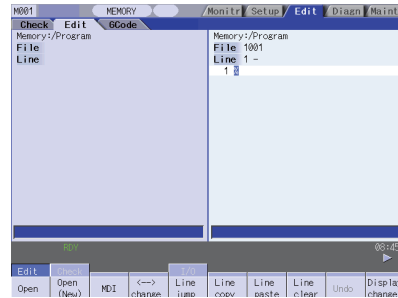

(2) Press the [?] key.



The guidance window is opened, and sub-contents for edit operation method is displayed.

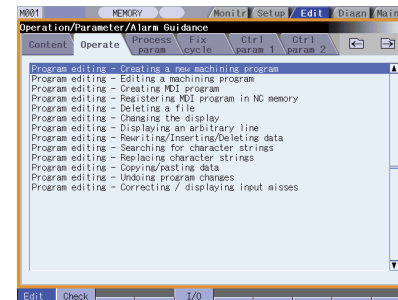

(Note) If the explanation of operation method is nothing, the contents list is displayed.

(3) Move the cursor to the operation method to be displayed by [↓], [↑], [PAGE UP], [PAGE DOWN] key.



Select the "Program editing - Undoing program changes" with the cursor.

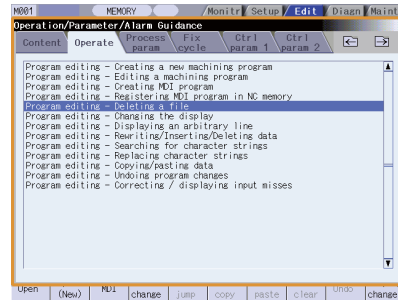

(4) Press the [INPUT] key.



The operation method for "Program editing - Undoing program changes" is displayed.

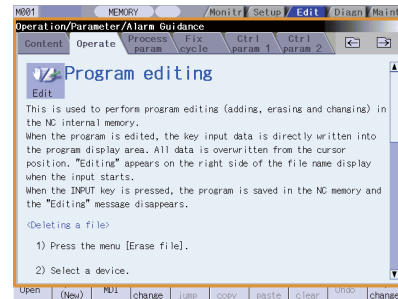

(Note 1) If the parameter tag such as machine parameter, fixed cycle, etc. is opened with the  key, the details for the top parameter are displayed.

Displaying the parameter guidance

(1) Press the [Param] menu on maintenance screen. → The machining parameter screen is displayed.

(2) Press the [↓] key, and move the cursor to "#8005 ZONE r" parameter. →

No.	Name	Data	No.	Name	Data
1026	Base axis I	X	8001	MRK COUNT M	30
1027	Base axis J	C	8002	MRK COUNT	44
1028	Base axis K	Z	8003	MRK COUNT LIMIT	333
1029	Flat axis I	X	8004	SPEED	0
1030	Flat axis J	C	8005	ZONE r	0.000
1031	Flat axis K	Z	8006	ZONE d	0.000
1084	Arc error	0.000	8007	AUTO CORNER OVR.>	0
1171	Tap return ovr	0	8008	MAX ANGLE	0
1185	Feedrate F1	0	8009	DSG_ZONE	0.000
1186	Feedrate F2	0	8010	ABS_MAX	0.000
1187	Feedrate F3	0	8011	INC_MAX	0.000
1188	Feedrate F4	0			
1189	Feedrate F5	0			
1506	F1 taper limit	100000			
1507	F1 change constant	0			

(3) Press the [?] key. →

The guidance window is opened, and the detail of "#8005 ZONE r" parameter is displayed.



Content	Operate	Process param	Link cycle	Ctrl param 1	Ctrl param 2
#8005 ZONE r					
Contents					
Set the distance between the measurement point and deceleration start point.					
Settings range					
0 to 99999.999 (mm)					

(4) Press the  key.

→ The operation method for parameter screen is displayed.

Content	Operate	Process param	Link cycle	Ctrl param 1	Ctrl param 2
Parameter screens					
The various parameters can be displayed and set on this screen.					
<Changing the parameter display>					
Changing to the computer link parameters					
1) Press the menu change key until the menu [Link param] appears.					
2) Press the menu [Link param].					
<Selecting the parameter No.>					
Selecting the parameter No.8071					
1) Press the menu [Param No.]					

(Note 1) While guidance window is displayed, the parameter details displayed on each parameter type tab are

recorded. Therefore, when the parameter type is switched with  /  key, last displayed parameter details are displayed.

(Note 2) If the parameter No. cannot be gotten (the cursor is non-display, the cursor is put on blank line, the cursor is put on comment line), the top of parameter guidance for each parameter appears.

Displaying the operation guidance by selecting the contents

(1) Press the [Search] menu on operation screen.



The operation search window is displayed.

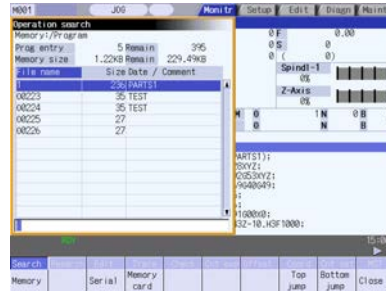

(2) Press the [?] key.



The parameter/operation guidance window is opened, and sub-contents for operation search is displayed.

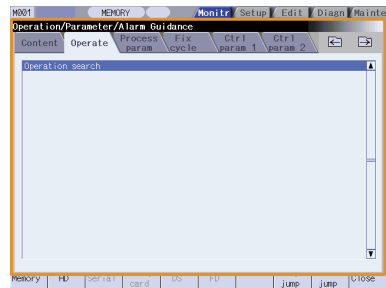



(3) Press the  key.

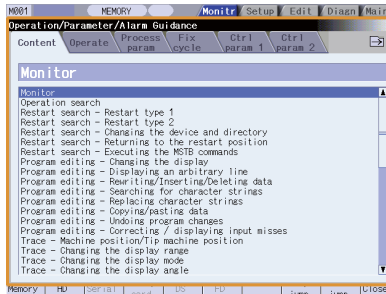

The contents for operation guidance are displayed.



- (4) Move the cursor to the operation method to be displayed by [↓], [↑], ,  keys.



Select the "Restart search - Restart type 2" with the cursor.

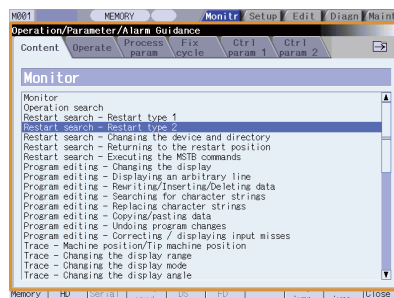

- (5) Press the [INPUT] key.



The operation method for "Restart search" is displayed.

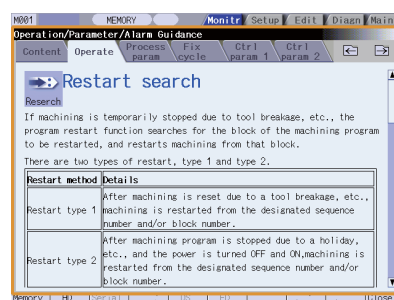

(Note 1) The operation details of function that cannot be selected because of no option are also displayed on the contents list.

(Note 2) When the  key is pressed during the contents display, the sub-contents for operation search (operation method (2)) are displayed.

Precaution

- (1) If the [?] key is pressed when alarm occurs, the alarm guidance window will open.
- (2) To display another operation method, select newly an operation method from the contents list. It is not possible to jump from the parameter, operation details to other details.
- (3) When the [?] key is pressed while the menu list window is displayed, the guidance window is opened after the menu list window is closed.
- (4) E70 loads guidance data from memory card when NC starts, but if the memory card is inserted after the NC has started, NC will load guidance data at the timing as follows.
 - (a) When operation, parameter, or alarm guidance is displayed.
 - (b) When switching display type to display G code guidance on edit screen.
 - (c) When G code guidance is displayed during display transition.

When NC is loading guidance data, "guidance data loading" message will show up, and loading will take few seconds to complete.

- (5) Once guidance data is loaded, guidance can be shown even after the memory card is removed.
- (6) When power supply is turned off guidance data will be deleted.
- (7) The instructions of parameter/operation guidance are commonly used for M700V, M70V, and E70 series. This manual is written on the assumption that all option functions are added. Confirm with the specifications manual issued by the machine tool builder before starting use.

1.9.2 Alarm Guidance

The alarm guidance is the function that displays message, details and remedy for the currently occurring alarms.

Screen configuration

The alarm guidance is displayed in "alarm" tag on "operation/parameter/alarm guidance window".

The "alarm" tag is on the rightmost end of the guidance window.

A scroll bar appears when details and remedy, etc. do not fit in one page.

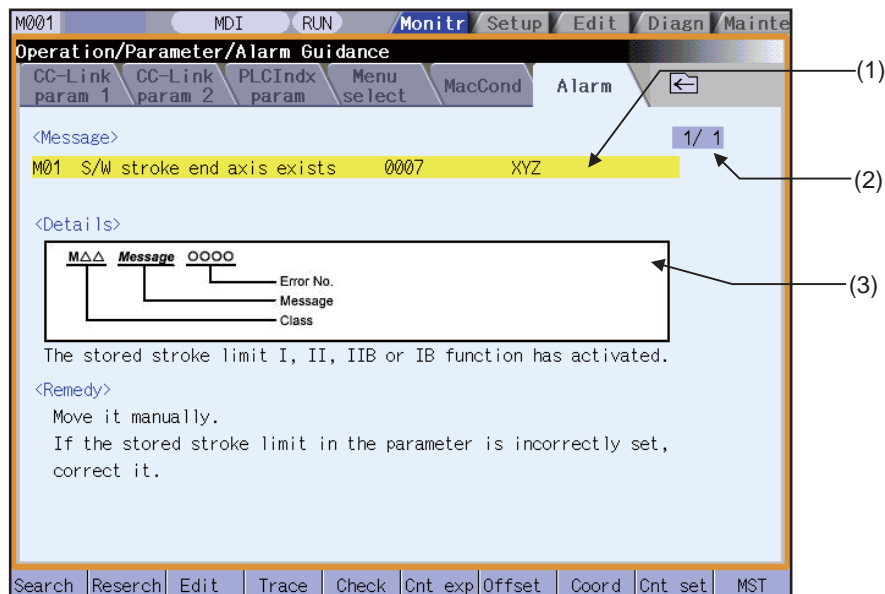

Display items

Display item	Details
(1) Message	This displays "NC alarm" and "PLC alarm message". The displayed content is same as the content displayed in the alarm message of the diagnosis screen.
(2) Number of page	This displays "order of priority / total number of occurring alarms".
(3) Details/Remedy, etc.	This displays detail and remedy, etc. for alarm message.

Operation method

If the [?] key is pressed on any screen, the alarm guidance window will open. If a pop-up window other than the alarm guidance window is open, the alarm guidance window will open over the currently opened pop-up window. In this case, the menu state does not change. If [?] key or [CANCEL] key is pressed again when the guidance window is open, the guidance window will close and the screen will return to the previous state in which the [?] key was pressed.

Displaying the alarm guidance

- (1) Press the [?] key during occurring alarm on operation screen.
(Ex.) When "H/W stroke end axis exists" and another alarm occur.



The guidance window is opened while "alarm" tag is valid. The alarm details and remedy are displayed for "H/W stroke end axis exists".

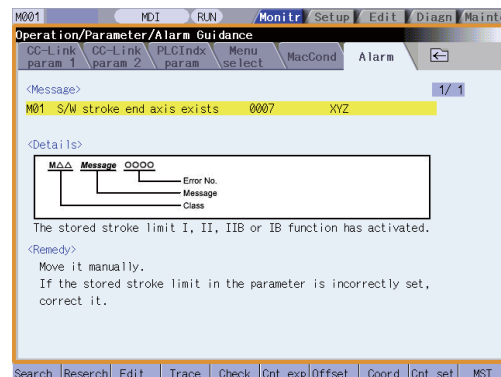

- (Note 1) The alarm guidance is executed for the alarm that is occurred when the [?] key has been pressed. Therefore, the guidance will be displayed continually even if the alarm is reset while the alarm guidance is displayed. The alarm guidance is not executed for the alarm that has occurred while the alarm guidance is displayed.
- (Note 2) If the [?] key is pressed when an alarm is not occurring, the operation/parameter guidance appears. In this state, if the "alarm" tag is selected with the right frame key, nothing is displayed in the message, details and remedy columns. (These columns are blank.)
- (Note 3) All the explanations of the alarm having the same error class and No. are displayed in the details column.

Changing the alarm guidance

- (1) Press the [→] key or [| →] key when the alarm guidance is displayed.



The alarm guidance with one priority lower than the current alarm guidance is displayed.

If the [→] key or [| →] key is pressed when the lowest priority alarm is displayed, the alarm with the highest priority is displayed.

(Ex.) When 3 alarms occur.

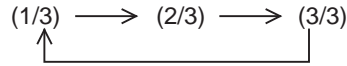

- (2) Press the [←] key or [| ←] key when the alarm guidance is displayed.



The alarm guidance with one priority higher than the current alarm guidance is displayed.

If the [←] key or [| ←] key is pressed when the highest priority alarm is displayed, the alarm with the lowest priority is displayed.

(Ex.) When 3 alarms occur.

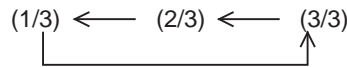

(Note 1) Up to 10 alarm guidance displays are displayed in order of priority.

(Note 2) Even if the [→], [←], [| ←] or [| →] key is pressed when only one alarm occurs, the screen display is not switched.

Precautions

- (1) While the user parameter window on "Setup" or the parameter screen on "Mainte" is displayed, the parameter guidance display will be prioritized even if [?] key is pressed when an alarm occurs.
- (2) When the [?] key is pressed while the menu list window is displayed, the guidance window is opened after the menu list window is closed.
- (3) The alarm guidance of stop code and operator message is not displayed.
- (4) The instructions of alarm guidance are commonly used for M700V, M70V, and E70 series.
This manual is written on the assumption that all option functions are added.
Confirm with the specifications manual issued by the machine tool builder before starting use.

1.10 Screen Saver (Backlight OFF) Function

The screen saver function protects the display unit by backlight OFF after the time set in the parameters has elapsed.

The backlight can also be turned OFF with key operations on the Monitor screen.

The backlight is turned ON by pressing any key.

1.10.1 Backlight OFF

The screen saver function has two types: "Automatic change function" that the backlight is turned OFF after a certain period of time, and "Manual change function" that the backlight is turned OFF by key operations.

Automatic change function

If there is no key input, no screen display request signal input from the machine within the time set in the parameter "#8078 Screen Saver Time", the backlight will be turned OFF.

If "#8078 Screen Saver Time" is set to "0", the backlight will not be turned OFF.

Manual change function

The backlight can be turned OFF by pressing the [SHIFT] and [C.B CAN] keys on the Monitor screen (when a pop-up screen is not displayed).

Even if "#8078 Screen Saver Time" is set to "0", the backlight can be turned OFF by pressing the [SHIFT] and [C.B CAN] keys.

(Note 1) Even if the [SHIFT] and [C.B CAN] keys are pressed when a screen other than the main menu is displayed on the Monitor screen (when a pop-up window is displayed), the backlight cannot be turned OFF.

(Note 2) The backlight cannot be turned OFF by the manual change function on screen other than Monitor screen.

1.10.2 Backlight ON



If a key is pressed or the screen display request signal is input while the backlight is OFF, the backlight will be turned ON.

Key operation

The correspondence when the key is pressed is as follows during backlight OFF.

- (1) Backlight ON + screen transition
(Example) Function key, [?] key, etc.
- (2) Backlight ON only
(Example) Page changeover key, Menu changeover key, Data setting keys, Data correction keys, etc.
- (3) The key input is ignored
(Example) [RESET] key, [SHIFT] key

Precautions

- (1) The backlight will not be turned ON even if the reset key is pressed. However, if the screen display request signal is input when the reset key is pressed, the backlight will be turned ON. Refer to the instruction manual issued by each machine tool builder for details. Note that whether the backlight will be turned ON when any of the machine operation board keys (other than the NC operation board keys) is pressed will differ according to the machine specifications. Refer to the instruction manual issued by each machine tool builder for details.
- (2) If a key is pressed or the screen display request signal is input while the screen is displayed, counting of the time to turn the backlight OFF will restart. However, even if [SHIFT] key is pressed, counting of the time to turn the backlight OFF will not restart.
- (3) Operation when the  or  key is pressed will differ according to the machine tool builder. Refer to the instruction manual issued by each machine tool builder for details.
- (4) When the backlight is turned ON, the first character is ignored if the [SHIFT] + [A] to [W] key is input. (Ex. WHILE -> HILE)

1.11 Screen Capture

When "1" is set to the parameter "#8121 Screen Capture", and then [SHIFT] key is kept pressing for about 3 seconds until the buzzer sounds the screen information displayed in the display unit can be output to memory card (CF) as a file of the bitmap format.

Operation method

- (1) Set the parameter "#8121 Screen Capture" to "1".
- (2) Display the screen to capture..
- (3) Hold down the [SHIFT] key on keyboard for three seconds until the buzzer sounds.  When the [SHIFT] key is pressed, the buzzer sounds "blip". About three seconds later, the bitmap file output is completed when the buzzer sounds "blip" again.
- (4) Return the parameter "#8121 Screen Capture" to "0".

Bitmap file format

The bitmap file format output by the screen-capture function is as follows.

Color number	Color (256 colors)
Size	308,278byte(640 × 480)
File name	A day of the week_Month_Day_Hour_Minute_Second_Year.bmp (Ex.)

(Ex.) When output at 2007/1/24 (Wed) 12:18:38
WED_JAN_24_12_18_38_2007.bmp

Precautions

- (1) The static image only can be output.
- (2) The bitmap file cannot be output during automatic start.
- (3) Do not output the bitmap file while the axis is moving by the manual operation mode etc.
- (4) The screen cannot be operated while the bitmap file is being output to memory card (CF). Do not turn OFF the power supply while being output. The memory card may be damaged.
- (5) The bitmap file cannot be output when the memory card is not inserted.
- (6) When there is no empty capacity in the memory card, the bitmap file cannot be correctly displayed.
- (7) The number of bitmap files which can be stored in the memory card is nine files or less.

1.12 Menu Customization Function

This function allows to change the display order of monitor, setup and edit screen.

This function enables to place the often-used keys in the first page.

It can be used when a parameter "#11032 Menu sel para lkof Validate menu selection parameter setting" is set to "2".

Machine tool builder's password is required when it is set to "1".

The main menu of monitor screen, setup screen and edit screen correspond to the following parameters.

<Menu selection parameter>

Main menu for monitor screen: "#10501 Monitr main menu 1" to "#10530 Monitr main menu 30"

Main menu for setup screen: "#10551 Setup main menu 1 to 30" to "#10580 Setup main menu 30"

Main menu for edit screen: "#10601 Edit main menu 1 to 30" to "#10630 Edit main menu 30"

Refer to "Appendix 10 User Parameters " for details.

Setting example

Main menu for monitor screen is changed as follows.

The figure below is the default layout.

<Before>

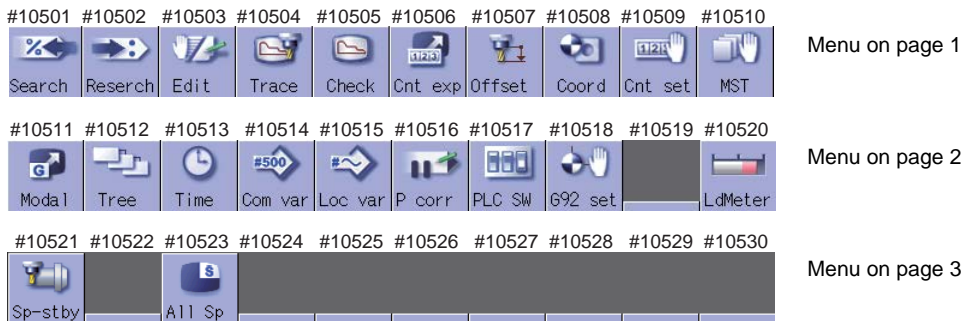

- (1) Set the parameters "#10501 Monitr main menu 1" to "#10530 Monitr main menu 30" as shown in the right.



<Parameter>	<After>
#10501	3 (Edit)
#10503	1 (Search)
#10506	11 (Modal)
#10510	-1 (Not display)
#10513	7 (Offset)
#10519	-1 (Not display)
#10525	3 (Edit)
#10527	16 (P corr)

Set "0" to the parameters other than the listed above.

- (2) Turn the power ON again



The new layout of the monitor screen's main menu will be displayed.

<After>

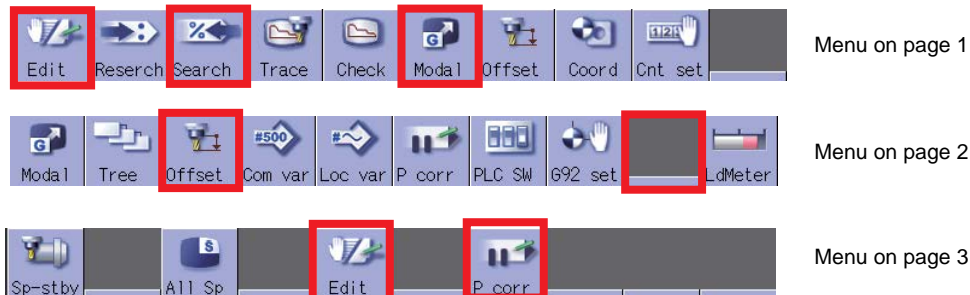

Precautions

- (1) If a menu No. for not to display the main menu is set to the menu selection parameter, it will not be displayed. Menu which is set with other menu non-display parameter (“#8923 Hide Edit-IO menu”, “#8932 Hide measure scrn”) will also not be displayed even if it is set with the menu selection parameter.
- (2) A menu selection parameter setting will be reflected to the menu list.
- (3) Menus which are allocated to the short cut key (it is enabled after the axis address is input), such as [Counter Set] and [MST], become valid by pressing a short-cut key even if they are set as "Not display".
- (4) The menu set as hidden by the machine tool builder will not appear, even if it is set by this function.



2

Monitor Screens



Various information related to operation, such as the axis counter, speed display and MSTB command are displayed on the Monitor screen. The following operations regarding operation can be executed.

- (1) Operation search
- (2) Restart search
- (3) Editing the searched machining program
- (4) Trace (Display of machine movement path)
- (5) Check (Display of NC program's tool movement path)
- (6) Correction of operating program's buffer
- (7) Counter set
- (8) Manual numeric command etc.

2.1 Screen Configuration

"Auto/MDI" and "Manual" are displayed at the upper left of the screen. These displays change according to the mode selection switch.

<For Auto/MDI>

8.4-type

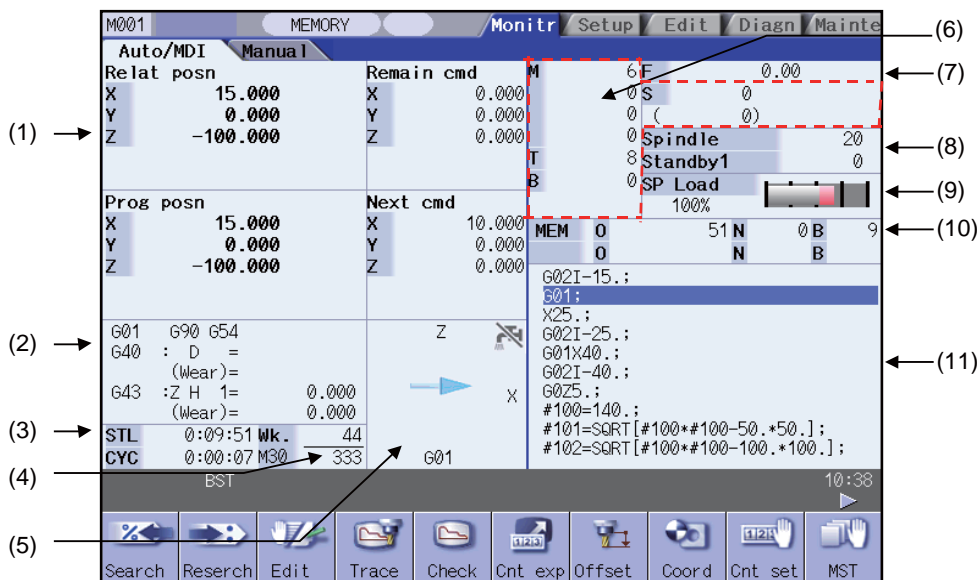

<For Manual>

8.4-type

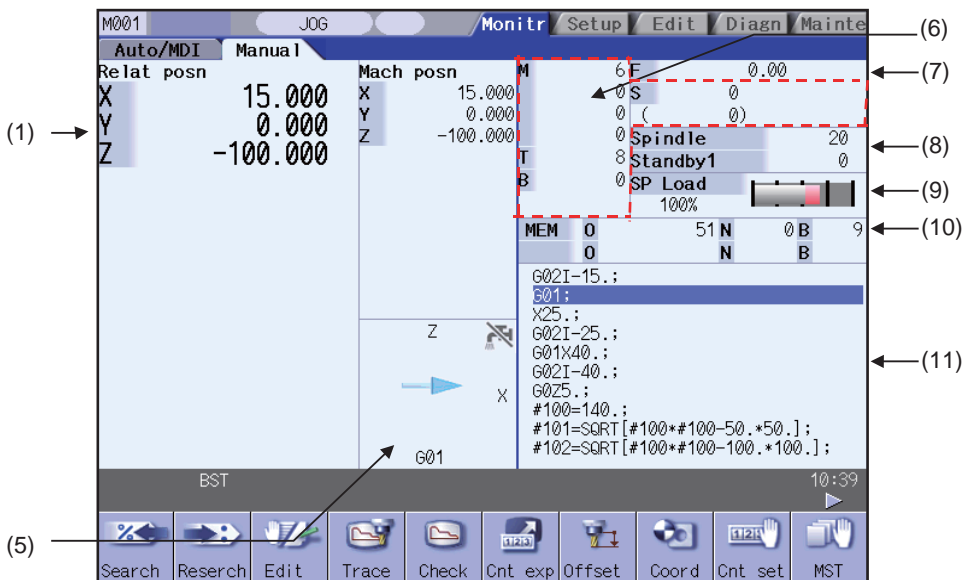













Display items









Display item	Details
(1) Counter display	<p>This displays the counter of the relative position and workpiece coordinates positions, etc. If each axis is in a specific position or status, the following status symbol appears.</p> <p>#1 to #4 : No. 1 to No. 4 reference position][: Servo OFF state MR : Mirror image >< : Axis removed state CT : Auxiliary axis state</p> <p>Whether to allow for the tool length compensation and tool radius compensation can be set with the parameter "#1287 ext23/bit4". Whether to display the axis counter can be set by the parameter "#1069 no_dsp". The layout of counter display can be changed by the parameter. (Refer to "2.1.1 Counter Display" for details.)</p>
(2) G modal simple display	<p>This displays the modal status.</p> <p>[8.4-type] G command modal status of Group 1 G command modal status of Group 3 Selected workpiece coordinate system Tool radius compensation modal, compensation No. shape compensation amount, tool radius wear amount Tool length compensation modal, compensation axis name, compensation No., shape compensation amount, tool length wear amount</p>
(3) Cycle time display	<p>This displays the automatic operation time and cycle time. The displayed items are switched with integrated time window.</p>
(4) Completed workpiece display	<p>This displays the number of workpieces which have been completed. The display follows the machining parameters "#8001 WRK COUNT M" to "#8003 WRK COUNT LIMIT".</p>
(5) Machine status animated display	<p>This displays the current tool No., tool type, next command movement direction, coordinate rotation status, mirror image status, and spindle rotation direction/coolant status. Note that the spindle rotation direction/coolant status display differ according to the machine tool builder.</p>
(6) M, S, T, B commands	<p>This displays the values command for M (miscellaneous function command value), T (tool command value), B (2nd miscellaneous function command value), S (spindle command rotation speed) and a number of workpiece machining times.</p> <p>The displayed number of M (miscellaneous function command value) depends on parameter "#12005 Mfig". The displayed number of T (tool command value) and B (2nd miscellaneous function command value) is "1" regardless of the parameters "#12009 Tfig" and "#12011 Bfig". However, the display/non-display of B (2nd miscellaneous function command value) depends on parameter "#1170 M2name". Refer to "Manual numerical value command" for the manual numerical value commands. For lathe system, parameter "#11038 T disp type (tool command value) switch" determines whether to displays tool command value only, or tool command value combined with tool No. and compensation No. This displays the S command and spindle actual rotation speed value about S (spindle command rotation speed). S command is always displayed. However the spindle rotation speed might not be displayed by screen area constraints.</p>
(7) Speed display	<p>In interpolation feed: This displays the vector direction speed currently being moved in.</p> <p>In each axis independent feed: This displays the speed of the axis with highest speed. The actual machine feedrate is displayed with the parameters "#1125 real_f".</p>
(8) Spindle/Wait display	<p>The spindle tool No. and the standby tool No. are displayed. These displayed contents differ according to the machine tool builder.</p>
(9) Load meter display	<p>The spindle load and Z axis load, etc., are displayed in a bar graph. If Spindle/standby display is not being used, a load meter can be displayed in the Spindle/standby display area. These displayed contents differ according to the machine tool builder.</p>

Display item	Details
(10) Machining program currently being executed (Note)	
Main 010	This displays the program No., sequence No. and block No. currently being executed.
Sub 01234	When a subprogram is being executed, this displays the subprogram's program No., sequence No. and block No.
(11) Buffer display	This displays the contents of the machining program currently being executed. The block being executed is highlighted. (Note)A program may not be displayed correctly if the program comment includes a character which is displayed in a two-byte width per character code.

(Note) If the program No. (program name) exceeds 12 characters, "*" will appear at the 12th character.

Menus

Menu	Details	Reference
 Search	This executes operation search.	2.2 Operation Search
 Reserch	This executes restart search.	2.3 Restart Search
 Edit	This edits the machining program in search.	2.4 Program Edit
 Trace	This executes trace.	2.5 Trace
 Check	This checks the program.	2.6 Program Check (2D)
 Cnt exp	This enlarges the counter, and displays the counters for all axes.	2.7 Counter All-axis Display
 Offset	This displays the tool compensation amount. A value can also be set for the tool compensation amount.	2.8 Tool Offset Amount
 Coord	This displays the workpiece coordinate system offset. A value can also be set for the workpiece coordinate system offset.	2.9 Workpiece Coordinate System Offset
 Cnt set	A arbitrary value can be set in the relative position counter.	2.10 Counter Set
 MST	This executes a manual numerical value command.	2.12 Manual Numerical Value Command
 Modal	This displays the program modal.	2.13Modal Display
 Tree	This displays the program tree.	2.14 Program Tree Display
 Time	This displays the date, time and integrated time, etc., The date, time and integrated time, etc., can also be set.	2.15 Integrated Time Display

Menu	Details	Reference
 Com var	This displays the common variables. A value can also be set for the common variable.	2.16 Common Variables
 Loc var	This displays the local variables.	2.17 Local Variables
 P corr	This corrects the buffer.	2.18 Buffer Correction
 PLC SW	This turns the PLC switches ON or OFF.	2.19 PLC Switch Function
 G92 set	This sets and cancels the origin.	2.11 Origin Set, Origin Cancel
 LdMeter	The spindle load and Z axis load, etc., are displayed in a bar graph. These displayed contents differ according to the machine tool builder.	2.20 Load Meter Display
 Sp-stby	The current spindle tool No. and the standby tool No. are displayed. These displayed contents differ according to the machine tool builder.	2.21 Spindle, Standby Display
 All Sp	This displays commanded/actual rot speed values of all the spindles.	2.22 All Spindles' Rotation Speed Display

2.1.1 Counter Display

The counter display contents are as follows.

(1) Auto/MDI
<8.4-type>

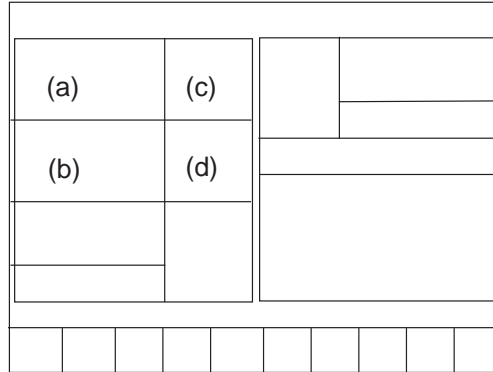

Layout	Display	Remarks
(a)	Relative position	This can be changed with "#8901 counter type 1".
(b)	Program position	This can be changed with "#8902 counter type 2".
(c)	Remaining command	This can be changed with "#8903 counter type 3".
(d)	Next command	This can be changed with "#8904 counter type 4".

(2) Manual
<8.4-type>

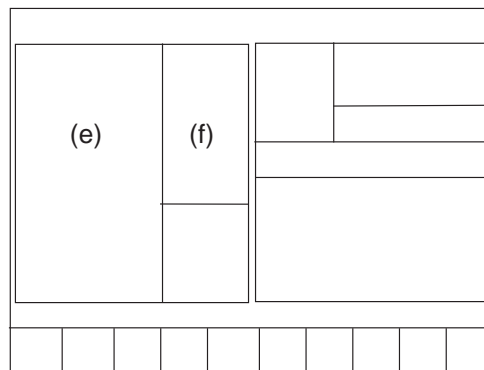

Layout	Display	Remarks
(e)	Relative position	This can be changed with "#8905 counter type 5".
(f)	Machine position	This can be changed with "#8906 counter type 6".

2.1.2 Switching the Counter Types

When Manual display or enlarged counter is selected ("#8909 Aut/Manual switch"="3"), it is possible to change counter types to display with the tab keys ([<-] / [->]).

In Manual display, with the tab keys, the counter displayed at the left (the counter set by the parameter "#8905 Counter type 5") is switched. If the counter type is changed with the tab keys, the setting of the parameter "#8905 Counter type 5") will also be changed.

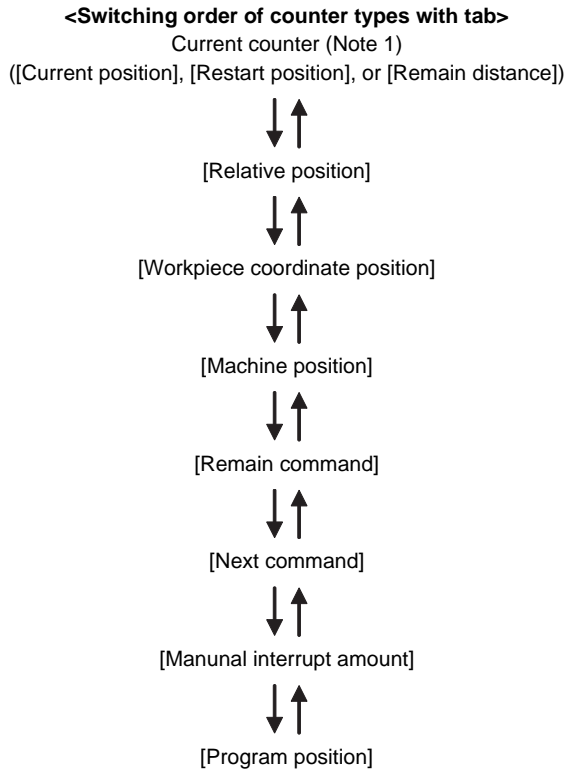

(Note 1) If the current counter type (the counter type set by "#8905 Counter type 5" before switching with the tab keys) is other than [Current position], [Restart position], or [Remain distance], those counters will not be included in the counter types switchable with the tab keys.

(Note 2) When a parameter "#8951 No Tab counter sw." is set to "1", a counter type will not be changed by the tab keys.

2.1.3 Changing Between <Auto/MDI> and <Manual>

The correspondence between the mode selection switch settings and display contents on the left side of the screen is as follows.

#8909 Aut/Manual switch	Mode selection switch setting	Screen display
0	No mode	Auto/MDI
	Memory	
	Tape	
	MDI	
	Jog	Manual
	Handle	
	Step	
	Manual arbitrary feed	
	Reference position return	
	Automatic dog-less reference position return	
	Rapid traverse	
	Jog + handle	
	Rapid traverse + handle mode	
	1(Auto/MDI)	
2(Manual)	All mode	Manual
3(enlarged)	All mode	-

(Note 1) If the parameter "#8909 Aut/Manual switch" is set to other than "0", "Auto/MDI" and "Manual" is not switched.

(Note 2) If the parameter "#8909 Aut/Manual switch" is set to "3", the counter set by "#8901Counter type 1" is enlarged.

2.2 Operation Search



On this screen, the program can be called from the program storage site, such as a memory, by designating the program (program No.) to be automatically run and the program start position (sequence No., block No.).

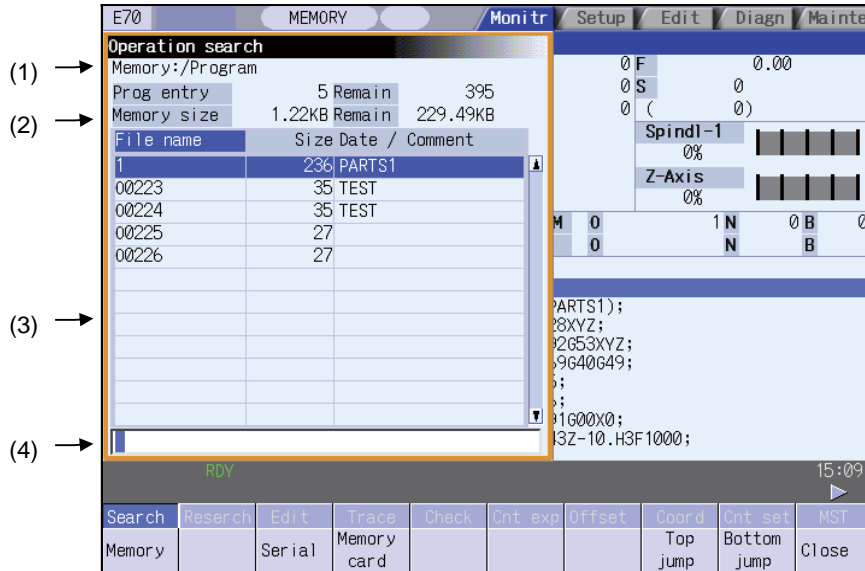

Display items

Display item	Details
(1) Device name, directory display	This displays the device name and directory designated when the program was selected.
(2) Capacity display	This displays the capacity of the device displayed in (1).
(3) List of directories and files	This displays a list of the contents contained in the device or directory displayed in (1). Use and to scroll the displayed list. If the device is a memory card, the file update date/time is displayed in the <Date/Comment> field. For the NC memory, the machining program comment is displayed. Whether to show or hide the comment field can be selected by pressing the [Comment nondisp] menu. When the comment field is hidden, the file name field will be enlarged. (Up to 13 characters can be displayed in the file name field when the comment is shown, and 32 when the comment is hidden.) If the file name exceeds the maximum number of characters, "*" will appear at the last character.
(4) Input area	This displays the input key details.

Menus

Menu	Details	Type	Reference
Memory	This selects the device for searching for the program. When a device with directory is selected, the route is selected first.	C	2.2.1 Executing an Operation Search
Serial		C	
Memory card		C	
Top jump	Display starts from the first page of the directory/list of files. The cursor moves to the top line.	C	
Bottom jump	The last page of the directory/list of files is displayed. The cursor moves to the bottom line	C	
Comment nondisp	This changes whether to show or hide the comment field in the list. When the comment field is hidden, the file name field will be enlarged.	B	2.2.2 Changing Whether to Show or Hide the Comment Field
List update	This updates the list contents. (The latest contents of the currently selected device and directory are listed.)	C	
Sort change	This changes the method that the list is sorted.	C	2.2.3 Changing the Sorting Method
Close	This closes the pop-up window and quits this function.	C	

(Note 1) Some items may not be displayed depending on the device.

○ : Displayed × : Not displayed.

Display item	Device		
	Memory	Serial	Memory card
Prog entry	○	×	○
Remain	○	×	×
Memory side	○	×	○
Remain	○	×	○
List	○	×	○

(Note 2) When using serial, the port number set with parameter "#9005 TAPE MODE PORT" is connected, and search.

2.2.1 Executing an Operation Search

Operation method

- (1) Press the main menu [Search]. ➔ The sub-menu appears.
The list appears as a pop-up window.
- (2) Select the device.
(Example) [Memory card] ➔ The selected device name and route directory (memory card) appear in the Device name, Directory display field.
- (3) Using the [↑], [↓], [←], [→] keys, move the cursor to the directory containing the file to be set. ➔ The following is displayed.



If the list contents differ from the actual device or directory, press the menu [List Update].

- (4) Press the [INPUT] key. ➔ The active window changes to the directory.

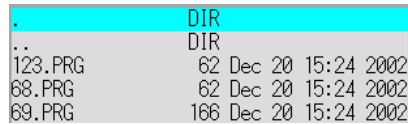

- (5) Using the [↑], [↓], [←], [→] keys, move the cursor to the target machining program.
- (6) Press the [INPUT] key. ➔ The search starts.
When the search is completed, the operation message "Search Complete" appears.
The searched device and program position appear in the field for displaying the machining program currently being executed.
The list closes, and the main menu appears again.

When designating the sequence number and block number and searching for the program, input the search conditions in the input area. The program No. is categorized according to the presence of an extension.

Input details	Program No.	Sequence No.	Block No.
1001/1/2	O1001	N1	B2
1001.PRG/1/2	O1001.PRG	N1	B2
/1/2	(Currently searched O No.)	N1	B2
1001//2	O1001	N0	B2
1001/1	O1001	N1	B0
1001	O1001	N0	B0
/1	(Currently searched O No.)	N1	B0
//2	(Currently searched O No.)	N0	B2

- (Note 1) Program after operation search
- (a) Operation search is cancelled if the following operations are carried out on the Edit screen after operation search. Execute restart search in this case.
 - If the searched program is erased.
 - If the searched sequence No. is erased.
 - If the block corresponding to the searched block No. is erased.
 - (b) Operation search cannot be executed in another block during MDI operation even if the block is stopped. Wait for MDI operation to end or reset the NC before searching.
- (Note2) A program with 33 or more file name characters cannot be searched.

2.2.2 Changing Whether to Show or Hide the Comment Field

The file name field can be extended by changing whether to show or hide the comment field.

Operation method

- | | | |
|--|---|---|
| (1) Press the menu [Comment nondisp]. | ➔ | The file name is displayed up to 32 alphanumeric characters and symbols after the comment field disappears. The menu is highlighted. |
| (2) Press the highlighted [Comment nondisp] again. | ➔ | The comment field appears, and the file name is displayed up to 15 alphanumeric characters and symbols. The menu highlight returns to normal. |

(Example) When the file name is "123456789A123456789B123456789C12"

"Comment display" is validated: The file name display is omitted and "*" is attached.

File name	Size	Date / Comment
123456789A12*	126	COLOR_CHK_01

"Comment display" is invalidated: The file name is displayed up to 32 alphanumeric characters and symbols.

File name	Size
123456789A123456789B123456789C12	126

(Note 1) The set status is held even if the NC power is turned OFF.

(Note 2) The set status is common for list view of operation screen, restart search screen, etc.

(Note 3) The cursor moves to the head when display/non-display in the comment field is switched.

2.2.3 Changing the Sorting Method

Sorting method changes to 1 → 2 → 3 → 4 → 5 → 1.....every time the [Sort change] menu is pressed.

The selected sorting method is also displayed in the list on the ther screens. The method is common for all the devices, as well. The sorting method will be held even after the power is turned OFF and ON.

Up to 64 files (Including current directory "." and one directory above "..") can be sorted within a directory. If exceeds 65 files, the [Sort change] menu is displayed in gray and changing the sorting method is impossible. In this case, NC memory program is displayed with "1. File name No. ascending order". Other devices are displayed with "2. File name character code ascending order".

No.	Sorting method	Priority
1	File name No. ascending order	1. "." for current directory, ".." for one directory above 2. Numerical value (excluding the case where "0" is put at the beginning) ascending order 3. Character code ascending order
2	File name character code ascending order	1. "." for current directory, ".." for one directory above 2. Character code ascending order
3	File name character code descending order	1. Character code descending order 2. "." for current directory, ".." for one directory above
4	Comment ascending order	"Date/comment" character code ascending order
5	Comment descending order	"Date/comment" character code descending order

(Note 1) The character code ascending (descending) order is the method in which file names are compared one by one using the ASCII code.

Example: If the ascending order is applied, the appropriate order would be 1 A as "1" equals to "0x31" and "A" equals to "0x41".

(Note 2) When the device is "Memory", display for "current directory" and "one directory above" is not available.

(Note 3) When comments are the same, sorting is carried out by the file name character code ascending (descending) order.

(Note 4) "Date/comment" for the devices other than "Memory" are compared using character string only. Thus, the order will not be one by the actual date.



2.3 Restart Search

If machining is temporarily stopped due to tool breakage, etc., the program restart function searches for the block of the machining program to be restarted, and restarts machining from that block.

There are two types of restart, type 1 and type 2.

Restart method	Details	
Restart type 1	After machining is reset due to a tool breakage, etc., machining is restarted from the designated sequence number and/or block number. Only the program which had been executed just before can be restarted. Even after the power is turned ON again, the program can be restarted if the program has been executed before the power supply is turned OFF. (Note 1) In case that NC has been reset or the power supply has been turned OFF while fixed cycle, custom fixed cycle, machine tool builder macro, or macro interruption is executed, the search with no input to the setting will be performed for each source program. (Note 2) When the user macro is executed, the user macro execution position is searched.	
Restart type 2	Automatic top search OFF	A top search must be executed from the screen. Then, command a sequence No. and block No., and restart a program.
	Automatic top search ON	A top search may not be executed from the screen. A top search is automatically executed, so it is not necessary to execute a top search from the screen. Command a sequence No. and block No., and restart a machining. An arbitrary program can be restarted by designating the program No. When a program No. is omitted, the program currently searched is restarted.

The validity of the automatic top search can be changed with control parameter "#8914 Auto Top search".

Screen transition

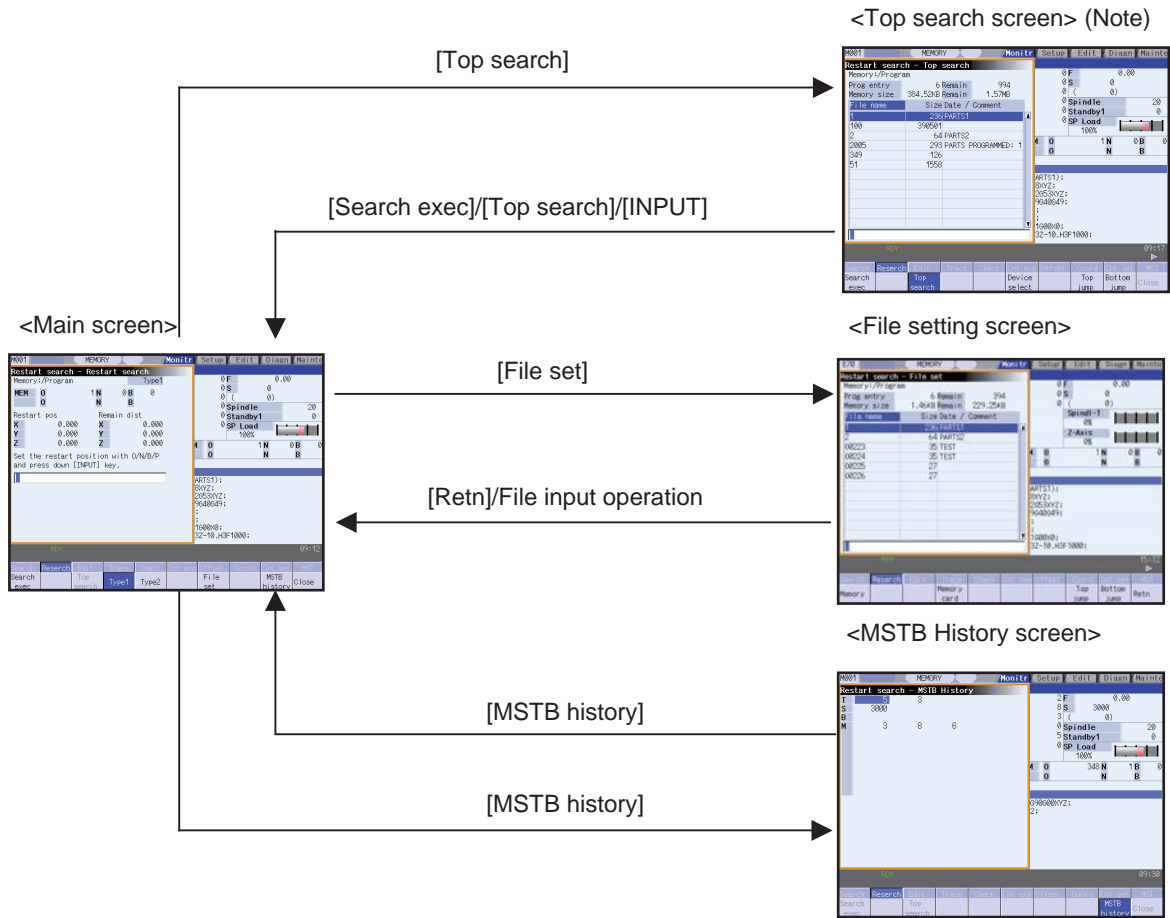

(Note) In the following cases, the screen cannot be switched to top search screen.

- Restart type 1
- The parameter "#8914 Auto Top search" is "1" (automatic top operation)

Precautions

- (1) Set the tool offset amounts and parameters before proceeding the program restart search. If they are not set beforehand, the axes will not return to the proper machining start position.
- (2) Attempting the automatic start up during the restart search causes "T01 Cycle start prohibit 0111" and it will not start up automatically.
- (3) The axes will not return to the proper machining start position if a program using the user macro external signal input, machine coordinate readout or external mirror image command executes the restart search.
- (4) If an attempt was made to shift the coordinate systems by manual or MDI interrupt the last time the machining program was being executed, the axes will not return to the position where the coordinate system was shifted whether it restarts with type 1 or type 2.
- (5) When using the type 1, a top search for the head of the program is not available.
Restart search of the type 1 searches from the previous operation start block and locates the designated block as it memorizes the operation start block previously operated.
- (6) When "#8914 Auto Top search" is set to "0" for the type 2, an error message "Top search not completed" will be displayed if the search is attempted directly with the type 2 without executing the top search.
Conduct the top search first.
- (7) The macro statement blocks cannot be searched .
It is possible to execute the restart search if the control parameter "#8101 MACRO SINGLE" is set to ON.
However, note that the tool path may change because of the radius compensation, the corner R/C, and geometric read ahead blocks.
- (8) When executing the restart for the type 1 with a tape, the axes will not return to the proper machining start position if the operation starts from midway of the tape.
- (9) WHILE/GOTO statement cannot be used for a tape operation. Thus, if a restart search is executed with the tape operation which includes WHILE/GOTO statement, a program error (P295) will occur.
- (10) A search error will occur if an intended ONB is not found even M99 block is detected in the main program.
- (11) A error will occur if the M99 block in the main program is searched.
- (12) When "#1122 pglk_c (Program display lock C)" is set to "2", the restart search cannot be executed as "Program display lock C" is applied.
- (13) If both N and B are omitted, it will be assumed as the head of the program and the number of repetitions is considered as "1" even the P number is designated.
- (14) When either N or B is omitted, the omitted one is assumed as "0".
- (15) When you execute the restart search to a block in synchronous tapping cycle modal, issue the S code for a tapping spindle from MSTB history menu. If it is not issued, the tapping spindle will execute the synchronous tapping with current gear step without changing the gear.

2.3.1 Main Screen

The type 1 and type 2 restart search can be executed from the Main screen.

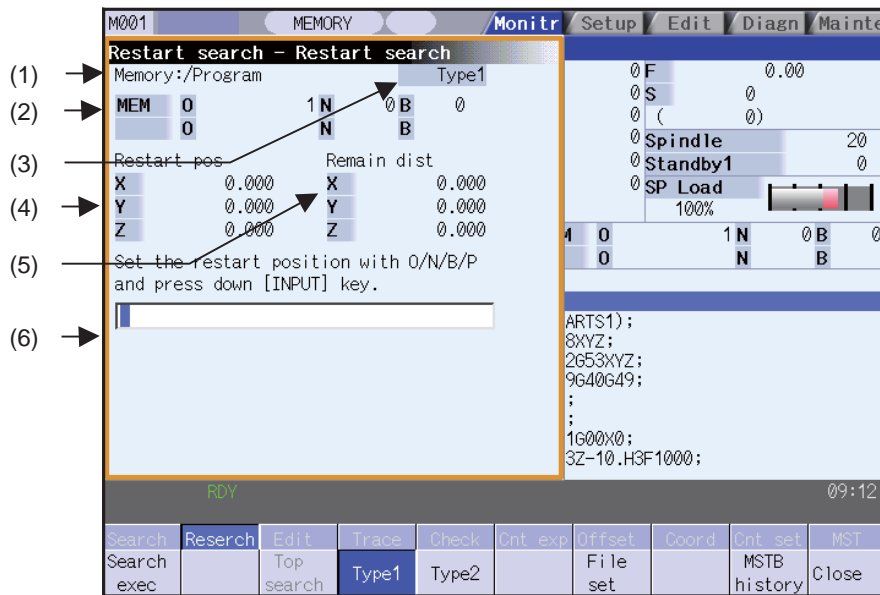

Display items

Display item	Details
(1) Device and directory display	This displays the device and directory where the searched machining program is located.
(2) Research position	This displays the researched main program position (program No., sequence No., block No.).
(3) Restart type	This displays the restart search type.
(4) Position when restart search is completed	This displays the position on the local coordinate system when the restart search is completed.
(5) Remaining distance when restart search is completed	This displays the remaining distance when the restart search is completed.
(6) Input area	This displays the input key details.

Menus

Menu	Details	Type	Reference
Search exec	This starts the restart search based on the designated device, directory, program number (O), sequence number (N), block number (B) and number of block execution times (P).	C	
Top search	This changes to the pop-up window for executing top search, and enables top search. When the type 1 is selected or the parameter "#8914 Auto Top search" is set, this menu cannot be selected.	B	2.3.2 Top Search Screen
Type1	This selects the restart search type. Restart search is executed with the highlighted restart type. The type 1 or type 2 menu is always highlighted.	B	
Type2	When restart search is executed, the selected restart type is displayed at the display item "(3) Restart type".		
File set	This changes to the pop-up window for setting the file, and enables the file to be selected.	B	2.3.3 File Setting Screen
MSTB history	This opens the MSTB history screen as a pop-up window. The M, S, T and B command used in the machining program are listed on the MSTB history screen. If the cursor is moved to the listed M, S, T or B command and the [INPUT] key is pressed, that command will be executed.	B	2.3.4 MSTB History Screen
Close	This closes the pop-up window and quits this function.	C	

2.3.2 Top Search Screen

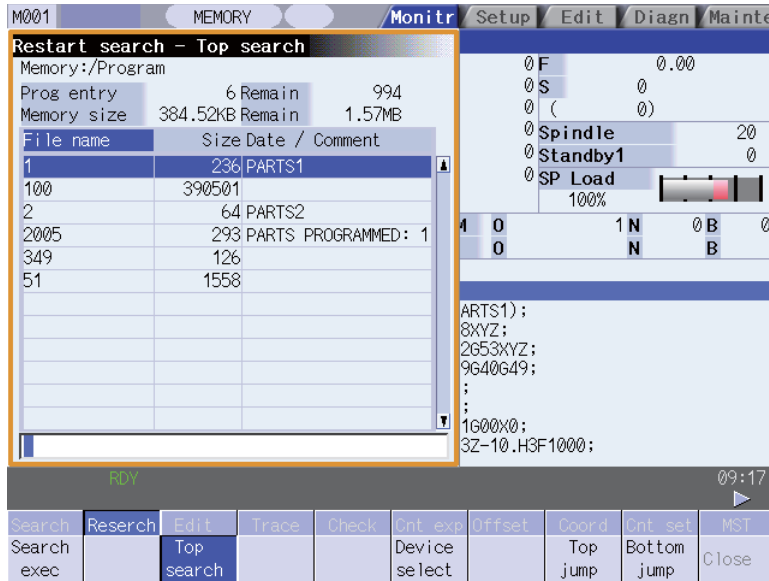

Display items

Same as "2.2 Operation Search".

Menus

Menu	Details	Type	Reference
Search exec	This starts the restart search based on the designated device, directory, program number (O), sequence number (N), block number (B) and number of block execution times (P).	C	
Top search	When the menu is highlighted, it indicates that the top search pop-up window is open. When this is highlighted, it indicates that the top search pop-up window is open. If pressed again when highlighted, the top search pop-up window closes, and the main pop-up window opens.	B	
Device select	This displays the device menu. Select which device program to search for from this menu. If a device having a directory is selected, the root is selected first.	C	
Top jump	Display starts from the first page of the directory/list of files. The cursor moves to the top line.	C	
Bottom jump	The last page of the directory/list of files is displayed. The cursor moves to the bottom line.	C	
List update	This updates the list details. (A list of the latest details of the currently selected device and directory is displayed.)	C	
Sort change	This updates the list sorting method.	C	2.2.3 Changing the Sorting Method
Comment nondisp	This changes whether to show or hide the comment field in the list. When the comment field is hidden, the file name field will be enlarged.	B	2.2.2 Changing Whether to Show or Hide the Comment Field

2.3.3 File Setting Screen

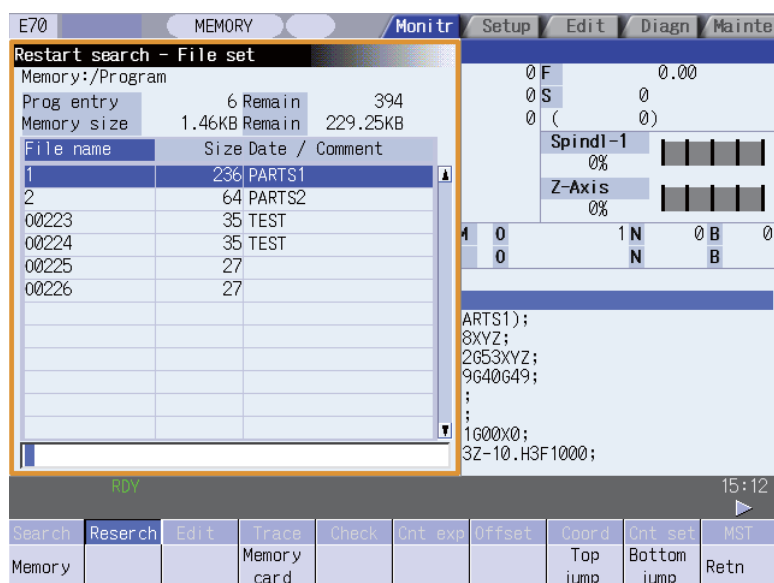
**Display items**

Same as "2.2 Operation Search".

Menus

Menu	Details	Type	Reference
Memory	Select the device to search program.	C	
Memory card	When a device other than memory is selected, the root is selected first.	C	
Top jump	Display starts from the first page of the directory/list of files. The cursor moves to the top line.	C	
Bottom jump	The last page of the directory/list of files is displayed. The cursor moves to the bottom line.	C	
List update	This updates the list details. (A list of the latest details of the currently selected device and directory is displayed.)	C	
Sort change	This updates the list sorting method.	C	2.2.3 Changing the Sorting Method
Retn	This returns the main menu.	C	
Comment nondisp	This changes whether to show or hide the comment field in the list. When the comment field is hidden, the file name field will be enlarged.	B	2.2.2 Changing Whether to Show or Hide the Comment Field

2.3.4 MSTB History Screen

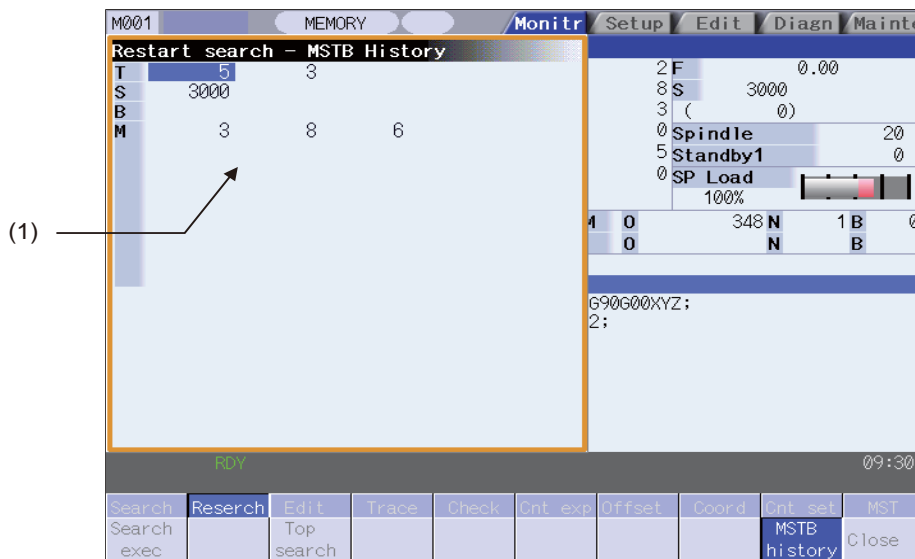

Display items

Display item	Details
(1) MSTB history	The M, S, T and B command used in the machining program are listed. Up to 35 M commands, 3 commands each for S1 to S6, 3 T commands and 3 B commands are displayed. Regardless of parameter setting value (#11038 T disp type), the display of T disp shows only tool command value.

Menus

Menu	Details	Type	Reference
MSTB history	When this is highlighted, it indicates that the MSTB history pop-up window is open. If the menu is pressed when this menu is highlighted, the system will close the MSTB history pop-up window, and the main pop-up window opens.	B	

2.3.5 Operation Sequence for Program Restart

There are two types of restart, type 1 and type 2.

Restart type 1

When feed hold has been applied and reset because the tool has broken, etc., restart with Restart type 1.

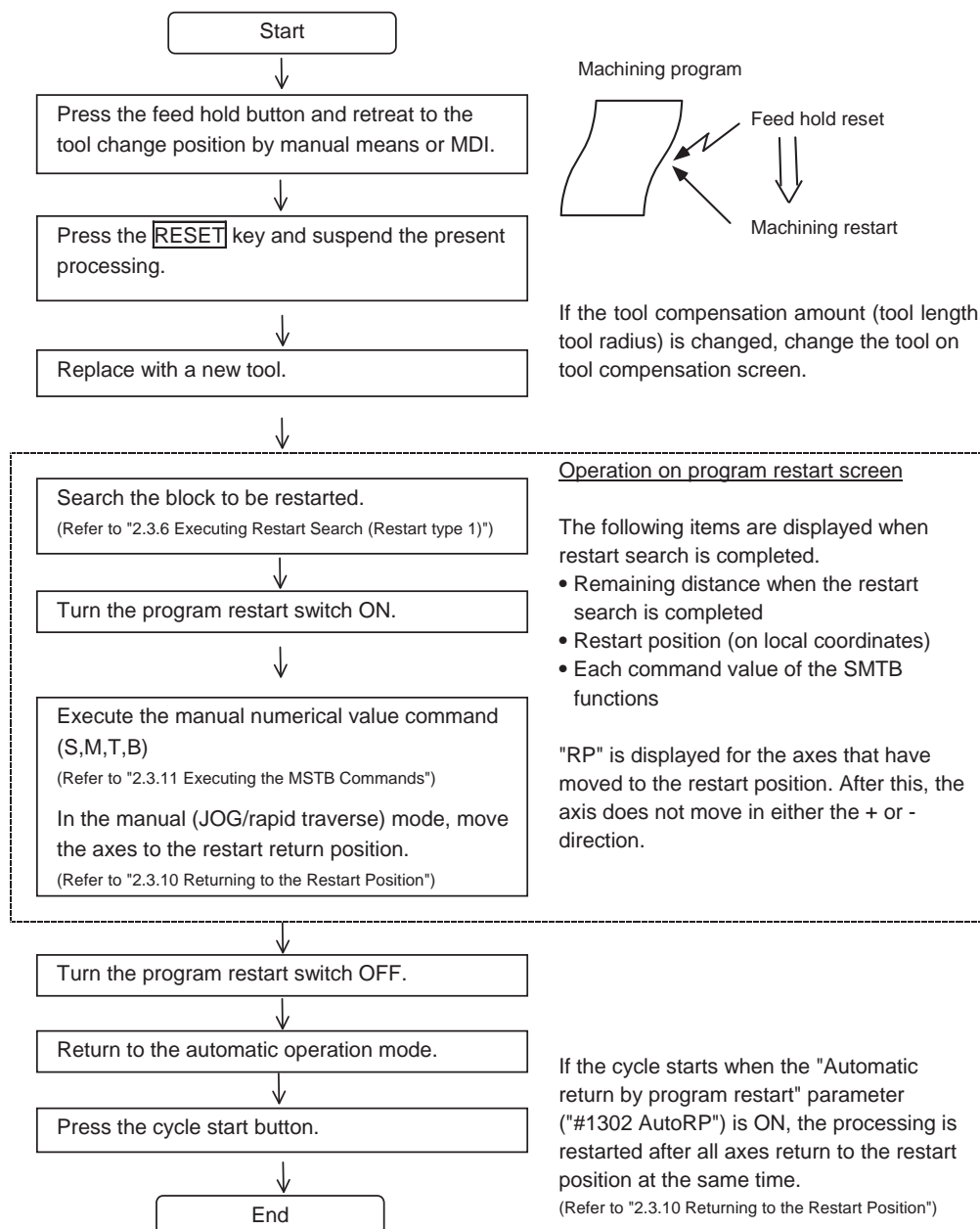

(Note 1) When single block signal is OFF, the machining is restarted without stopping temporarily after the axes return to the restart position. (The cycle starts when the automatic return by program restart is valid.)

(Note 2) Execute Reset & Rewind for resetting.

(Note 3) Restart & Search must be carried out with Restart Type 2 when the power has been turned ON again.

If Restart Type 1 is selected, "Search error" occurs.

(Note 4) Restart Search is not possible for a program with 33 or more file name characters.

Restart type 2

If a machining program differing from the machining program to be restarted was run before starting restart search, restart with restart type 2.

When the coordinate system of the automatic operation last time and the coordinate system of the machining restart are changed, it is possible to restart.

(Note) The necessary matters for starting the machining program, such as setting the coordinate system, must be completed before starting restart search.

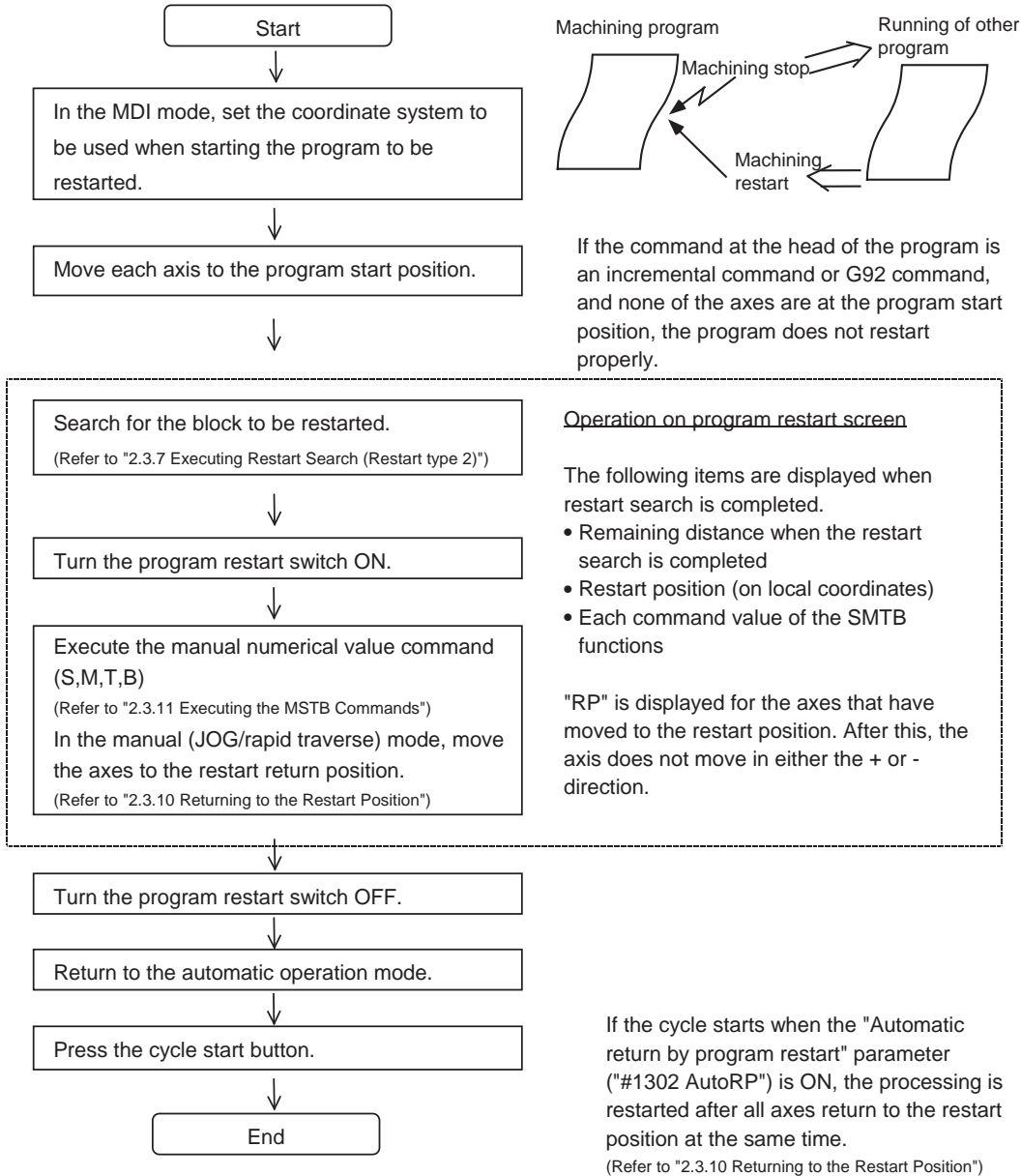

(Note 1) When single block signal is OFF, the machining is restarted without stopping temporarily after the axes return to the restart position. (The cycle starts when the automatic return by program restart is valid.)

(Note 2) Restart Search is not possible for a program with 33 or more file name characters.



(Note 3) When the searched program do not exist, the operation message "Search error" appears.

2.3.6 Executing Restart Search (Restart Type 1)

When feed hold has been applied and reset because the tool has broken, etc., restart with Restart type 1.

Operation method

(Example) When tool breakage during execution of O1000 N7 occurred, and restarting from the O1000 N6 block

- (1) Press the feed hold button and retreat to the tool change position by manual means or MDI.
Press the reset key and suspend the present processing.
- (2) Replace with a new tool.
- (3) When using tape operation, index the top of the tape.
- (4) Press the main menu [Resrart].  The submenu appears.
The main screen for restart search appears as a pop-up window.
- (5) Set the position to restart search in the setting area.  Delimit the ONB number in the setting area using /.
<When O No. was attached>
The main or sub program is targeted.
(Ex.) 1000/6/0
<When O No. was not attached>
The program currently searched is targeted.
(Ex.) /6/0
(Note) When the [INPUT] key is pressed without entering data in the input area, restart search will be carried out for the last execution block. (Type 1 only)
- (6) Press the [INPUT] or [Search exec] menu.  Restart search is executed.
The message "In restart search" appears during the search process, and the message "Restart search complete" appears when completed.
Each axis' restart position and the restart remaining distance are displayed.
When the [MSTB history] menu is pressed, the MSTB history screen will open as a pop-up window, and the M, S, T, B command used in the machining program will be listed.

2.3.7 Executing Restart Search (Restart Type 2)

If a machining program differing from the machining program to be restarted was run with tape, memory or HD operation before starting restart search, restart the respective machining program with restart type 2.

The restart type 2 operation sequence is the same as restart type 1, but necessary matters for starting the machining program, such as setting the coordinate system, must be completed before starting restart search.

When the parameter "#8914 Auto Top search" is "0", execute the top search for the machining program.







Operation method (When the parameter "#8914 Auto Top search" is "0")

(Example) When restarting from subprogram O123 N6 B2 called from main program O1000

- (1) Turn the power ON, and return all axes to the reference position.
- (2) In the MDI mode, set the coordinate system to be used when starting the program to be restarted.
- (3) Move each axis to the program restart position.
- (4) When using tape operation, index the top of the tape.
- (5) Press the main menu [Restart search]. ➡ The submenu appears. The main screen for restart search appears as a pop-up window.
- (6) Press the [Type 2].
- (7) Press the sub-menu [Top search]. ➡ The window for top search appears as a pop-up window.
- (8) Using the [↑], [↓], [↑] and [↓] keys, move the cursor to the target machining program. ➡ Set the cursor to 1000.
- (9) Press the [INPUT] key. ➡ The top search starts.
 The search can be executed by pressing the menu [Search exec] instead of the [INPUT] key. When the top search is completed, the operation message "Search Complete" appears. The top search pop-up window closes, and the main screen for restart search appears as a pop-up window.
- (10) Set the position to restart search in the setting area. ➡ Delimit the ONBP number in the setting area using /.
<When O No. was attached>
 The restart search is executed at designated position by NBP No. with the set O No. at the head.
 (Ex.) 123.PRG/6/2/1
 <When O No. was not attached>
 The program currently searched is targeted.
 (Ex.) /6/2/1
 P sets the number of times that the block targeted for the restart search appears.
 For example, if a block in a subprogram is searched, and the subprogram is called out several times, the block to be searched is also executed several times. Thus, which execution block to be searched must be set. (If "0" is set, it is handled in the same manner as "1".)
 To search the first execution block, or to search for a block executed only once, this item does not need to be set.
- (11) Press the [INPUT] or [Search exec] menu. ➡ Restart search is executed.
The message "In restart search" appears during the search process, and the message "Restart search complete" appears when completed.
 Each axis' restart position and the restart remaining distance are displayed.
 When the [MSTB history] menu is pressed, the MSTB history screen will open as a pop-up window, and the M, S, T, B command used in the machining program will be listed.

Operation method (When the parameter "#8914 Auto Top search" is "1")

(Example) When restarting from subprogram O123 N6 B2 called from main program O1000

- (1) Turn the power ON, and return all axes to the reference position.
- (2) In the MDI mode, set the coordinate system to be used when starting the program to be restarted.
- (3) Move each axis to the program restart position.
- (4) When using tape operation, index the top of the tape.
- (5) Press the main menu [Restart search].  The submenu appears.
The main screen for restart search appears as a pop-up window.
- (6) Press the [Type 2].
- (7) Press the sub-menu [File set].  The window for file set appears as a pop-up window.
- (8) Using the [↑], [↓], [↑] and [↓] keys, move the cursor to the target machining program.  Set the cursor to 1000.
- (9) Press the [INPUT] key.  The screen for restart search appears as a pop-up window.
- (10) Set the position to restart search in the setting area.  Delimit the ONBP number in the setting area using /.
<When O No. was attached>
The restart search is executed at designated position by NBP No. with the set O No. at the head.
(Ex.) 123.PRG/6/2/1
<When O No. was not attached>
The program currently searched is targeted.
(Ex.) /6/2/1
- (11) Press the [INPUT] or [Search exec]  Restart search is executed.
The message "In restart search" appears during the search process, and the message "Restart search complete" appears when completed.
Each axis' restart position and the restart remaining distance are displayed.
When the [MSTB history] menu is pressed, the MSTB history screen will open as a pop-up window, and the M, S, T, B command used in the machining program will be listed.

2.3.8 Changing the Device**Operation method**

- (1) Press the submenu [File set].  The window for file setting appears as a pop-up window.
- (2) Select the device, and press the menu key.  The selected device name and root directory appear in the Device name and Directory display field.

2.3.9 Changing the Directory with the Main Screen

Operation method

(1) Press the submenu [File set]. ➡ The window for file setting appears as a pop-up window.

(2) Using the [↑], [↓], [←] and [→] keys, move the cursor to the directory to be moved. ➡ The following is displayed.

.	DIR
..	DIR
ABC	DIR
SRAM.BIN	1019904 Mar 06 14:54 2003

If the list contents differ from the actual device or directory, press the menu [List Update].

(3) Press the [INPUT] key. ➡ The directory changes, and the contents of the designated directory appear in the list. The moved directory appears in the directory display field.

.	DIR
..	DIR
123.PRG	62 Dec 20 15:24 2002
88.PRG	62 Dec 20 15:24 2002
89.PRG	166 Dec 20 15:24 2002

(4) Repeat steps (2) and (3).

(5) After changing the directory, press the [Retn] or [CANCEL] key. ➡ The restart search main window opens as a pop-up window.

2.3.10 Returning to the Restart Position

The axis is returned to the restart position after restart search is completed.

The method for returning to the restart position (manual/automatic) can be selected with the parameters "#1302 AutoRP".

- 0 : Manual restart position return
- 1 : Automatic restart position return

Operation method (manual restart position return)

- (1) Turn the restart switch ON.
- (2) Enter the manual (JOG/rapid traverse) mode.
- (3) Move the axis in the restart return direction.

➡ The restart position and "RP" appear sequentially from the axes that have been returned. The Restart remaining distance is "0".

Restart pos	Remain dist
X1 40.000	X1 40.000
Y1 150.100	Y1 150.100
Z1 -70.000	Z1 -25.000

(4) When all axes have been returned, turn the restart switch OFF.

- (Note 1) When the restart switch is ON, move the axis in the same direction as the restart direction. If moved in the reverse direction, the operation error "M01 R-pnt direction illegal" occurs. If the tool needs to be retracted once, such as if the tool is interfering with the workpiece, turn the restart switch OFF and retract the axis manually.
- (Note 2) After restart position return is completed, the axis cannot be moved if the restart switch is ON. If the axis is moved, the operation error "M01 restart switch ON" occurs.
- (Note 3) If even one axis has not completed return to the restart position at cycle start, the error "T01 Restart pos. return incomplete" occurs. Note that if the axis has been returned to the restart position once and is not at the restart position during cycle start, the alarm does not occur.
- (Note 4) If the axis to be returned to the restart position is a machine lock axis, the operation error "M01 program restart machine lock" occurs. Release the machine lock before returning to the restart position.
- (Note 5) If the restart switch is turned to ON after the axis is returned to the restart position with the restart switch OFF, "PR" may not be displayed. Return to the restart position after the restart switch is turned ON.
- (Note 6) After restart search had been completed, if the movement command is issued by MDI before automatic restart position return has been started, the program error (P48) occurs. Perform the operation again after reset.
- (Note 7) After restart search had been completed, if the T command different from the program is issued by MDI before the searched program has been started, the program error (P48) may occur. Perform the operation again after reset. T commands which result in errors are shown below. (Only L system)
- (1) When "#1100 Tmove" = "0"
T command that selects a tool with different tool length/wear amount than the tool selected by the program
 - (2) When "#1100 Tmove" = "1"
A program error will not occur by T command.
 - (3) When "#1100 Tmove" = "2"
T command that selects a tool with different wear amount than the tool selected by the program
- (Note 8) After restart search had been completed, if the handle interruption is performed before the searched program has been started, always the same operation as manual absolute ON is executed regardless of "Manual absolute" signal.

Automatic restart position return

If the parameter "#1302 AutoRP" is set to "1", each axis returns to the restart position with dry run at cycle start. Machining restarts after returning. The order that the axes return follows parameter "#2082 a_rstax".

- (Note 1) Manually move the axis to a position where the tool does not interfere with the workpiece before starting the cycle.
- (Note 2) Even if the parameter "#1302 AutoRP" is set to 1, the axes can be returned manually to the restart position by turning the restart switch ON. In this case, move the axes in the order of manual restart position return → automatic restart position return. After completing automatic restart position return, if the operation is stopped temporarily and the restart switch is turned ON, the operation error "M01 restart switch ON" occurs.
- (Note 3) Once the axis has been manually returned to the restart position, if it is moved from the restart position, it will not return to the restart position even if automatic restart position return is executed.
- (Note 4) The axis for which parameter "#2082 a_rstax" is set to 0 does not return to the restart position. Note that if 0 is set for all axes, all axes simultaneously return to the restart position. If the axis for which parameter "#2082 a_rstax" is set to 0 has not completed manual restart position return when automatic restart position return is started, the error "T01 Restart pos. return incomplete" occurs.
- (Note 5) After automatic restart position return had been started, if the automatic start is executed during MDI mode before not all axes have yet to complete automatic restart position return, the error "T01 Restart pos. return incomplete" occurs.
- (Note 6) After restart search had been completed, if the movement command is issued by MDI before automatic restart position return has been started, the program error (P48) occurs. Perform the operation again after reset.
- (Note 7) After restart search had been completed, if the T command different from the program is issued by MDI before the searched program has been started, the program error (P48) may occur. Perform the operation again after reset. T commands which result in errors are shown below. (Only L system)
- (1) When "#1100 Tmove" = "0"
T command that selects a tool with different tool length/wear amount than the tool selected by the program
 - (2) When "#1100 Tmove" = "1"
A program error will not occur by T command.
 - (3) When "#1100 Tmove" = "2"
T command that selects a tool with different wear amount than the tool selected by the program
- (Note 8) After restart search had been completed, if the handle interruption is performed before the searched program has been started, always the same operation as manual absolute ON is executed regardless of "Manual absolute" signal. When manual interruption is executed to the automatic restart position return completed axis, the axis never returns the automatic restart position again.
- (Note 9) When an axis moved to return is operated manually, the axis cannot return to correct position.



2.3.11 Executing the MSTB Commands

If the MSTB history menu is pressed after restart search is completed, the MSTB commands used for machining program appear.

When the cursor is moved to the listed M, S, T, B commands and the [INPUT] key is pressed, that command will be executed.

Up to 35 M commands, 3 commands each for S1 to S6, 3 T commands and 3 B commands are displayed. If many MSTB commands are used for machining, the MSTB commands used at first will not appear.

Operation method

- | | | |
|---|---|--|
| (1) Press the submenu [MSTB history]. |  | The pop-up window changes to the MSTB history window. The MSTB commands used for machining program are listed. |
| (2) Using the [↑], [↓], [→] and [←] keys, move the cursor to the position of the data to set. | | |
| (3) Press the [INPUT] key. |  | The designated command is executed. A value, which has been commanded once, is displayed in gray. The cursor will move to the next item. |
| (4) Repeat steps (2) and (3). | | |
| (5) When completed with all settings, press the [Close] or [MSTB history] menu. |  | The MSTB history pop-up window closes and the restart search main window appears as a pop-up window. |

2.4 Program Edit



The machining programs are edited. When the main menu [Edit] is pressed, or turn ON the "Edit/Search" signal, the operation searched program (MDI program for MDI mode) appears.

If no program has been searched or tape operation has been executed, the edit window will not open.

When the program is edited, the key input data is directly written into the program display area. All data is overwritten from the cursor position. "Editing" appears on the right side of the file name display when the input starts.

When the [INPUT] key is pressed, the program is saved in the NC memory and the "Editing" message disappears.

Refer to "4.2 Program Edit" for details.

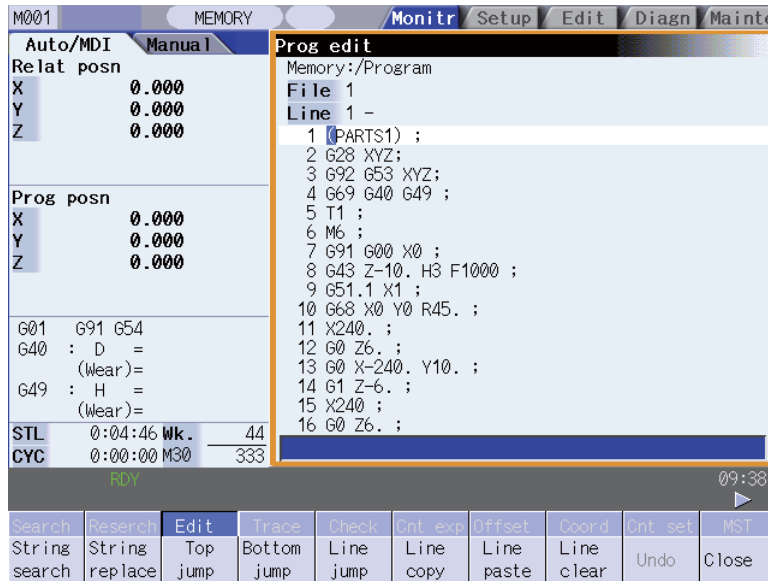

2.4.1 Edit/Search window

By turning ON/OFF the edit/search signal, the operation search is carried out starting from the block that has the cursor. There are 2 ways to implement cursor position search: "INPUT search" and "Edit/Search signal search". When the status is automatic operation, checking, or restart search, cursor position search cannot be operated. If parameter "#11039 Curs pos srch type" is set to "1", however, cursor position search can be operated even during single block stop. Refer to "Operation method (search during single block stop)" for details.

Operation method (INPUT Search)

By pressing [INPUT] key when it is in the normal status (not being in status such as editing or character searching, etc.), operation search of the selected part system is carried out starting from the block that has the cursor.

It is valid if "1" is set to parameter "#11031 Cursor pos search".

- (1) Carry out the operation search to find the program to carry out the cursor position search.

- (2) Press the [Edit].



The edit/search window is displayed. The program is displayed starting from the block currently searched. (During automatic operation or checking, the program is displayed from its top.)

- (3) Move the cursor to the block to carry out the cursor position search.

- (4) Press [INPUT] key.



The operation search is carried out starting from the block that has the cursor.

"Searching" is displayed in flickering during the search. When the search is completed, "Search completed" is displayed.

(Note 1) When operating character string search, string replace, cursor on input unit, or editing it will not start cursor position search by pressing [INPUT] key.

(Note 2) Operating search program will be the program that was searched when program edit window was open.

(Note 3) When MDI program is displayed, the block with the cursor will be set for MDI by pressing [INPUT] key.

(Note 4) If the [INPUT] key is pressed when data protect key 3 is valid, cursor position search will be executed without displaying "data protect" message. "Search completed" message appears upon completion.

Operation method(Edit/Search signal search)

It is valid if "2" or "3" is set to parameter "#11031 Cursor pos search".

- (1) Carry out the operation search to find the program to carry out the cursor position search.
- (2) Turn ON the edit/search signal.



The edit/search window is displayed.

The program is displayed starting from the block currently searched.

(During automatic operation or checking, the program is displayed from its top.)

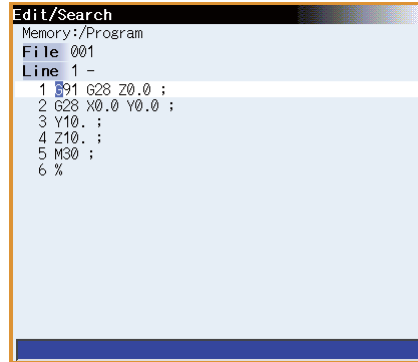

- (3) Move the cursor to the block to carry out the cursor position search.
- (4) Turn OFF the edit/search signal.



The edit/search window is closed, and the operation search is carried out starting from the block that has the cursor.

When the search is completed, "Search completed" is displayed.

(Also in the case where the screen is changed with a function key, etc. and the edit/search window is closed, the operation search is carried out.)

- (Note 1) The edit/search window is displayed only on the monitor screens. However, even on the monitor screens, if a window other than the program edit window (operation search window, menu list, guidance, etc.) is displayed, the edit/search window will not be displayed.
- (Note 2) If the edit/search window is attempted to be closed during editing, a message to confirm whether to save the data will appear.
When it appears, if save is carried out by pressing the [Y] or [INPUT] key, the operation search will be carried out starting from the block that has the cursor.
If save is not carried out, the edited data will be aborted, and the operation search will not be carried out.
- (Note 3) In the following cases, edit/search is not available with the edit/search window.
 - Edit lock B, C is enabled
 - Operation search is not carried out
 - Edit file size exceeded
 - A serial program is being searched

Operation method (search during single block stop)

Cursor position search can be operated during single block stop when parameter "#11039 Cusr pos srch Tyoe" is "1". By pressing [Edit] menu during single block stop, single block stop position becomes top of the program display.

- (1) Pause automatic operation with single block stop.

The "Prog edit" window appears. The block where the operation is stopped due to single block stop is displayed on the top.

- (2) Press the [Edit].



Be noted, though, that when implementing mass-editing, the block where cursor is positioned will not always be displayed on the top if the program length is 16 lines or less or if the cursor is at the last or first block of the program. In these cases, the first or the last block of the program comes to the top of the display.

If the operation has been stopped in a subprogram, that subprogram is displayed.

- (3) Move the cursor to the block to carry out the cursor position search.

- (4) Press [INPUT] key.



The search will operate by single block stop position with top. During the search "Searing" will display blinking. When the search is completed, "Search completed" is displayed.

(Note 1) Blocks lower than the point of the single block stop only are eligible for cursor position search designation during single block stop. "Search error" will display and the search will fail when cursor position search is attempted at an already executed block.

(Note 2) The blocks between single block stop position and search position block will be ignored when cycle start is operated after cursor position search is operated during single block stop.

(Note 3) If cursor position search is commanded at a block that causes a program error, the block of the single block stop, instead of the cursor position search target block, will appear on the top of program buffer display upon automatic start up.

(Note 4) If cursor position search is commanded at a block that comes later than a fixed cycle while stopped with single block stop in the midst of the fixed cycle, the cursor position search target block will appear on the top of the program buffer display. However, automatic operation will start from the top of the remaining of the fixed program, and after finishing the fixed cycle, will move on to executing the cursor search target program.

2.5 Trace

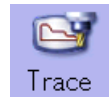

This function illustrates the actual machine's movement path or tool center point movement path, and draws the actual machine movement. This allows the machine operation to be monitored during machining.

The programs that can be traced are operation searched machining programs (MDI program for MDI mode).

If no program has been operation searched, the trace window will not open.

Using [All display] menu, normal display and whole display modes can be switched.

■ Normal display ([All display] is OFF)

< Drawing area >

< Drawing area: 2-plane >

< Input area displayed >

- Full-screen display ([All display] is ON)
< Drawing area >

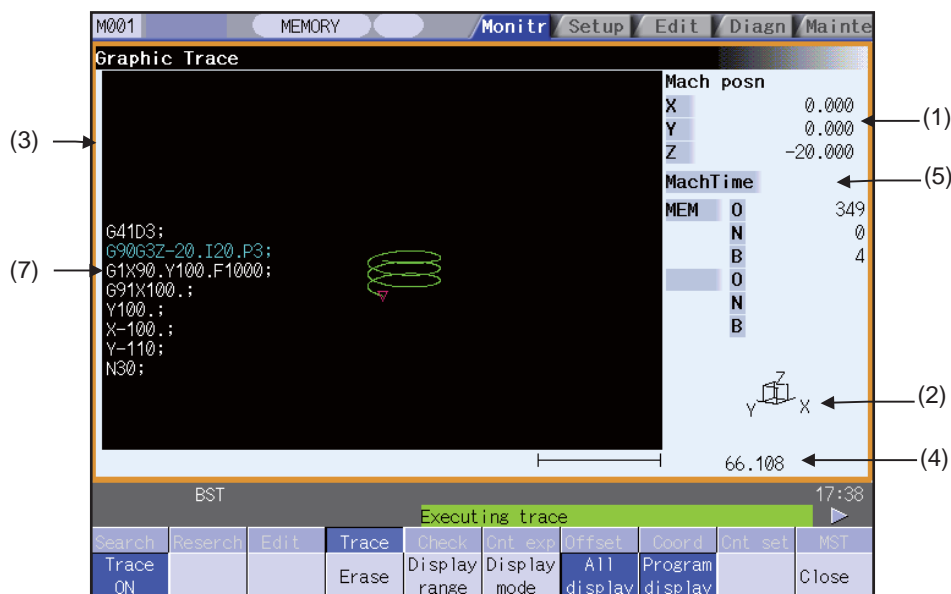

Display items

Display item	Details
(1) Counter	The counter of the axis targeted for the trace drawing is displayed. The three axes which are displayed are set with the parameters. The counter selected by the menu "Counter type" is displayed. When [Trace ON] is selected, the counter type to display can be designated. The setting is held even after the power is turned OFF and ON.
(2) Display mode	The plane currently being drawn is displayed.
(3) Trace drawing area	This area is used to draw the tool path as graphics. Zero-point mark for displaying can be selected with parameter "#19002 Zero-point mark display position".
(4) Scale	The display range scale is displayed.
(5) Machining time display	The time required for machining is calculated and displayed. Nothing is displayed during tracing.
(6) Input area	The input area appears when the menu [Display range] and [Display mode] are pressed. The scale value and display mode are set. The input area is hidden when the [INPUT] key is pressed.
(7) Program display	This displays the contents of the machining program currently being executed. The block being executed is highlighted.

Menus

Menu	Details	Type	Reference
Trace ON	This activates the trace mode. If any program is currently running, the machine position path is traced from the current position. If this menu is pressed during the machine position trace mode, the trace mode will be turned OFF.	B	2.5.1 Displaying the Machine Position Trace
Erase	This erases the data in graphic drawing area displayed on the screen.	C	
Display range	This changes the graphic drawing display range. When this menu is pressed, the menu changes to the display range change menu. When the display range is changed, the graphic data displayed on the screen is erased.	C	2.5.3 Changing the Display Range
Display mode	This changes the drawing plane. When this menu is pressed, the menu changes to the display mode change menu. There are three types of graphic display modes: 1-plane, 2-plane and 3D. When the drawing plane is changed, the graphic data displayed on the screen is erased.	C	2.5.4 Changing the Display Mode
All display	This switches the normal display mode and the full-screen display mode.	B	2.5.7 Switching the Full-screen Display Mode
Program display	This displays the machining program being executed on the graphic drawing area. This menu can be selected only when the full-screen display mode is applied.	B	
Rotate	This sets the viewpoint angle for the 3D display mode. When the viewpoint angle is changed, the graphic data displayed on the screen is erased. Note that this menu can be used only in the 3D display mode.	C	2.5.5 Changing the Display Angle
Std range	The display range (scale and display position) is automatically set from the machine movable area. The machine movable area is set with the parameters "#2013 OT-" and "2014 OT+" (software limit). When the display range is changed, the graphic data displayed on the screen is erased.	C	
Counter type	This displays the selected counter. For each trace mode, the counter type can be set separately. And the setting is held after the power is turned OFF and ON. However, if the [Trace ON] menu is not highlighted, this is displayed in gray and cannot be selected. The following counters can be selected. - Relat posn (Related position counter) - Work co posn (Workpiece coordinate position counter) - Machine posn (Machine position counter) - Remain command (Remain command counter) - Next command (Next command counter) - Program posn (Program position counter) - Tool posn (Tool position counter)	C	
Close	This closes the pop-up window and quits this function.	C	

2.5.1 Displaying the Machine Position Trace

Operation method

(1) Press the main menu [Trace ON].



- The [Trace ON] menu is highlighted.
- The machine position appears in the drawing area as a tool mark.
- The counter selected by [Counter type] menu is displayed at the counter.
- The message "Tracing" appears. After this, the machine position path is drawn with graphics in the trace mode.

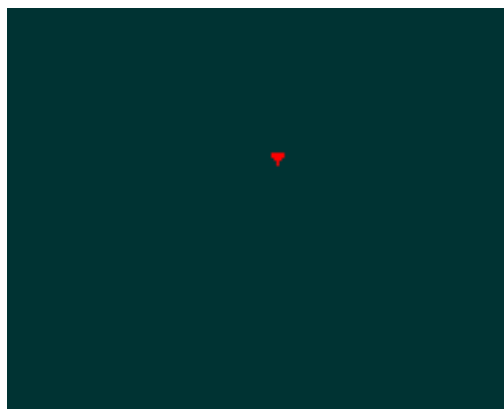

The path where the machine position or tool center position is drawn with graphics.

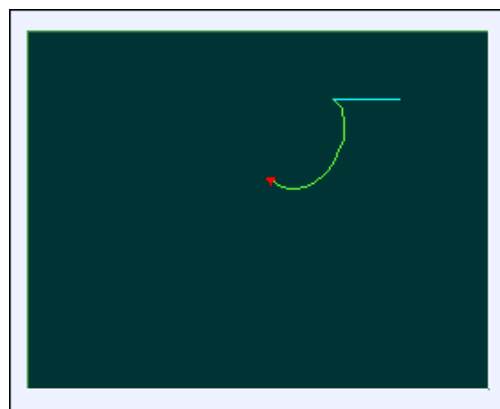

The path is drawn with a solid green line.

2.5.2 Canceling the Machine Position Trace

Operation method

(1) Start tracing with the machine position.

(2) Press the main menu [Trace ON].



- The [Trace ON] menu is unhighlighted.
- The tool mark in the drawing area is erased.
- The message "Tracing" is erased.

(Note) Even if the menu is unhighlighted, the displayed counter type does not change.

2.5.3 Changing the Display Range

The graphic drawing's scale can be enlarged or reduced, and the position moved or centered.

Operation method (Enlarging the and reducing the drawing)

- (1) Press the [Display range] key.  A white frame indicating the display range appears on the screen. The display range input mode is activated, and the following menu appears.

Zoom in	Zoom out	Up	Down	Left	Right	Centering			
---------	----------	----	------	------	-------	-----------	--	--	--

- (2) Press the menu [Zoom in] or [Zoom out].  The size of the white frame changes according to the key operations.

To enlarge the figure:
Press the menu [Zoom In] or the [-] key.
To reduce the figure:
Press the menu [Zoom out] or the [+] key.
A solid-line frame appears with respect to the original scale when enlarging, and a dotted-line frame appears when reducing.

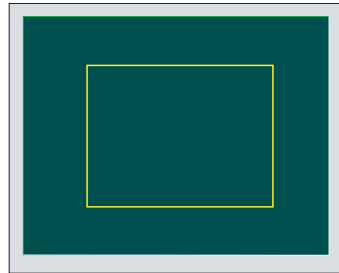

- (3) Press the [INPUT] key.  The display scale is changed. By changing the display scale, the graphic data displayed on the screen is erased.

(Note)The changed scale value is held even after the power is turned OFF and ON.

Operation method (Changing the drawing display position)

- (1) Press the [Display range] key.  A white frame indicating the display range appears on the screen. The display range input mode is activated, and the following menu appears.

Zoom in	Zoom out	Up	Down	Left	Right	Centering			
---------	----------	----	------	------	-------	-----------	--	--	--

- (2) Press the [Up], [Down], [Left], [Right] menu or cursor movement keys [↑] [↓] [←] [→]  The cursor (□) indicating the center of the display and the frame line move up, down, left and right according to the key operations.

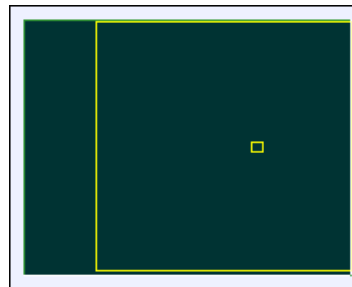

- (3) Press the [INPUT] key.  The display position changes so that the cursor position (□) is the center of the area. By changing the display position, the graphic data displayed on the screen is erased, however, the scale value is not changed.

- (Note 1) When changing the display range in the 2-plane display mode such as "XY/XZ", the display range (scale and display position) for the upper and lower areas changes in the same manner.
The operation method is the same as the 1-plane display mode.

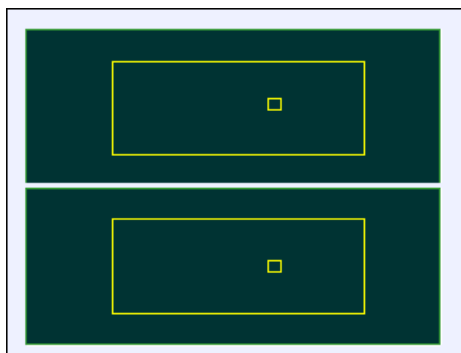

The white-framed display range in the upper and lower areas simultaneously move to the left/right when the [Left], [Right] keys are pressed.

The white-framed display range of either upper or lower areas moves up and down when the [Up], [Down] keys are pressed.

Which frame to be moved up/down can be changed with the page key.

Operation method (Centering)

- (1) Press the [Display range] key.



A white frame indicating the display range appears on the screen.
The display range input mode is activated, and the following menu appears.

Zoom in	Zoom out	Up	Down	Left	Right	Center- ing		
------------	-------------	----	------	------	-------	----------------	--	--

- (2) Press the [Centering] key.



The display position is changed so that the current machine position appears in the center of the drawing area.
When display position is changed, the graphic data displayed on the screen is erased.

- (Note 1) In the 2-plane display mode such as "XY/XZ", centering is applied for the upper and lower areas.
The operation method is the same as the 1-plane display mode.

2.5.4 Changing the Display Mode

The graphics display mode includes the 1-plane, 2-plane and 3D mode. When the menu [Display mode] is pressed and the following display mode menu is selected, the axis configuration of each plane changes, and the menu display returns to the original state. It is also possible to change the display mode by setting the axis name to the input area.

- (Note 1) When display mode is changed, the graphic data displayed up to that point are erased.
- (Note 2) The set display mode is held even after the power is turned OFF and ON.
- (Note 3) The display mode can be set independently for the trace function and program check function. These settings are not sequenced.
- (Note 4) The menu axis names XYZ correspond to the base axis IJK. X = base axis I, Y = base axis J, and Z = base axis K.

Display mode menus



Menu	Details	Type
XY	This changes to the 1-plane display mode configured of X-Y. The X axis is displayed as the horizontal axis, and the Y axis is displayed as the vertical axis.	C
YZ	This changes to the 1-plane display mode configured of Y-Z. The Y axis is displayed as the horizontal axis, and the Z axis is displayed as the vertical axis.	C
XZ	This changes to the 1-plane display mode configured of X-Z. The X axis is displayed as the horizontal axis, and the Z axis is displayed as the vertical axis.	C
XY/XZ	This changes to the 2-plane display mode configured of X-Y and X-Z. The X axis is displayed as the horizontal axis, and the Y axis and Z axis are displayed as the vertical axis.	C
YX/YZ	This changes to the 2-plane display mode configured of Y-X and Y-Z. The Y axis is displayed as the horizontal axis, and the X axis and Z axis are displayed as the vertical axis.	C
XYZ	This changes to the 3D display mode. A cube is displayed on the lower right of the screen.	C

Operation method (Changing the display mode)

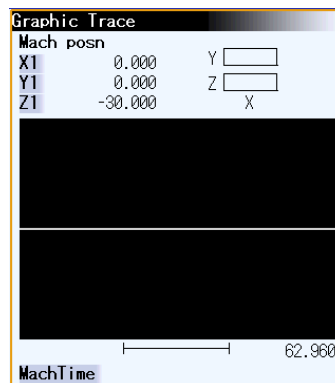
- (1) Press the menu [Display mode]. ➔ The menus for the selectable display modes appear. The input area appears.
- (2) Select the mode to display and press the menu. ➔ The display mode and drawing area appear as a 2-plane image.



Operation method (Changing the display axis name)

- (1) Press the menu [Display mode].  The menus for the selectable display modes appear. The input area appears.
- (2) Set the axis name, and press the [INPUT] key.  XYC appears as the axis name in the display mode. The X axis, Y axis and C axis are the three axes for drawing.

The display mode includes the 1-plane, 2-plane and 3D display modes. The display mode currently selected is shown with an image. The selected axis names are displayed in the image.

Display example

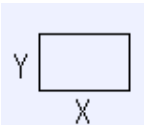
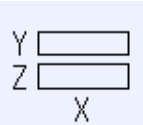
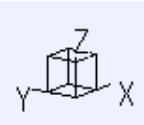
<1-plane> (XY)	<2-plane> (XY/XZ)	<3D> (XYZ)
		

2.5.5 Changing the Display Angle

Set the graphics display angle for the 3D display mode.

Press the menu key or the cursor movement keys, and rotate the cube displayed at the upper right of the screen. Set the angle by pressing the [INPUT] key.

(Note 1) When the display angle is changed, the graphics displayed up to that point are erased.

(Note 2) The set display angle is held even if the power is turned ON and OFF.



(Note 3) The display angle can be set independently for the trace function and program check function. These settings are not sequenced.

Operation method

- (1) Press the menu key [Rotate].  The rotation mode is activated, and the following menu appears.

Up	Down	Left	Right
----	------	------	-------
- (2) Use the [Up], [Down], [Left], [Right] menu to adjust the display angle.  The cube displayed at the lower right of the screen rotates according to the key operations.

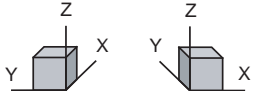
The cursor movement keys ([↑][↓][←][→]) can also be used to rotate.

- (3) Press the [INPUT] key.  The display angle is changed. When display angle is changed, the graphic data displayed on the screen is erased.

(Note 1) The set display angle is held even after the power is turned OFF and ON.

2.5.6 Switching the Axis Movement Direction (+, -)

Graphic trace draws the path according to the axis movement direction designated by "#1495 grf_ax_direction". The movement direction can be set for each axis.

Refer to "4.3.9 Switching the axis movement direction (+, -)" for details.

2.5.7 Switching the Full-screen Display Mode

Press the [All display] menu key to display the trace window on the whole screen. (full-screen display mode).
 Press this menu again to return the normal display.

Switching the display mode

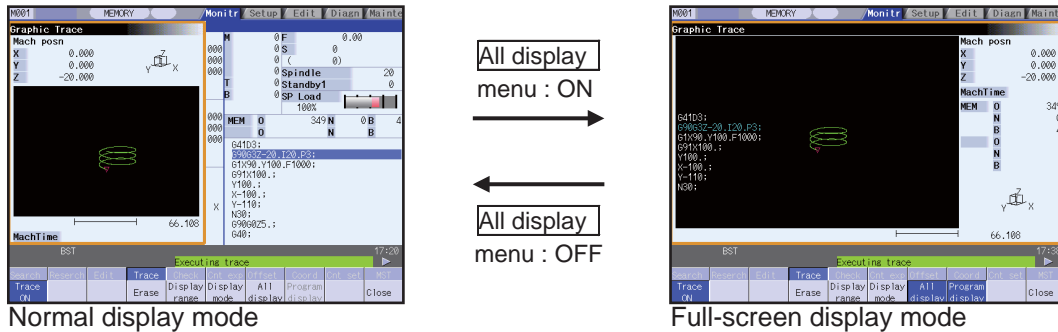

- (Note 1) The selected display mode is maintained even after rebooting the machine.
- (Note 2) The full-screen display mode is applied to the trace function and program check (2D) function commonly.

Displaying a program

When pressing the [Program display] menu key, the contents of the machining program currently being checked is displayed on the drawing area.

When pressing the [Program display] again, the displayed program is erased.

Note that this menu can be used only when the full-screen display mode is selected.

- (Note 1) The selected display mode is maintained even after rebooting the machine.
- (Note 2) The program display mode is applied to the trace function and program check (2D) function commonly.
- (Note 3) The [Program display] menu key cannot be selected while the normal display mode is selected. Program display mode is valid only when the full-screen display mode is selected.

2.5.8 Precautions for Tracing

- (1) When the command speed increases in the trace mode, the shape being drawn with graphics will become distorted. Especially, correct graphic drawing is not possible during machine lock.
 - (2) If program check (2D) is executed during the trace mode, the trace mode will be canceled.
 - (3) If trace is executed during program check mode, the program check will be canceled.
- Refer to section "4.3.15 Precautions for Program Check Function (2D)" for other precautions.

2.6 Program Check (2D)



Program check (2D) is a function that draws the machining program movement path without executing automatic operation. The machining program can be checked with graphic data drawn at a high speed. Using [All display] menu, normal display and full-screen display modes can be switched. The programs that can be checked are operation searched machining programs (MDI program for MDI mode). If no machining program has been operation searched, the program check window will not be opened. Refer to "4.3 Program Check (2D)" for details.

- Normal display ([All display] is OFF)
<Drawing area>

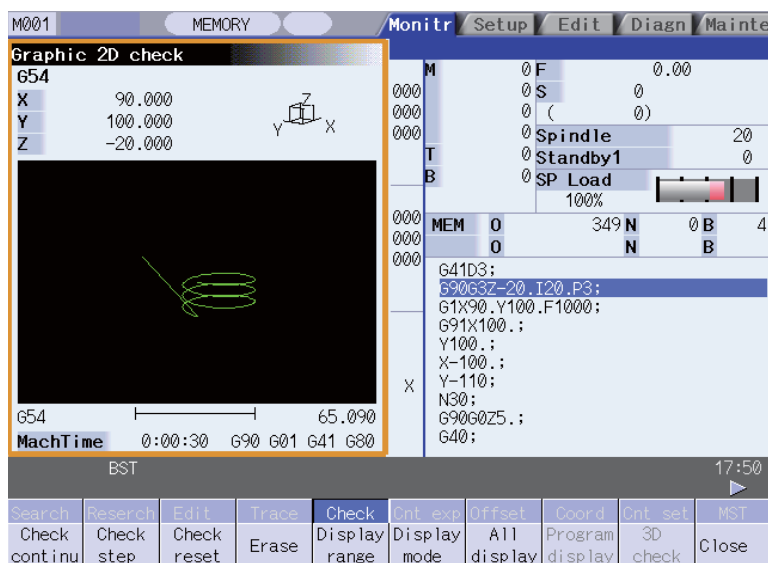

- Full-screen display ([All display] is ON)
<Drawing area>

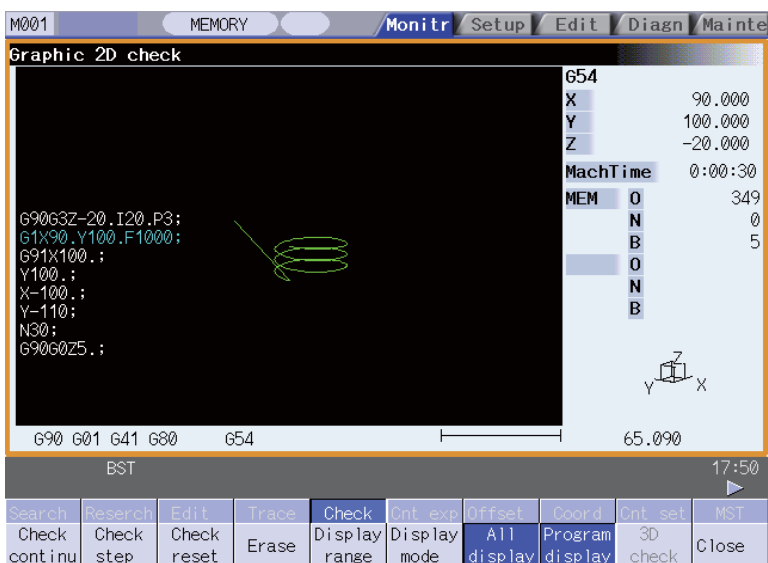

2.7 Counter All-axis Display



A counter for all axes opens as a pop-up display.
 The type of displayed counter can be selected with the menu.

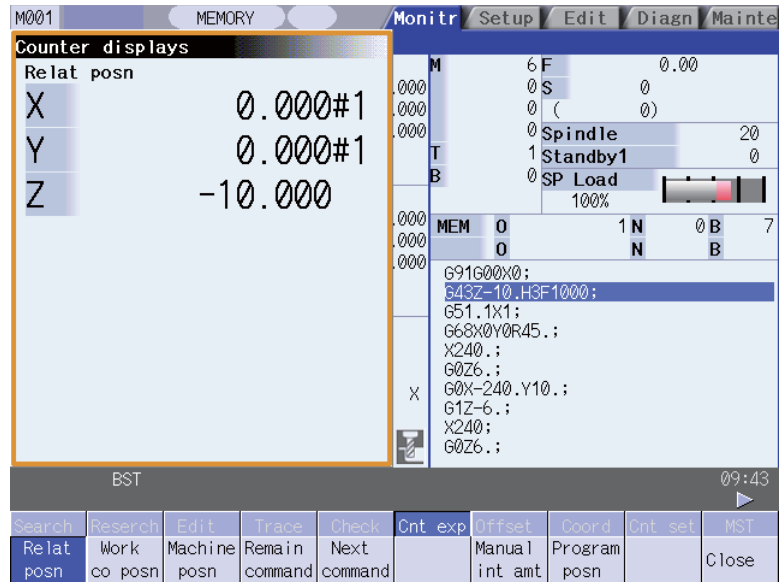

Menus

Menu	Details	Type
Relat posn	This displays the currently executed position	B
Work co posn	This displays the G54 to G59 workpiece coordinate system modal No. and the workpiece coordinate position in that workpiece coordinate system.	B
Machine posn	This displays the coordinate position of each axis in the basic machine coordinate system having a characteristic position, specified by the machine, as a zero point.	B
Remain command	This displays the remaining distance of the movement command being executed during automatic start or automatic halt. (The remaining distance is the incremental distance from the current position to the end point of that block.)	B
Next command	This displays the details of the command in the block executed after the block currently being executed.	B
Manual int amt	This displays the amount moved with the manual mode while the manual absolute switch was OFF.	B
Program posn	This displays the value obtained by subtracting the tool compensation amount compensated for that axis from the position actually being executed for each axis.	B
Close	This closes the pop-up window and quits this function.	C
Tip wk posn	In E70 series, this menu cannot be selected.	
Tip machine	In E70 series, this menu cannot be selected.	
Pulse	In E70 series, this menu cannot be selected.	
Table co posn	In E70 series, this menu cannot be selected.	
Wk Comp co posn	In E70 series, this menu cannot be selected.	
Incline co posn	In E70 series, this menu cannot be selected.	

(Note 1) The type of counter displayed first when the pop-up display appears is the relative position. The counter which appears next is the type selected previously.

2.8 Tool Compensation Amount



The tool compensation data can be set and displayed.

The tool compensation data screen configuration differs according to the tool compensation type.

Refer to section "3.2 Tool Compensation Amount" for details.

[Tool compensation type I (M system)] Parameter "#1037 cmdtyp" = 1

The combined amount of the shape compensation and wear compensation are set as the compensation data, with no distinction between shape compensation memory and wear compensation memory. (The tool compensation data is the shape compensation amount + wear compensation amount.)

The compensation data is used commonly for the tool length compensation, tool position offset, and tool radius compensation.

Tool offset					
Abs					
1	0.000	16	0.000	31	0.000
2	0.000	17	0.000	32	0.000
3	0.000	18	0.000	33	0.000
4	0.000	19	0.000	34	0.000
5	0.000	20	0.000	35	0.000
6	0.000	21	0.000	36	0.000
7	0.000	22	0.000	37	0.000
8	0.000	23	0.000	38	0.000
9	0.000	24	0.000	39	0.000
10	0.000	25	0.000	40	0.000
11	0.000	26	0.000	41	0.000
12	0.000	27	0.000	42	0.000
13	0.000	28	0.000	43	0.000
14	0.000	29	0.000	44	0.000
15	0.000	30	0.000	45	0.000

0 F 0.00
 0 S 0
 0 (0)
 0 Spindle 20
 0 Standby1 0
 0 SP Load 100%
 1 N 0 B 0
 N B
);
 YZ;
 49;
 0;
 .H3F1000;

RDY 10:11

Search Reserch Edit Trace Check Cnt. exp Offset Coord Cnt. set MST
 =Input +Input Offset Line Line Cnt. set MST
 No. copy paste Undo Close

[Tool compensation type II (M system)] Parameter "#1037 cmdtyp" = 2

The shape compensation amount and wear compensation amount are set separately. The shape compensation amount is furthermore divided into length and radius dimensions.

Of the compensation data, the length dimension data is used for the tool length compensation and tool position offset, and the radius dimension data is used for the tool radius compensation.

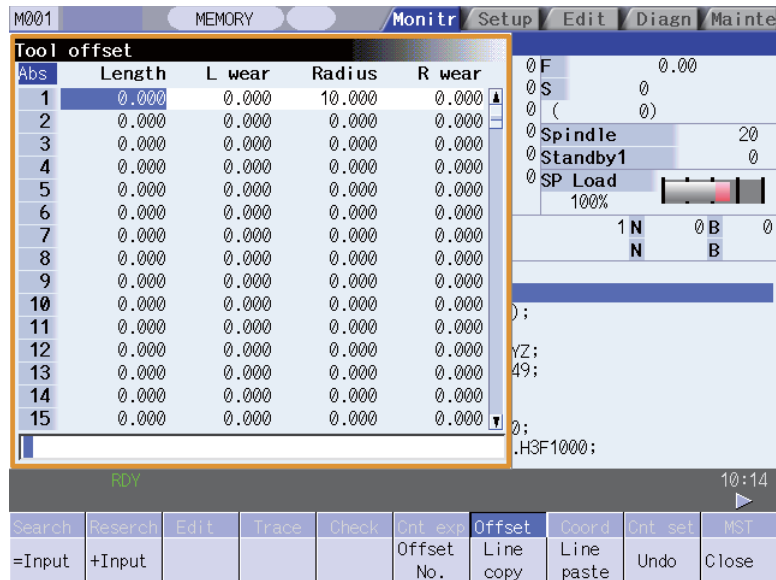

[Tool compensation type III (L system)] Parameter "#1037 cmdtyp" = 3

The wear data, tool length data and tool nose data are set separately. These are changed with the sub-menu.

(a) Wear data

Set the tool nose wear amount for each tool used. When the tool compensation No. is designated by the tool command (T command), compensation is carried out matching the tool length data and tool nose data.

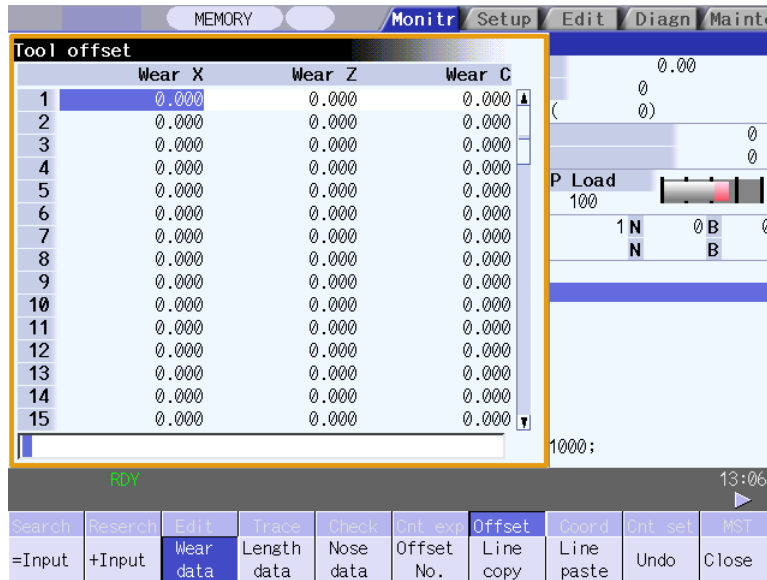

(b) Tool length data

Set the tool length in respect to the program basic position of each tool used.

When the tool compensation No. is designated by the tool command (T command), compensation is carried out matching the wear data and the tool nose data.

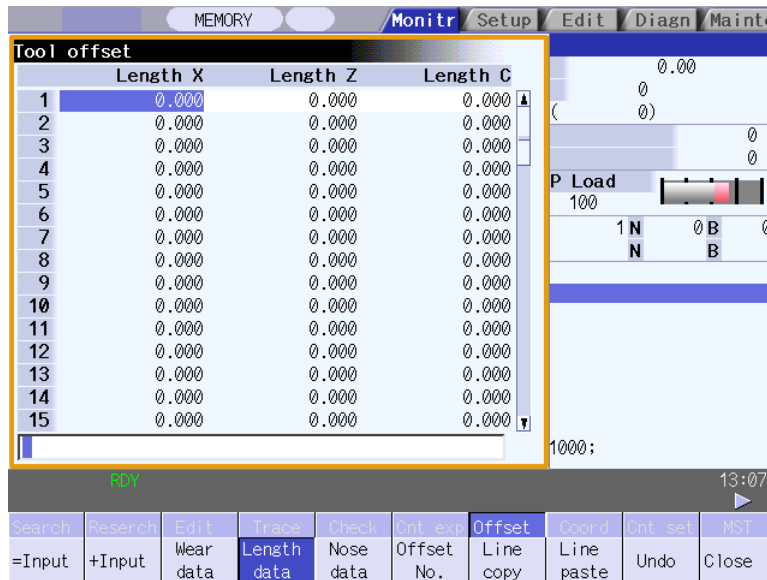

(c) Tool nose data

Set the tool nose radius value (tool nose R), wear radius value (R wear) and tool nose point (tool nose point P) of the tool nose mounted on the tool for each tool used. When the tool offset No. is designated by the tool command (T command), offset is carried out matching the tool length data and tool nose data.

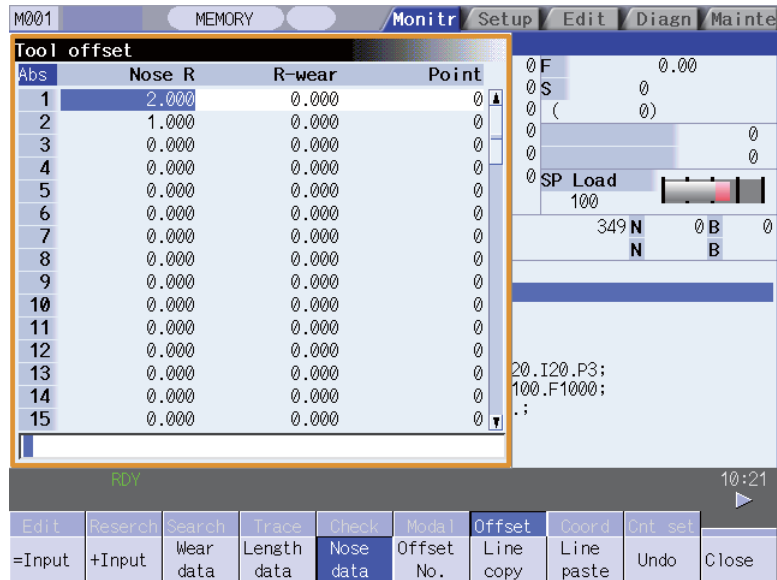

CAUTION

! If the tool offset amount or workpiece coordinate system offset amount is changed during automatic operation (including during single block stop), the changes will be valid from the command in the next block or after several subsequent blocks.

2.9 Workpiece Coordinate System Compensation



The coordinate system offset can be set and displayed.

6 sets of standard workpiece coordinate system offset and 48 sets of extended workpiece coordinate offset can be used. Refer to "3.6 Workpiece Coordinate System Offset" for details.

(Note 1) The G92/G52 coordinate system offset cannot be set.

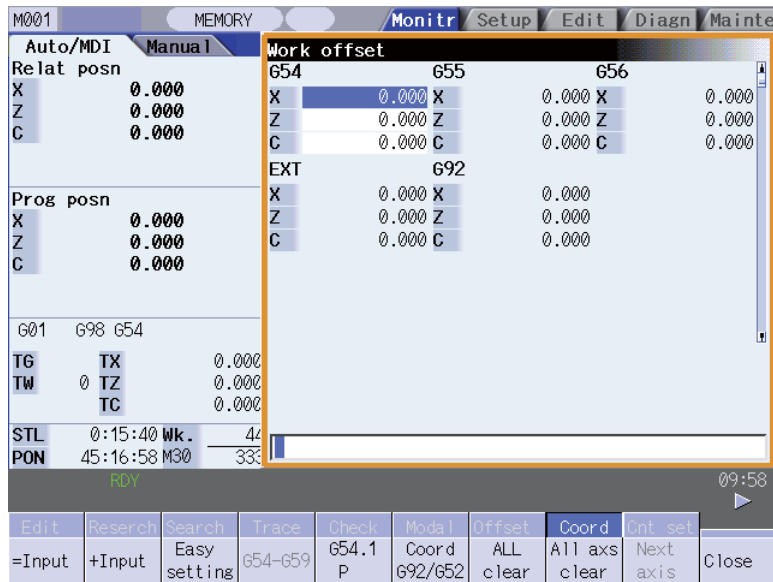

⚠ CAUTION

⚠ If the tool offset amount or workpiece coordinate system offset amount is changed during automatic operation (including during single block stop), the changes will be valid from the command in the next block or after several subsequent blocks.

2.10 Counter Setting



An arbitrary value can be set in the relative position counter which opens as a pop-up window. The counter cannot be set for an axis of auxiliary axis state.

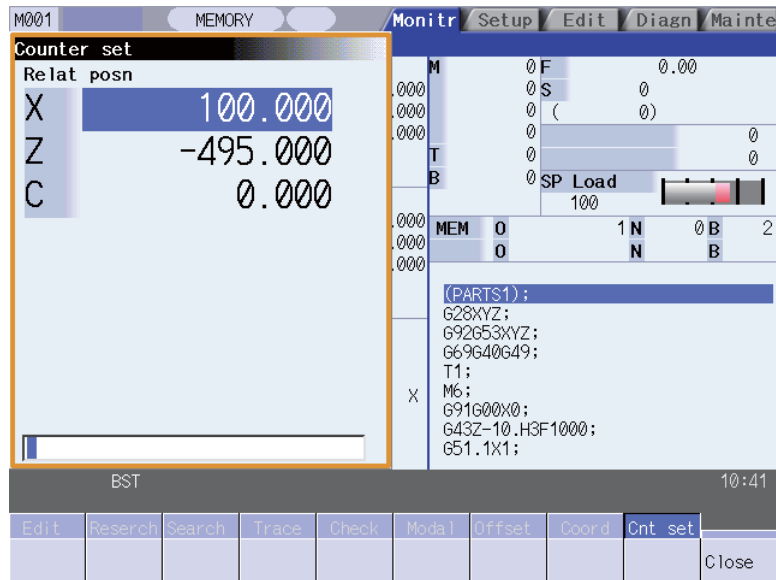

Menus

Menu	Details	Type	Reference
Close	This closes the pop-up window and quits this function.	C	

Operation method

- (1) Press the main menu [Counter set].



The relative position counter opens as a pop-up window. The cursor appears at the 1st axis of the relative position counter.

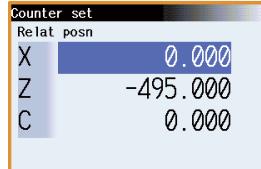

Instead of the operation above, the axis name address key can be pressed to set the counter. (Example) [Z]



The relative position counter opens as a pop-up window. The cursor appears at the designated axis (Z axis).

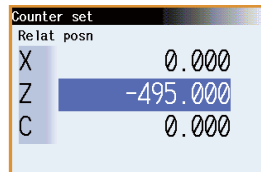

- (2) Using the [↑], [↓], or the key, move the cursor to the axis to be set.



The cursor moves.

- (3) Input a numeric value. (Example) 100.000 [INPUT]



The set value "100.000" appears at the cursor position. The cursor moves to the next axis.

If the [INPUT] key is pressed without inputting a value, zero (0) will be set.

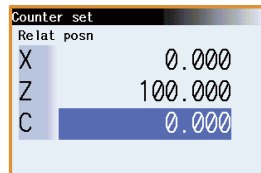

- (4) Repeat step (3) for each axis.



The pop-up window closes when the counter has been set for the last axis.

For axes that are not to be operated, press the [↓] key and move the cursor.



2.11 Origin Set, Origin Cancel

Origin set and origin cancel can be executed.

Origin set and origin cancel cannot be executed for an axis of auxiliary axis state.

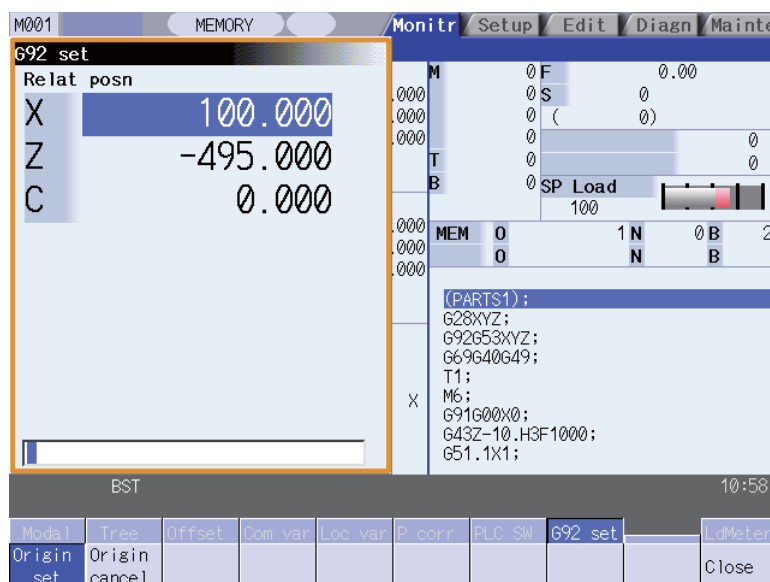

Menus

Menu	Details	Type	Reference
Origin set	The origin is set. When main menu [G92 set] is pressed, the menu [Origin set] is highlighted and the origin set mode is activated.	A	
Origin cancel	The origin is canceled. The origin cancel mode is activated when this menu is pressed.	A	
Close	This closes the pop-up window and quits this function.	C	

Differences between origin set and origin cancel

	Origin set	Origin cancel
Function	The coordinate system is shifted so the current position becomes the designated position of the workpiece coordinate system. This is equivalent to "G92 X0". (When X is the target axis.)	The coordinate system is shifted so the zero point of the workpiece coordinate system matches the zero point of the basic machine coordinate system. This is equivalent to "G92 G53 X0". (When X is the target axis.)
Changes in the counter value	The relative position counter and workpiece coordinate counters become "0".	The relative position counter matches the machine coordinate counter.
Offset	The G92 shift amount is updated.	The G92 shift amount and the G52 shift amount for the G54 to G59 coordinate system becomes "0".

Operation method (Setting the origin)

- (1) Press the main menu [G92 set].



The relative position counter opens as a pop-up window. The menu [Origin set] is highlighted. The cursor appears at the 1st axis of the relative position counter.

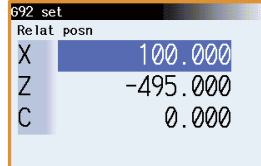

- (2) Using the [↑], [↓], or keys, move the cursor to the axis to be set.



The cursor moves.

- (3) Input 0, and then press the [INPUT] key.



"0.000" appears at the cursor position. The cursor moves to the next axis.

If the [INPUT] key is pressed without inputting a value, zero (0) will be set. (Origin zero)

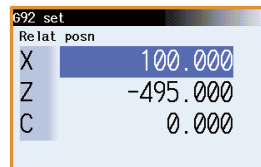

- (4) Repeat step (3) for each axis.



The pop-up window closes when the origin has been set for the last axis.

For axes that are not to be operated, press the [↓] key and move the cursor.

(Note) An error will occur if a value other than 0 is set.

Operation method (Canceling the origin)

- (1) Press the main menu [G92 set], and then press the menu [Origin cancel].



The relative position counter opens as a pop-up window. The menu [Origin cancel] is highlighted. The cursor appears at the 1st axis of the relative position counter.

- (2) Press the [INPUT] key.



The same value as the machine position appears at the cursor position. The cursor moves to the next axis.

- (3) Repeat step (2) for each axis.



The pop-up window closes when the origin has been canceled for the last axis.

For axes that are not to be operated, press the [↓] key and move the cursor.

2.12 Manual Numerical Value Command



The spindle function (S), miscellaneous function (M), tool function (T) and 2nd miscellaneous function (B) commands can be executed.

The manual numerical value command can be executed by inputting an address such as S, M, T or B, as well.

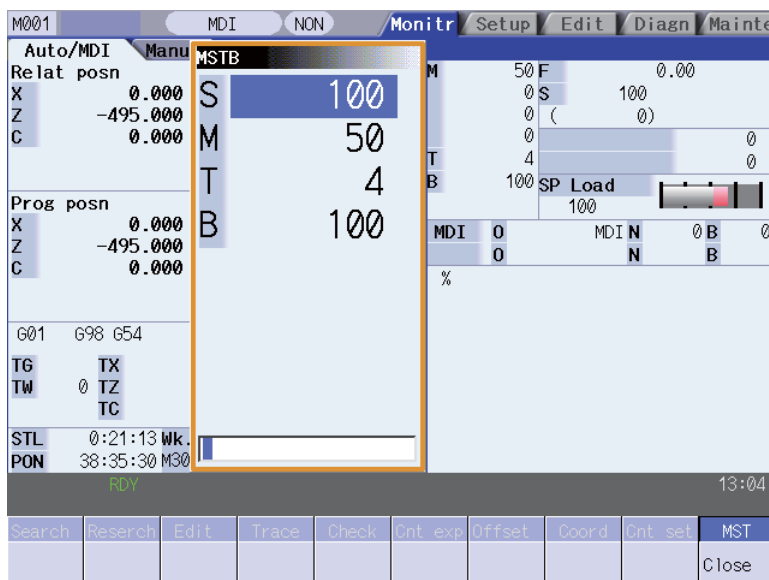

Menus

Menu	Details	Type	Reference
Close	This closes the pop-up window and quits this function.	C	

Operation method (Executing T31 with a manual numerical value command)

(1) Press the main menu [MST].



The S, M, T, B display opens as a pop-up window.

S	100
M	50
T	4
B	1000

Using the [↑] and [↓] keys, move the cursor to the position to be set.



The cursor moves.

(2) The manual numerical value command can also be issued by using the address keys instead of the operation above.
(Example) [T]



The S, M, T, B display opens as a pop-up window. The cursor appears at T.

S	100
M	50
T	4
B	1000

(3) Input a value.
31 [INPUT]



The input value is set.

Operation method (Canceling the manual numerical value command)

The manual numerical value command mode is canceled by carrying out one of the following operations before pressing the [INPUT] key.

- Press the menu [Close]
- Press the key
- Change the screen

Setting/output range of manual numerical value command

For each S, M, T and G command, the data type to output to PLC program is designated by parameters "#12006 Mbin M binary", "#12008 Sbin S binary", "#12010 Tbin T binary" and "#12012 Bbin B binary".

The output data type and the manual numerical value command setting/output range are shown below.

		BCD	No-signed binary	Signed binary
Output range	S	-	0 to 99999999	-99999999 to 99999999
	M			
	T	0 to 99999999		
	B			

- (Note 1) Even if the parameter (#12008 Sbin S binary) is set to "0" (BCD), the signed binary output is applied to S. BCD output is not applied.
- (Note 2) If a negative value is set when the data type is "BCD type" or "No-signed binary type", a value converted into positive value is output to PLC program.
- (Note 3) Add a "-" sign before the value to set a negative value. The display will be a positive value.
- (Note 4) A value larger than "#3001 slimt1" to "#3004 slimt4" or "#3005 smax1" to "#3008 smax4" cannot be output for S.



2.13 Modal Display

The state of each modal during automatic operation is displayed.
The displayed details differ for the M system and L system.

<M system>

The screenshot displays the following modal information:

Code	Value
G00	G17 G90 G23 G94
G21	G40 G43 G80 G98
G50	G54 G64 G67 G40.1
G69	G97 G15 G50.1
G50	: P = 0.000000 G54 :P0
G69	: R = 0.000 G54.4:P0
G40	: D =
G43	: Z H 1= 0.000: 0.000
G05	:P0 G120.1 P0

Additional indicators and values shown:

- Spindle Standby: 20
- SP Load: 100%
- MEM: 51 N 0 B 6
- Modal indicators: S, M, T, B
- Modal codes: G0054G90X15.Y0; G43Z5.H1; G02I-15.Z-100.F2000; G02I-15.; G01; X25.; G02I-25.; G01X40.; G02I-40.; G025.;

Display items

This displays each modal state.

Display item	Details
(1) Gxx···Gxx : Gxx···Gxx	Status of currently executed G command modal
(2) G50:P=	Scaling magnification
(3) G54.1:P	Extended workpiece coordinate system
(4) G69:R=	Coordinate rotation angle (Displays within a $\pm 360^\circ$ range)
(5) G40: D0 = xxxx: xxxx	Tool radius compensation modal Compensation No. Shape compensation amount in respect to tool radius Tool radius wear amount
(6) G49: Z H0 = xxxx: xxxx	Tool length compensation modal Compensation axis name Compensation No. Compensation amount Tool length wear amount
(7) FA FM	F modal value of currently executed program command Manual federate
(8) S1 to S4 M1 to M4 T B	Program command modal value of each currently executed command S command M command T command 2nd miscellaneous function (B) command

<L system>

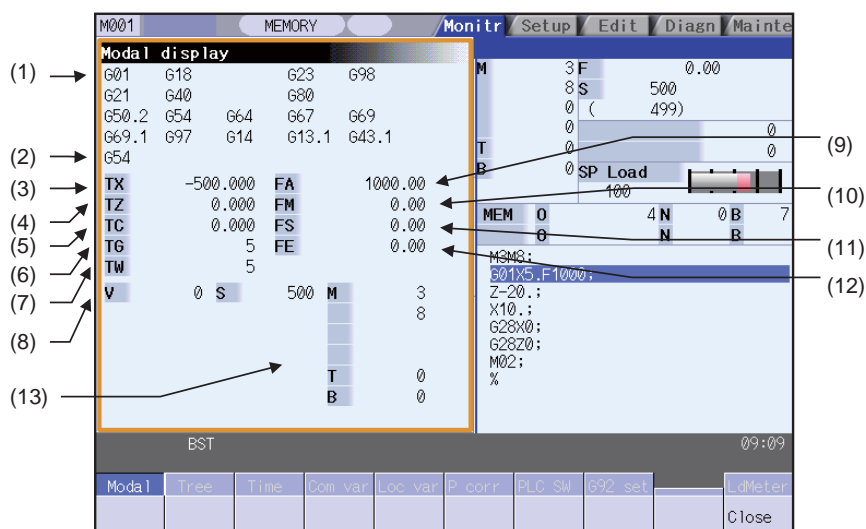

Display items

This displays each modal state.

Display item	Details
(1) Gxx...Gxx : Gxx...Gxx	Status of currently executed G command modal
(2) G54.1:P	Extended workpiece coordinate system
(3) TX;	The total value of the first axis' tool length and wear compensation amount for the tool being used
(4) TZ;	The total value of the second axis' tool length and wear compensation amount for the tool being used
(5) TC;	The total value of the additional axis' tool length and wear compensation amount for the tool being used
(6) TG;	Tool length compensation No.
(7) TW;	Wear compensation No.
(8) V	Modal value for constant surface speed spindle rotation speed (V1 to V6)
(9) FA	F modal value of currently executed program command
(10) FM	Manual federate
(11) FS	Program command synchronous feedrate modal value
(12) FE	Thread lead command synchronous feedrate modal value
(13) S1 to S6 M1 to M4 T1 to T2 B	Program command modal value of each currently executed command S command M command T command 2nd miscellaneous function (B) command

(Note) Fixed cycle programs

When a fixed cycle command is executed, the G command in the fixed cycle subprogram is not affected by the G modal in the called program.

Menus

Menu	Details	Type	Reference
Close	This closes the pop-up window and quits this function.	C	

(Note) The menu is common for the M system and L system.

2.14 Program Tree Display



This displays the main program, subprogram, MDI interrupt and user macro call nesting structure.

This also displays the execution position of the main program and the subprogram (the lowest level of the nest only) as a percentage during the automatic operation.

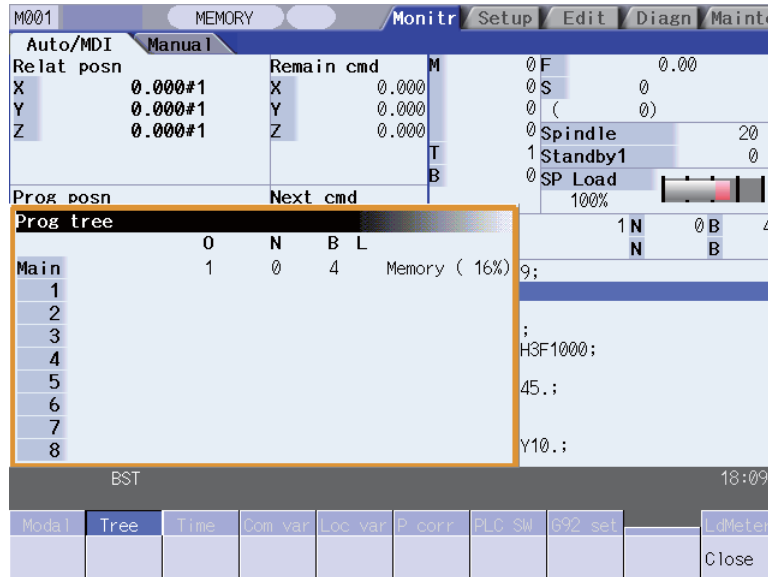

Display items

Display item	Details
(1) O	Program No. (0 to 15 characters) If the program No. (program name) exceeds 15 characters, "*" will appear at the 15th character.
(2) N	Sequence No. (0 to 99999)
(3) B	Block No. (0 to 99999)
(4) L	Remaining number of subprogram repetitions (0 to 99)
(5) Mode	Operation mode (0 to 7 characters)
(6) Main	Main program
(7) 1 to 8	Called subprogram, user macro call and MDI interrupt
(8) (%)	Assuming the whole machining program size as 100%, the execution position during an automatic operation will be displayed in % (percentage). When the automatic operation is not executed, 0% will be displayed for the main program's percentage display. The subprogram's percentage will be displayed only for the lowest level of the nest and other subprograms will display blank.

Menus

Menu	Details	Type	Reference
Close	This closes the pop-up window and quits this function.	C	



2.15 Integrated Time Display

The integrated time (date, time, power ON time, automatic operation time, automatic start time, external integrated time 1, external integrated time 2, cycle time) controlled by the NC can be set and displayed.

Note that the cycle time cannot be set. (Cycle time is display only.)

The integrated times displayed in cycle time display area on "Auto/MDI" tag can be set.

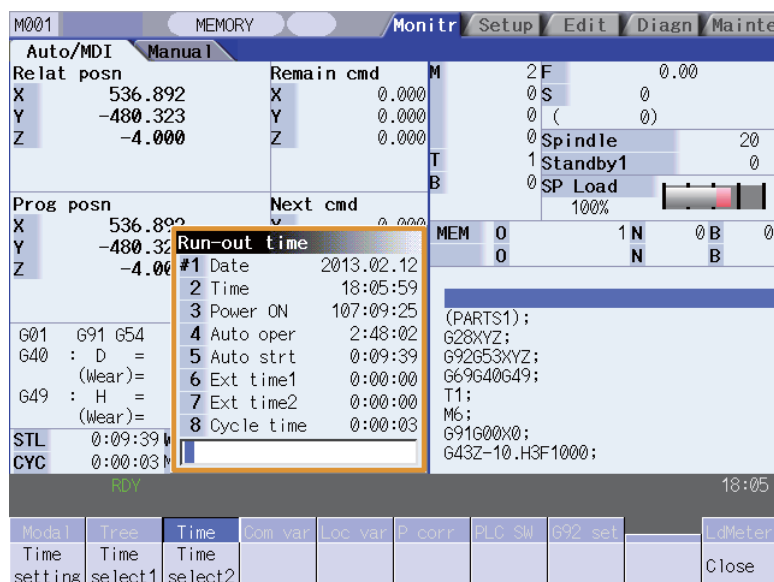

Display items

Display item	Details
(1) #1 Date	The current date set in the NC is displayed. Year: 4 digits, Month: 2 digit, Date: 2 digit (YYYY.MM.DD)
(2) 2 Time	The current time set in the NC is displayed with the 24-hour system. (HH:MM:SS)
(3) 3 Power ON	This displays the total integrated time of the time from NC power ON to OFF. (HHHH:MM:SS)
(4) 4 Auto oper	This displays the total integrated time of the work time from automatic start button pressing in the memory (tape) mode to M02/M30 or reset button pressing (HHHH:MM:SS)
(5) 5 Auto strt	This displays the total integrated time during automatic starting from automatic start button pressing in the memory (tape) mode or MDI to feed hold stop, block stop, or reset button pressing. (HHHH:MM:SS)
(6) 6 Ext time1	This content differs depending on machine tool builder specification. (HHHH:MM:SS)
(7) 7 Ext time2	This content differs depending on machine tool builder specification. (HHHH:MM:SS)
(8) 8 Cycle time	This displays the time that automatic operation is started from when the automatic start button is pressed in the memory (tape) mode or MDI to when feed hold stop or block stop is applied or the reset button is pressed.



(Note) When the #3 Power ON to #8 Cycle time displays reach the maximum value (9999:59:59), the count stops, and the maximum value remains displayed.

Menus

Menu	Details	Type	Reference
Time setting	This sets the integrated time.	A	2.16.1 Setting the Integrated Time
Time select1	The time that is displayed in upper line on cycle time display area is selected.	C	2.16.2 Setting the Time Display Selection
Time select2	The time that is displayed in bottom line on cycle time display area is selected.	C	
Close	This closes the pop-up window and quits this function	C	

2.15.1 Setting the Integrated Time

Operation method

- (1) Press the menu [Time setting].  The time setting mode is entered.
The cursor appears at the "#1 Date" position in the integrated time display.
- (2) Input today's date.  "2012.12.03" appears at "#1 Date", and the cursor moves to "#2 Time".
(Example) 2012/12/03 [INPUT]
- (3) Set the data for each item, and press the [INPUT] key.  When "#7 External integrated time 2" has been set, the cursor disappears, and the time setting menu highlight is turned OFF.
If the item does not need to be set, press the [↓] key and move the cursor.
Note that #8 Cycle time cannot be set, so the cursor will not move.

(Note 1) The data delimiters are as shown below.

Item	Valid delimiters during setting	Delimiters in display
#1 Date	". " or " / "	". "
#2 Time to #7 Ext time2	". " or " / "	". "
#8 Cycle time		". "

(Note 2) If the [Time setting menu] or  key is pressed again during the time setting mode, the time setting mode will be canceled.

Setting range



Display item	Range
#1 Date	1980.1.1 to 2069.12.31
2 Time	00:00:00 to 23:59:59
3 Power ON	00:00:00 to 59999:59:59
4 Auto oper	
5 Auto strt	
6 Ext time 1	
7 Ext time 2	

2.15.2 Setting the Time Display Selection

The displayed time is set on cycle time display area.

Operation method

- (1) Press the menu "Time select1"  The time selection mode is activated, and the following menu appears.

Date	Time	Power ON	Auto oper	Auto strt	Ext time1	Ext time2	Cycle time
------	------	----------	-----------	-----------	-----------	-----------	------------
- (2) Press the time type for the mode to display.
(Example) "Auto oper"  The automatic operation time is displayed in upper line on cycle time display area. The menu display returns to integrated time sub-menu.
- (3) Press the menu "Time select2"  The time selection mode is activated, and the following menu appears.

Date	Time	Power ON	Auto oper	Auto strt	Ext time1	Ext time2	Cycle time
------	------	----------	-----------	-----------	-----------	-----------	------------
- (4) Press the time type for the mode to display.
(Example) "Power ON"  The automatic operation time is displayed in bottom line on cycle time display area. The menu display returns to integrated time sub-menu.

(Note 1) The displayed time is held even after the power is turned OFF and ON.

2.16 Common Variables



The details of the common variables can be set and displayed on this screen.

If there is a common variable command (Note) in the machining program, the variable value (variable name) set when the block is executed is displayed.

The number of common variable sets differs according to the specifications.

(Note) The variable names can be set for common variables #500 to #519.

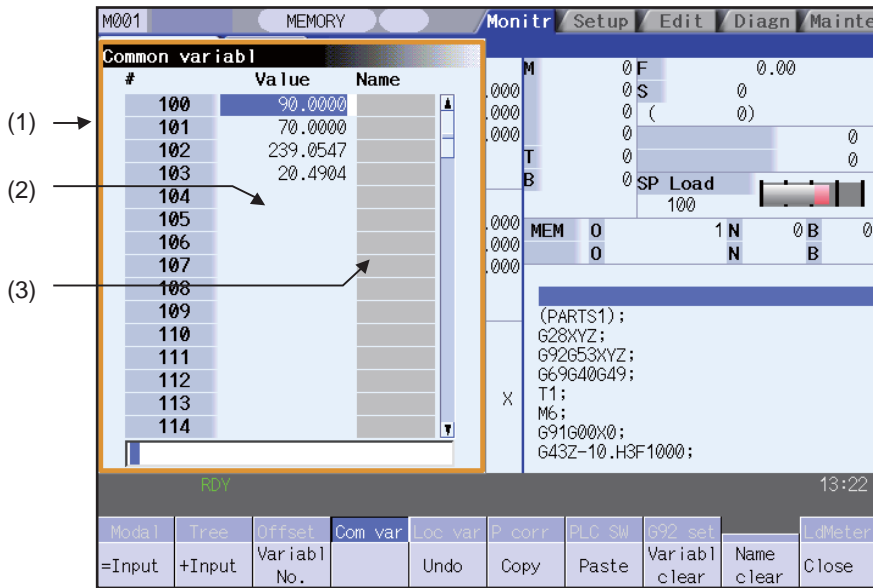

Display items





Display item	Details						
(1) Variable No.	<p>This is the common variable No. There are common variables 1 (#500 to #549) and common variables 2 (#100 to #199). The #100 variables appear at the head when the power is turned ON.</p> <table border="1"> <thead> <tr> <th></th> <th>Common variable 1</th> <th>Common variables 2</th> </tr> </thead> <tbody> <tr> <td>200 sets</td> <td>500 to 599</td> <td>100 to 199</td> </tr> </tbody> </table>		Common variable 1	Common variables 2	200 sets	500 to 599	100 to 199
	Common variable 1	Common variables 2					
200 sets	500 to 599	100 to 199					
(2) Variable value	<p>The setting range is -999,999,999 to 999,999,999 or blank. An exponential is displayed when a 7 digits are set in the integer section and 5 digits or more as set in the decimal section. (Example) 1234567 1.2346E+006, 0.00001 1.0000E-005 The minimum setting unit that can be set is 1.0000E-099 (99 digits below decimal point). (Note)When the setting is "blank", the setting will be handled as "0" in the calculations. However, when the conditional expressions EQ or NE are used, the blank will not be handled as "0".</p>						
(3) Variable name	<p>A variable name can be assigned for #500 to #519. Up to seven alphanumeric characters, starting with an alphabet character, can be set for the variable name.</p>						

Menus

Menu	Details	Type	Reference
=Input	This executes an absolute input. If "#8930 Disable=INPUT:var" is set to "1", this menu cannot be selected.	C	2.16.1 Setting Common Variables
+Input	This executes an addition input.	C	
Variabl No.	This designates the variable No. to be displayed at the head. Common variables 1 (#500 to #549) and common variables 2 (#100 to #199) are displayed in each area. When another area is displayed, press this menu and specify the common variable No.	A	
Undo	This returns the last rewritten data to its original value. This menu key is valid for "Data Input", "Paste" and "Undo" operations. Note that return to the original value is not possible after variable clear and comment clear operations. (Note) When an operation parameter "#8939 Undo confirm msg" is set to "1", the menu is highlighted while the operation message is displayed.	C/A	
Copy	This copies the variable value and variable name at the cursor position.	A	2.16.2 Copying/Pasting Common Variables
Paste	This pastes the copied variable value and variable name.	C	
Variabl clear	This clears the contents of the variable No. at the cursor position or continuous variable Nos. (Note) The contents are not cleared to "0". The state with no data is entered.	A	2.16.3 Erasing Common Variables
Name clear	This clears the variable No. at the cursor position or the continuous variable number's variable name (Variable name: variable No. 500 to 519).	A	
Close	This closes the pop-up window and quits this function.		

2.16.1 Setting Common Variables





Operation method (Setting "135.000" in variable No. 102)

- (1) Press the menu [Variabl No.]  The menu is highlighted.
- (2) Designate the variable No.
102 [INPUT]  The common variable for the set No. appears at the head.
The cursor can be moved to 102 using the [↑], [↓],  and  keys.
- (3) Input a value.
135 [INPUT]  The set value appears.
The value can also be set by pressing the menu [=INPUT] instead of the [INPUT] key.
The value can also be input as an exponential.
(1.35E2 [INPUT] or 1.35E2 [=INPUT].)

Operation method (Adding "1.234" to variable No. 102)

- (1) Select common variable 102 with the same procedure as steps (1) and (2) above.
- (2) Input a value.
1.234 [+INPUT]  The value obtained by adding the input value to the original value appears.
(Example) If the original value is 135.000, 136.234 appears.
(135.000 + 1.234 = 136.234)



Operation method (Setting "COUNTER" as the variable name for variable No. 509)

- (1) Select common variable 509 with the same procedure as steps (1) and (2) above.  The cursor appears at the cursor 509 variable position.
- (2) Press the  key.  The cursor moves to the 509 variable name.
- (3) Input the variable name.
COUNTER [INPUT]  "COUNTER" appears.

(Note) The variable name can be set only for variable Nos. 500 to 519.

2.16.2 Copying/Pasting Common Variables

Operation method

- (1) Select the variable to be copied.  The cursor moves to the selected variable.
One of the following methods can be used to select the variable.
- Using the cursor movement keys
[↓] and [↑], move the cursor to the variable to be selected.
- Press [Variabl No.] and set the variable No. in the input area, and press the [INPUT] key.
- (2) Press the menu [Copy] .  One line of the copied variable is highlighted.
- (3) Select the variable to be pasted, and press the menu [Paste].  The copied variable is pasted, and the highlight returns to normal.
The copied variable is held until a variable is newly copied.

2.16.3 Erasing Common Variables

Operation method (Erasing the variable value for variable number 102 to 104)

- | | | |
|---|---|--|
| (1) Press the menu [Variabl clear] . | ➔ | The menu is highlighted. |
| (2) Input the No. (range) of the variable to be erased.
102/104 [INPUT]

To erase only one variable, input one variable No.
(102 [INPUT]) | ➔ | A message confirming the erasing appears.
The background color of the erase range (variable value) changes to light blue. |
| (3) Press the [Y] key. | ➔ | The selected variable is erased. |

Operation method (Erasing the variable name for variable No. 509)

- | | | |
|--|---|---|
| (1) Press the menu [Name clear] . | ➔ | The menu is highlighted. |
| (2) Select the variable , and press the [INPUT] key
509 [INPUT] | ➔ | A message confirming the erasing appears.
The background color of the erase range (variable name) changes to light blue. |
| (3) Press the [Y] key. | ➔ | The variable name for 509 only is erased.
The variable value is not erased. |

Precautions regarding erasing the variable value and variable name

The variable at the cursor position will become the target of the erasing if the [INPUT] key is pressed without designating a variable No.

2.16.4 Switching the Display Area

Methods to switch the display areas are as follows.

- (1) Use the menu [Variabl No.]. (Refer to "2.17.1 Setting Common Variables".)
- (2) Use the page changeover key.
 - If you press the next page key during displaying the last page of the area, the first page of the next area will be displayed.
 - If you press the previous page key during displaying the first page of the area, the last page of the previous area will be displayed.

(Example) If you press the next page key during displaying the last page of the common variable common variable 2 (#100 -), the first page of the common variables common variable 1 (#500 -) will be displayed.
- (3) Use a cursor key
 - When a cursor key is placed at the biggest variable No. in the area, the first page in the next area will be displayed by pressing [↓] or [→].
 - When a cursor key is placed at the first variable No. in the area, the biggest variable No. in the previous area will be displayed at the top by pressing [↑] or [←].
- (4) Use a scroll bar
 - The first page of the next area will be displayed by pressing ▼ , while the last page of the area is displayed.
 - The biggest variable No. in the previous area will be displayed at the head by pressing ▲ , while the first page is displayed.

Variable numbers cannot be displayed continuously if another display area is inserted in between.

2.17 Local Variables



The details of the local variables are displayed

Local variables 1 to 33 are prepared for each user macro subprogram call level. Up to 33 local variable data items are displayed on one level. A 5-level configuration from level 0 to level 4 is used in page order. If there is a local variable command or an argument designation called by the user macro subprogram in the block, and that block is executed first, the set variable value (variable name) will be displayed.

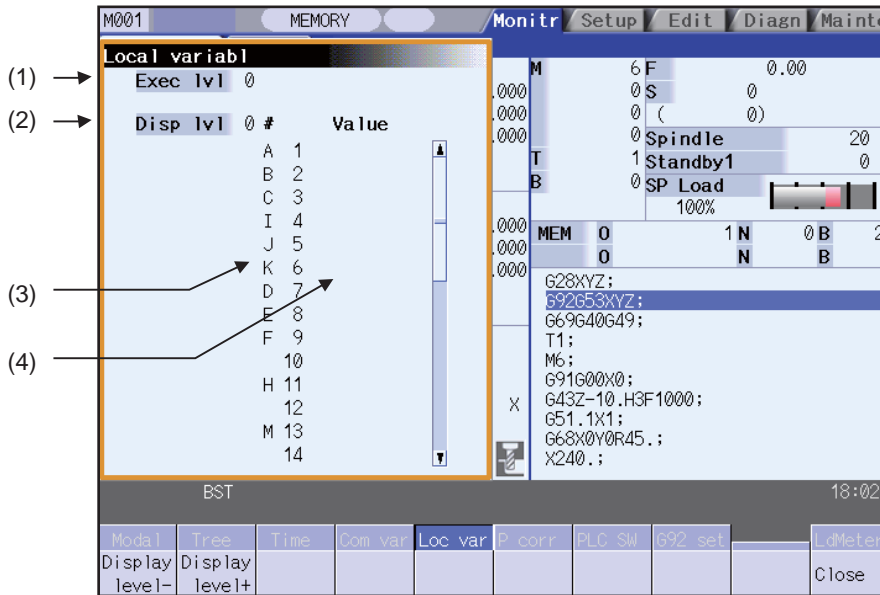

Display items

Display item	Details
(1) Execution level	This displays the nest level of the subprogram control called by the user macro. 0 : Not in user macro call state 1 : User macro call level 1 2 : User macro call level 2 3 : User macro call level 3 4 : User macro call level 4
(2) Display level	This displays the nest level of the local variable displayed in the area.
(3) Variable No.	This displays the local variable No. The alphabetic character before the local variable No. is the argument code. G, L, N, O and P cannot be used as arguments, and thus not displayed. There are 33 local variables (1 to 33) for each user macro subprogram call level.
(4) Variable value	This displays the local variable value. If the variable data is "blank", the display will be blank. An exponential is displayed when a 7 digits are set in the integer section and 5 digits or more as set in the decimal section. (Example)1234567 → 1.2346E+006, 0.00001 → 1.0000E-005 (Note)When the setting is "blank", the setting will be handled as "0" in the calculations. However, when the conditional expressions EQ or NE are used, the blank will not be handled as "0".

Menus

Menu	Details	Type	Reference
Display level-	This lowers the local variable display level one by one. If this menu is pressed when the display level is 0, the level changes to display level 4.	C	2.18.1 Displaying the Arbitrary Local Variables
Display level+	This increases the local variable display level one by one. If this menu is pressed when the display level is 4, the level changes to display level 0.	C	
Close	This closes the pop-up window and quits this function.	C	

Relation of user macro subprogram call execution level and display level

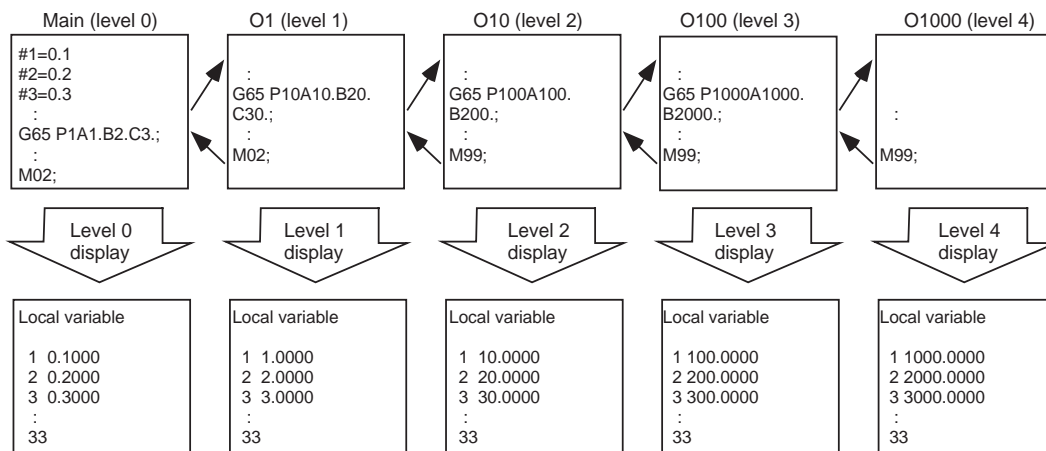

Precautions

The local variables are not erased when reset or when the power is turned OFF. They are erased at macro call.

2.17.1 Displaying the Arbitrary Local Variables

Operation method (Displaying the next level)

When the current display level is 0

- (1) Press the menu [Display level +].  The level 1 local variables appear from the head.

When the menu [Display level +] is pressed again, the display level changes in the order of 2 →3→4→0→1→2→... and so forth.



Operation method (Displaying the previous level)

When the current display level is 2

- (1) Press the menu [Display level -].  The level 1 local variables appear from the head.

When the menu [Display level -] is pressed again, the display level changes in the order of 0→4→3→2→1→0→... and so forth.

Operation method (Changing the displayed variable No.)

The displayed local variable No. changes when the page changeover keys (previous page  , next page ) are pressed.

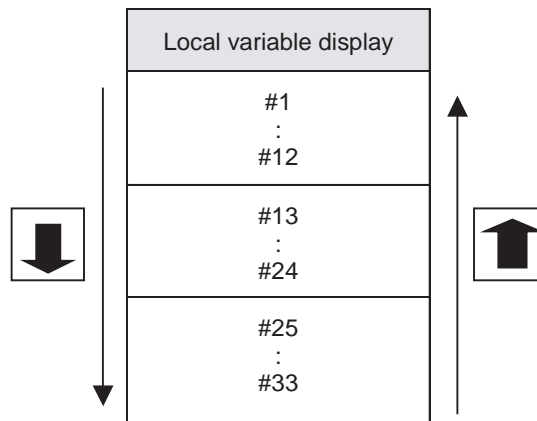

2.18 Buffer Correction



During automatic operation (Memory, memory card) or MDI operation, a block stop can be applied, and the next command can be corrected or changed.

When a program error occurs, the block in which the error occurred can be corrected without resetting the NC, and operation can be continued.

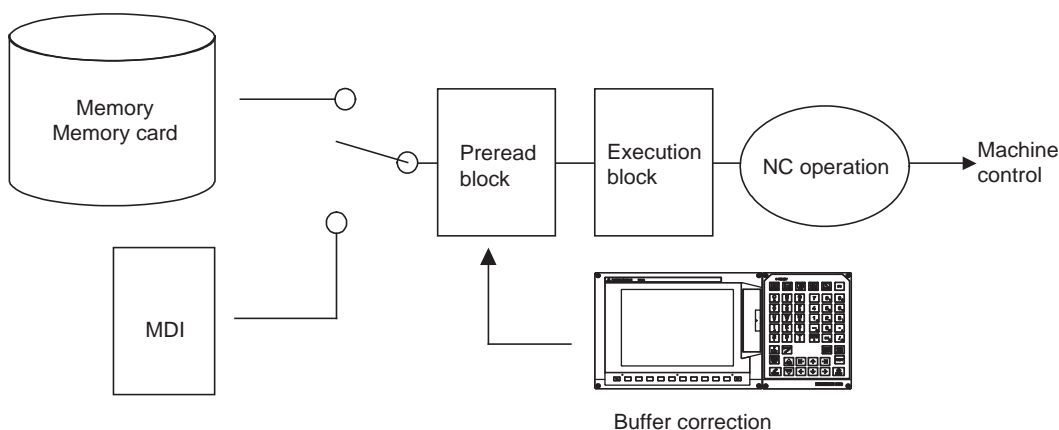
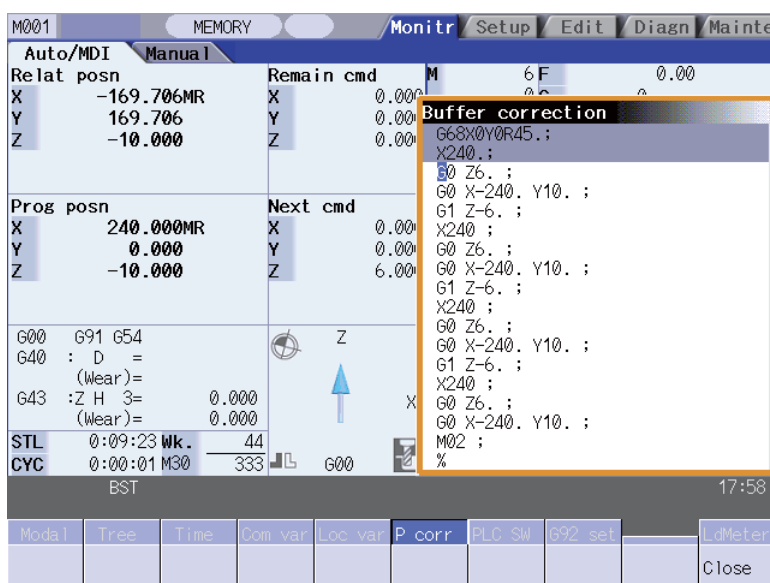

- (1) The next command can be corrected in the following two cases.
 - When single block stop is applied, and there is a command block to be corrected in the next command.
 - When there is an error (program error) in the next command and automatic operation is stopped.
- (2) Not only the displayed buffer data but also the contents in the device are corrected with the buffer corrections. (The corrected data is reflected.)
- (3) Several blocks following the next command can be corrected simultaneously.

Menus

Menu	Details	Type	Reference
Close	This closes the pop-up window and quits this function.	C	

Operation method

During a single block stop or when a program error stop occurs, the buffer can be corrected with the following operations, and operation can be continued.

The normally executed program appears in the buffer correction area.

<pre>N121 G28 X10.Y10.; N122 T1212; N123 S1230 M3; N124 G00 X68. Z201.; N125 G01 X80. Z195. F50; N126 Z150.; N127 G02 X100. Z185. R20;</pre>	<p>← Previous command</p> <p>← Command in execution</p> <p>← Next command and subsequent commands</p>
--	---

(1) Press the main menu [Prg correct].



The buffer correction mode is entered.

<pre>N121 G28 X10.Y10.; N122 T1212; N123 S1230 M3; N124 G00 X68. Z201.; N125 G01 X80. Z195. F50; N126 Z150.; N127 G02 X100. Z185. R20;</pre>	<p>← Next command and subsequent commands</p>
--	---

The display changes so that the next command is at the head of the area. The buffer correction area becomes the valid area, and the keys can be input or the cursor moved. The cursor can be moved freely within the buffer correction area using the cursor keys.

(2) Correct the program with the same method as a normal program editing.

(3) Press the [INPUT] key.



The buffer correction mode ends, and the corrected data is written into program. If a program error has occurred, the error display is erased.

(4) Confirm that the corrected data is correct, and then restart.



The program execution resumes from the currently stopped position.

Precautions

- (1) Buffer correction mode will not be applied in the following cases.
 - (a) Machining program for buffer corrections is in edit lock or program display lock state.
 - (b) Data protection key 3 is enabled.
 - (c) Machining program for the device in write-protection state
 - (d) Machining program in read-only state
 - (e) During the compound type fixed cycle, the tool center point control or executing the machine tool builder macro program
- (2) Starting and ending buffer corrections
 - (a) If automatic operation is started or there is no next command data, the buffer correction mode is not entered even if the menu key is pressed.
 - (b) To stop or to cancel the buffer corrections, press the menu [Close] again, or press the  key.
 - (c) If another menu key, etc., is pressed before pressing the [INPUT] key, the corrected buffer contents return to the original data.
 - (d) If changing to another screen or resetting the NC during buffer correction, the buffer correction is canceled. In this case, the corrected contents are not saved, and the buffer correction mode ends.
- (3) Display data during buffer correction
 - (a) The key operations used for corrections in the buffer correction mode are the same as the operations when editing a program. Up to 16 blocks can be displayed. Even when a block is displayed over several lines, all 16 blocks can be displayed by scrolling the buffer correction area.
 - (b) Number of characters in one block is max. 256. If exceeds 256 characters, the block will be split into two.
 - (c) Up to 4096 characters can be edited with buffer corrections.
- (4) Operations during buffer correction
 - (a) If there is no ";" (EOB) at the data in the last block corrected when the [INPUT] key is pressed, it is added automatically.
 - (b) When the buffer correction mode is entered, the last block displayed in the buffer correction area may not fit in if the block is long, etc.

To correct this type of block, take care to the following points.

 - If a ";" (EOB) is added to the end of the displayed data, the section following the incomplete display becomes another block. If ";" (EOB) is not added, the following section stays the same, and is handled as the continuation of the displayed section.
 - If one block is deleted by pressing the [C.B] key, the block is deleted up to the section following the incomplete display (up to the ";").
 - (c) Operation cannot be started during buffer correction. An alarm occurs.
 - (d) If NC is reset during buffer correction, buffer correction mode will be canceled, although buffer correction window is left opened. At this time, editing operation is not possible. Close the correction window.
 - (e) Buffer correction writing is not interrupted by NC reset.
 - (f) The operation message "Can't write into file" appears at any attempt of the buffer mode correction to write into the program being operated or checked, which had stopped when the buffer correction mode started.

(5) Previous command and command in execution

- (a) When the buffer is corrected following the operation mode change at single block stop, nothing will be displayed in previous command and command in execution.
- (b) When there is no block after sub program call or user macro call, a program error occurs at the last block of the destination program. If a buffer correction is made in this state, the destination program will be displayed in the buffer correction window, but the actual correction result will be reflected on the source program.
- (c) The buffer cannot be corrected when the block where the buffer is corrected is in the forward side from the block called at another nest level. The operation message "Buffer correct not possible" appears. The buffer can be corrected when the block where the buffer is corrected is in the rear side from the block called at another nest level.

- (a) : The buffer can be corrected.
- (b)(d) : The buffer can be corrected because the block is in the rear side from (a).
- (c) : The buffer cannot be corrected because the block is in the forward side from (b).

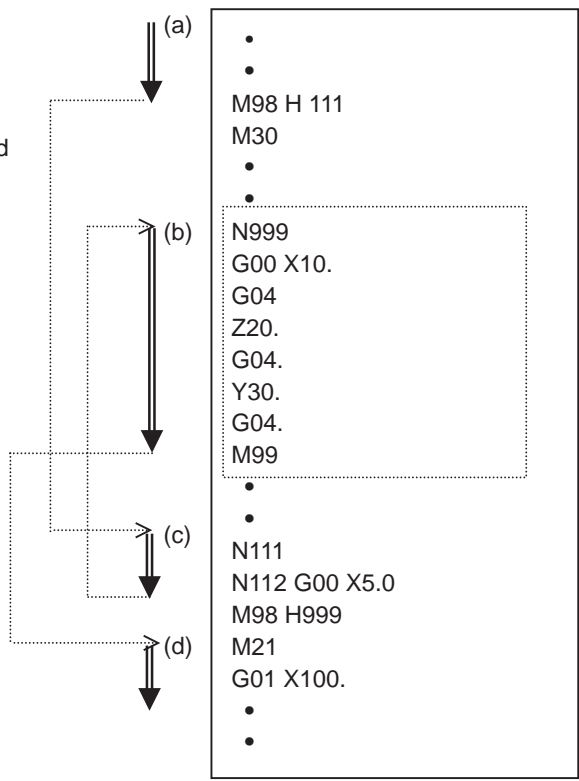



2.19 PLC Switch Function

The various control signals for NC operation can be turned ON and OFF.
Refer to the instruction manual issued by the machine tool builder for details.

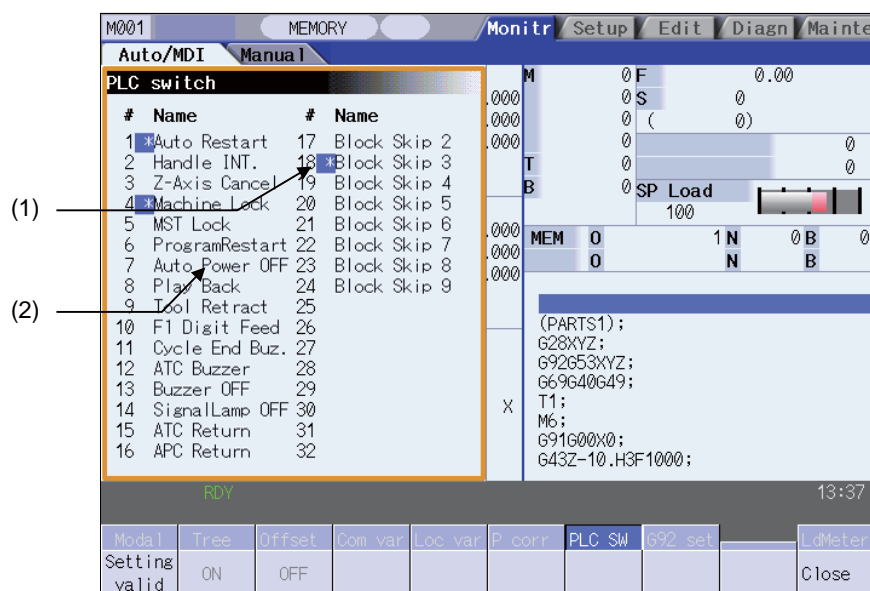

Display items

Display item	Details
(1) Mark indicating switch ON	This is displayed for switches that are turned ON
(2) Switch name	The display contents differ depending on machine tool builder specification.

Menus

Menu	Details	Type	Reference
Setting valid	Setting of the PLC switch is started.	A	2.20.1 Turning PLC Switches ON/OFF
ON	This turns ON the switch currently indicated by the cursor.	C	
OFF	This turns OFF the switch currently indicated by the cursor.	C	
Close	This closes the pop-up window and quits this function.	C	

2.19.1 Turning PLC Switches ON/OFF

Operation method (To turn switch "#6 Program restart" ON)

- (1) Press the menu [Setting valid] . The menu Setting valid will be highlighted.
A message confirming the start of PLC switch setting will appear.
- (2) Press "Y" or [INPUT] The PLC switch setting mode will be entered.
The cursor will appear at the PLC switch No. position. The menu keys [ON] and [OFF] will appear normally.
- (3) Press the cursor keys [↑] and [↓] to move the cursor to "#6". The #6 number is highlighted.

#	Name
1	*Auto Restart
2	Handle INT.
3	Z-Axis Cancel
4	*Machine Lock
5	MST Lock
6	ProgramRestart
7	Auto Power OFF

- (4) Press the menu key [ON] . The "#6 Program restart" switch turns ON, and a [*] mark appears.

#	Name
1	*Auto Restart
2	Handle INT.
3	Z-Axis Cancel
4	*Machine Lock
5	MST Lock
6	*ProgramRestart
7	Auto Power OFF

To turn OFF, press the menu key OFF.

a [*] mark appears.

- (Note 1) If the [Setting valid] menu or key is pressed again during the PLC switch setting mode, the PLC switch setting mode will be canceled.
- (Note 2) The PLC switch setting mode is canceled when the PLC switch's pop-up window is closed.
- (Note 3) The cursor will not appear in modes other than the PLC switch setting mode.



2.20 Load Meter Display

The spindle load and Z axis load, etc., are displayed.

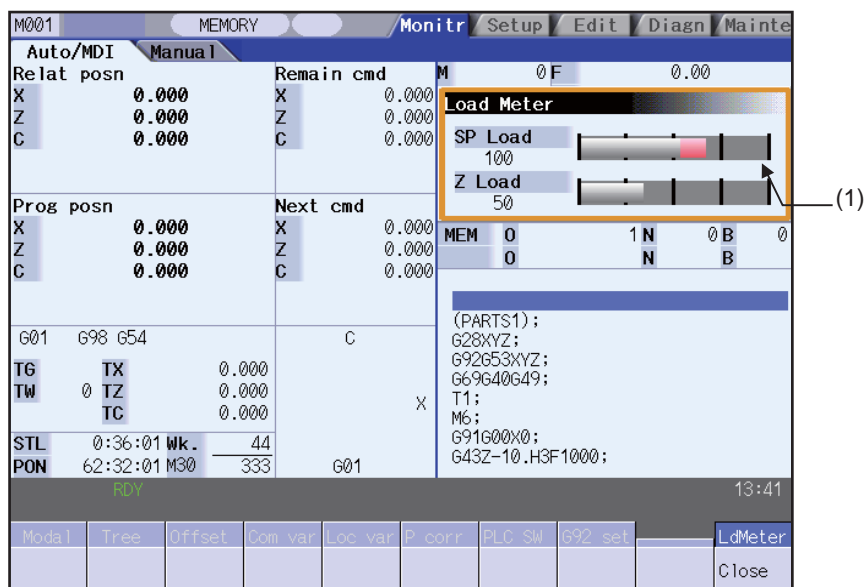

Display items

Display item	Details
(1) Load meter 1	The spindle load and Z axis load, etc., are displayed in a bar graph.
Load meter 2	These displayed contents differ according to the machine tool builder.

Menus

Menu	Details	Type	Reference
Close	This closes the pop-up window and quits this function.	C	

(Note1) Due to the specifications issued by machine tool builder, pressing [Load meter] menu without setting ON load meter display causes an error.

2.21 Spindle, Standby Display



The current spindle tool No. and the standby tool No. are displayed.

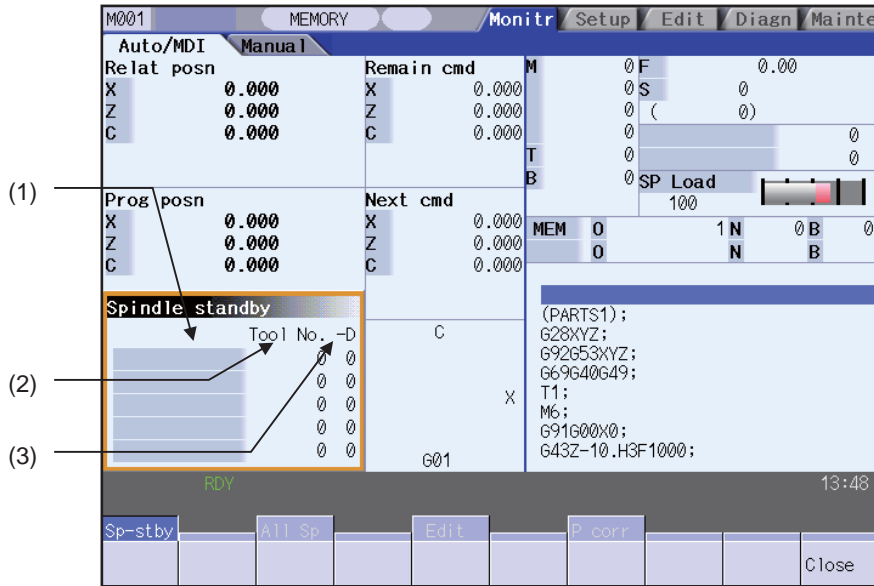

Display items

Display item	Details
(1) Spindle standby	The display contents differ depending on machine tool builder specification.
(2) Tool No.	This displays No. of tool that is attached to the spindle or standby position in the magazine 1
(3) -D	For D data function and purpose, refer to the parts instruction manual issued by the machine tool builder.

Menus

Menu	Details	Type	Reference
Close	This closes the pop-up window and quits this function.	C	



2.22 All Spindles' Rotation Speed Display

The current spindle tool No. and the standby tool No. are displayed.
This function only displays the value. It is not possible to operate here.

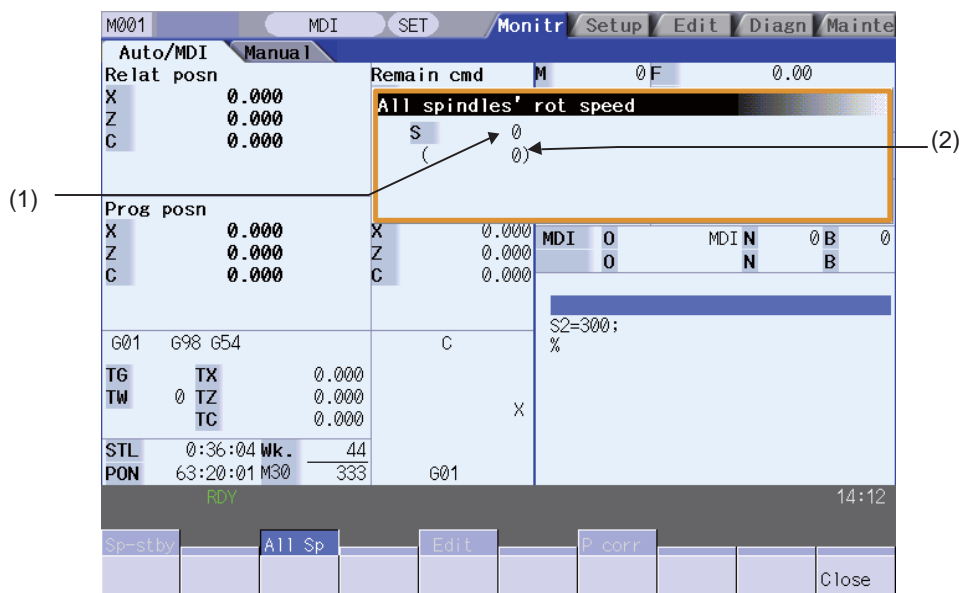

Display items

Display item	Details
(1) Spindles' command rotation speed	This displays the spindles' command rotation speed (S command value).
(2) Spindles' actual rotation speed	This displays the spindles' actual rotation speed (r/min).

Menus

Menu	Details	Type	Reference
Close	This closes the pop-up window and quits this function.	C	





Setup Screens

The setup screen is used to make tool and workpiece related settings, set user parameters, edit the MDI, set the counter, and perform manual numerical value commands.

3.1 Screen Configuration



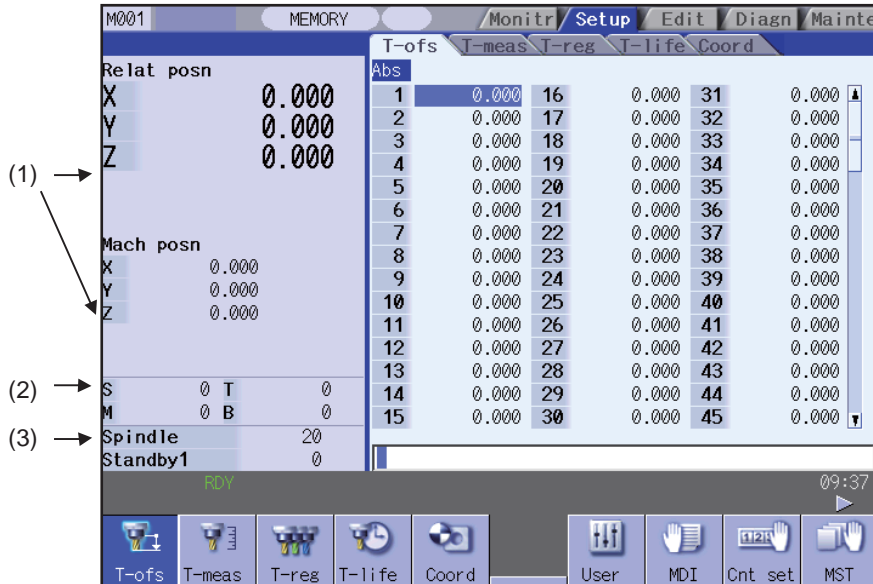







The setup screen is configured as shown below.



Display items

Display item	Details
(1) Counter display	<p>This displays the relative position and machine position counter. Up to 5 axes can be simultaneously displayed.</p> <p>The following status symbols display if each of the axes are in a set position or status. #1 to 4: Reference position 1 to 4 [J]: Servo OFF status MR: Mirror image ><: Axis removed CT: Auxiliary axis state</p> <p>It is possible to set whether to consider the tool length and diameter compensation using parameter "#1287 ext23/bit4".</p> <p>Whether to display the axis counter is set by the parameter "#1069 no_dsp".</p>
(2) M,S,T,B Command	<p>This displays all command values for M (support function command value), S (spindle command rotation speed), T (tool command value) and B (2nd miscellaneous function command value). The spindle command rotation speed displays only 1st spindle.</p> <p>The presence (absence) of the 2nd miscellaneous function command value is designated using parameter "#1170 M2name".</p> <p>Refer to "3.11 Manual Numerical Value Commands" for details.</p>
(3) Spindle/Wait display	<p>The current spindle tool number and standby tool number can be displayed according to the PLC program specifications. (The numbers do not display in the screen if not created with the PLC program.)</p> <p>The contents of this display differ based on the machine tool builder specifications.</p>

Menus

Menu	Details	Reference
 Offset	This sets the tool compensation amount. There are three types of tool compensation, and the display differs for each type. The number of tool compensation combinations are 200 sets on M system and 80 sets on L system.	3.2 Tool Compensation amount
 T-meas	This performs the tool measurement. By manually moving the tool to the measurement point, the movement distance from the basic point to the measurement point is measured, and this can be set as the tool compensation amount. This menu is displayed when "#8932 Hide measure scrn" is set to "0".	3.3 Tool Measurement
 T-reg	This registers tools. A tool number is allocated to the tool to allow the NC to recognize the tool attached to the machine. The tool number is registered based on the magazine pot, spindle, and standby location to which the tool is attached.	3.4 Tool Registration
 T-life	This performs the tool life management. The life management data containing information such as the tool usage status is set and displayed. Two management methods are used for tool life management.	3.5 Tool Life Management
 Coord	This sets the workpiece coordinate system offset amount. This sets and displays the coordinate system offset amount controlled by the NC.	3.6 Workpiece Coordinate System Offset
 User	This sets the user parameters. This screen is used to switch between, set, and display parameter types.	3.8 User Parameters
 MDI	This edits the MDI program. Press this menu to show the MDI program contents in a pop-up display.	3.9 MDI Program Editing
 Cnt set	This sets an arbitrary value for the relative position counter.	3.10 Counter Setting
 MST	This performs the manual numerical value commands.	3.11 Manual Numerical Value Commands
 T-list	This searches T code among the designated program (including the subprograms) and lists in order that it was found.	3.12 T Code List

3.2 Tool Compensation Amount



The tool compensation data can be set and displayed.

The tool compensation data screen configuration differs according to the tool compensation type.

Tool compensation combinations are 200 sets on M system and 80 sets on L system.

Inputting an address key, such as MST, displays manual numerical value command window where manual numerical value command is executed.

(Note) When the tool compensation amount setting during automatic operation is enabled ("#11017 T-ofs set at run" = "1"), the tool compensation amount data can be set even during automatic operation or operation pause.

3.2.1 Tool Compensation Amount (M system)

[Tool compensation type I] : Parameter "#1037 cmdtyp" = 1

The combined amount of the shape compensation and wear compensation are set as the compensation data, with no distinction between shape compensation memory and wear compensation memory. (The tool compensation data is the shape compensation amount + wear compensation amount.)

The compensation data is used commonly for the tool length compensation, tool position offset, and tool radius compensation.

Relat posn		T-ofs					
		Abs	T-meas	T-reg	T-life	Coord	
X	0.000	1	0.000	16	0.000	31	0.000
Y	0.000	2	0.000	17	0.000	32	0.000
Z	0.000	3	0.000	18	0.000	33	0.000
		4	0.000	19	0.000	34	0.000
		5	0.000	20	0.000	35	0.000
		6	0.000	21	0.000	36	0.000
		7	0.000	22	0.000	37	0.000
		8	0.000	23	0.000	38	0.000
		9	0.000	24	0.000	39	0.000
		10	0.000	25	0.000	40	0.000
		11	0.000	26	0.000	41	0.000
		12	0.000	27	0.000	42	0.000
		13	0.000	28	0.000	43	0.000
		14	0.000	29	0.000	44	0.000
		15	0.000	30	0.000	45	0.000

When "#11050 T-ofs digit type" is set to "0", up to 3 digits can be set in the integer part.
When "#11050 T-ofs digit type" is set to "1", up to 4 digits can be set in the integer part.

[Tool compensation type II] : Parameter "#1037 cmdtyp" = 2

The shape compensation amount and wear compensation amount are set separately. The shape compensation amount is furthermore divided into length and radius dimensions.

Of the compensation data, the length dimension data is used for the tool length compensation and tool position offset, and the radius dimension data is used for the tool radius compensation.

Relat posn		T-ofs				
		Abs	Length	L wear	Radius	R wear
X	0.000	1	0.000	0.000	10.000	0.000
Y	0.000	2	0.000	0.000	0.000	0.000
Z	0.000	3	0.000	0.000	0.000	0.000
		4	0.000	0.000	0.000	0.000
		5	0.000	0.000	0.000	0.000
		6	0.000	0.000	0.000	0.000
		7	0.000	0.000	0.000	0.000
		8	0.000	0.000	0.000	0.000
		9	0.000	0.000	0.000	0.000
		10	0.000	0.000	0.000	0.000
		11	0.000	0.000	0.000	0.000
		12	0.000	0.000	0.000	0.000
		13	0.000	0.000	0.000	0.000
		14	0.000	0.000	0.000	0.000
		15	0.000	0.000	0.000	0.000

When "#11050 T-ofs digit type" is set to "0", up to 3 digits can be set in the integer part.
When "#11050 T-ofs digit type" is set to "1", up to 4 digits can be set in the integer part. The display is switched between length/radius dimensions and length/radius wears using the menus [lg/rad dim] and [lg/rad wear].

⚠ CAUTION

⚠ If the tool compensation amount or workpiece coordinate system offset amount is changed during automatic operation (including during single block stop), the changes will be valid from the command in the next block or after several subsequent blocks.

Display items

Display item	Details
(1) Display area	<p>Displays the tool compensation data. The displayed cursor can be moved and data set. Data that cannot be displayed in the display area can be displayed using the keys below.</p> <p>↑ , ↓ : Scroll one line at a time.</p> <p>▲ , ▼ : Change the display contents one page at a time.</p> <p>Compensation number: This is the compensation data number.</p> <p>Compensation data: The display items differ depending on the tool compensation type.</p> <p>[Type I] Compensation data: Amount in which the shape and wear compensations are combined</p> <p>[Type II] Length dimension: Tool length compensation amount. Length wear: Tool length wear compensation amount. Radius dimension: Tool radius compensation amount. Radius wear: Tool radius wear compensation amount.</p> <p>The setting/display range is different depending on the combination of the settings of "#1003 iunit" and "#1041 I_inch". (Note 1) (Note2)</p>

(Note 1) The setting/display ranges are as follows based on the "#1003 iunit(Input unit)", "#1041 I_inch(Initial state (inch))", and #11050 T-ofs digit type (Tool compensation digit type) setting combination.

#1003 iunit	#1041 I_inch	#11050 T-ofs digit type	Setting/display range
B	0	0	-999.999 to 999.999
		1	-9999.999 to 9999.999
	1	0	- 99.9999 to 99.9999
		1	- 999.9999 to 999.9999
C	0	0	-999.9999 to 999.9999
		1	-9999.9999 to 9999.9999
	1	0	- 99.99999 to 99.99999
		1	- 999.99999 to 999.99999

When data without the decimal point is input, a set unit can be specified by the parameter "#8119 Comp. unit switch".

(Note2) The standard settings and display ranges are as follows.

Type	Settings	Details	Setting/display range
I	Compensation data	This sets the shape and wear combined compensation amounts.	-999.999 to 999.999
II	Length dimension	This sets the tool length compensation amount.	-999.999 to 999.999
	Length wear	This sets the tool length wear compensation amount.	
	Radius dimension	This sets the tool radius compensation amount.	
	Radius wear	This sets the tool radius wear compensation amount.	

The display range is when the minimum command unit is 1 μm ("#1003 iunit"= B, "#1041 I_inch" = 0, "#11050 T-ofs digit type" = 0).

Menus

Menu	Details	Type	Reference
=Input	This executes an absolute input. When "#8929 Disable=INPUT : comp" is set to "1", this menu cannot be selected.	C	3.2.1.1 Setting the Tool Compensation Data
+Input	This executes an addition input.	C	
Offset No.	Set the compensation number and press [INPUT] to put that number to the top and display the tool compensation data. The cursor moves to the contents of that first line.	A	3.2.1.1 Setting the Tool Compensation Data
Line copy	This copies the contents of the tool compensation data in the selected line (one line).	C	3.2.1.4 Copying/ Pasting the Tool Compensation Data
Line paste	The contents (one line) of the copied tool compensation data are written to the line where the cursor is. If changes are made to the data in that line after [Line copy] is selected from the menu, the data prior to the changes is written when pasting. The data in the copied line can be pasted as many times as is required until new data is copied.	C	
Line clear	This erases the compensation data in the selected line (multiple lines can be erased). Selection method: Select the first and the last compensation number to be erased. [Ex.] 1/E: Set all compensation data to "0". If the [INPUT] key is pressed without selecting a line, the compensation data in the line where the cursor is currently positioned is erased.	A	3.2.1.3 Erasing the Tool Compensation Data
Undo	This undoes the last changes to the tool compensation data. (This menu is valid for the "Data Input", "Paste Line" and "Undo" operations.) (Note) When an operation parameter "#8939 Undo confirm msg" is set to "1", the menu is highlighted while the operation message is displayed.	C/A	
Abs/Inc	Switch the setting method (absolute/addition input) for the tool compensation data by [INPUT] key. (Note) When a parameter "#8941 ABS/INC for T-ofs" is set to "0", it is fixed to an absolute input.	C	3.2.1.2 Switching the Input Method for the Tool Compensation Data

3.2.1.1 Setting the Tool Compensation Data

Operation method (Setting "37.000" in the length wear data of compensation No. (102))

(1) Press the menu key [Offset No.]

(2) Designate the Compensation No.
102 [INPUT]

➔ The set number appears at the top of the area, and the cursor moves.

It is possible to use the [↑], [↓], [⬆] and [⬇] keys as well to move the cursor to the offset No.102.

	Length	L wear	Radius	R wear
102	0.000	0.000	0.000	0.000
103	0.000	0.000	0.000	0.000
104	0.000	0.000	0.000	0.000
105	0.000	0.000	0.000	0.000
106	0.000	0.000	0.000	0.000
107	0.000	0.000	0.000	0.000
108	0.000	0.000	0.000	0.000

(3) Use the [→] key to move the cursor to the length wear position.

(4) Input the length wear value.
37.000 [INPUT]

➔ The set value displays.

Settings can be made by pressing the [=INPUT] key instead of the [INPUT]key.

Tool offset data setting example

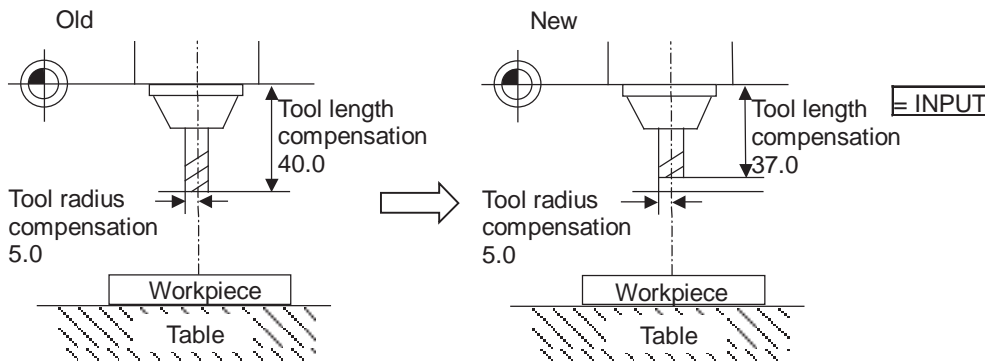

Operation method (" -3.000" is calculated and set in the length wear data for compensation number (102).)

Use the same procedure as (1) above to move the cursor to the compensation No. 102 length wear position.

(2) Enter a value.

-3.000 [+INPUT]



The input value is added to the original value and displays.

[Ex.] 37.000 displays if the original value is 40.000. (40.000 - 3.000 = 37.000)

Tool offset data setting example

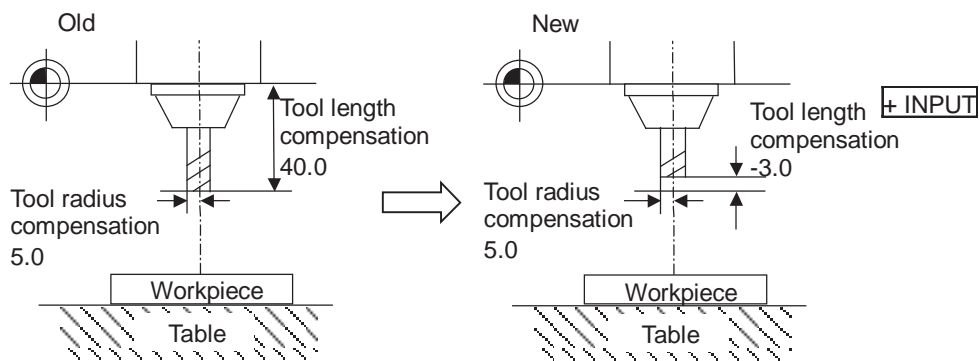

3.2.1.2 Switching the Input Method for the Tool Compensation Data

When a parameter "#8941 ABS/INC for T-ofs" is set to "1", the absolute/addition input by the [INPUT] key can be switched. When attempting to switch it, the current input mode is displayed on the upper left of the tool compensation amount. The absolute/addition input can be switched either by the short cut key ([I] key) or by pressing the [Abs/Inc] key in the menu. The chosen method is kept after switching the screen and turning the power OFF.

(1) Absolute input mode

In this mode, the absolute input is applied when the tool compensation data is input by the [INPUT] key.

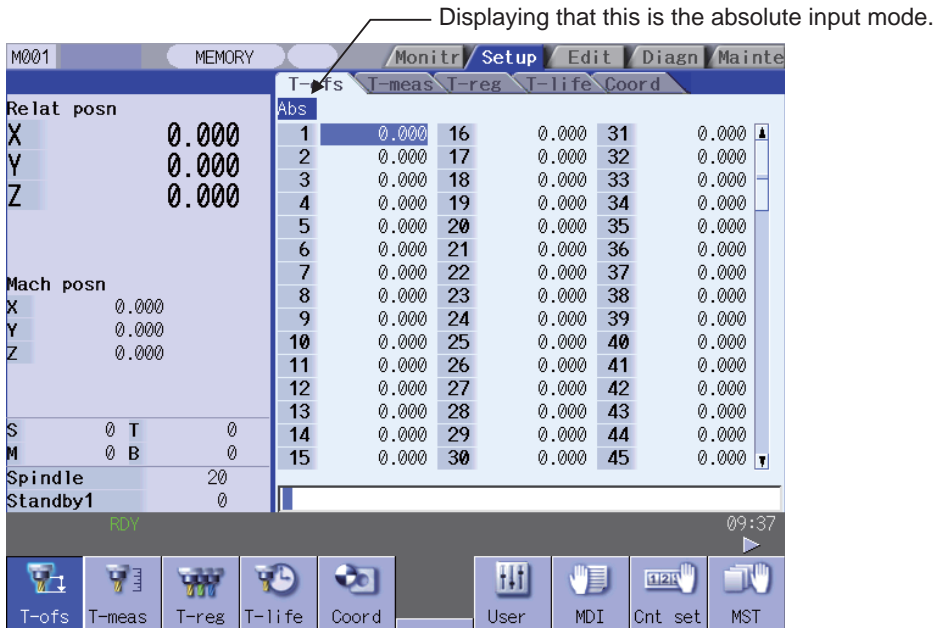

(2) Addition input mode

In this mode, the addition input is applied when the tool compensation data is input by the [INPUT] key.

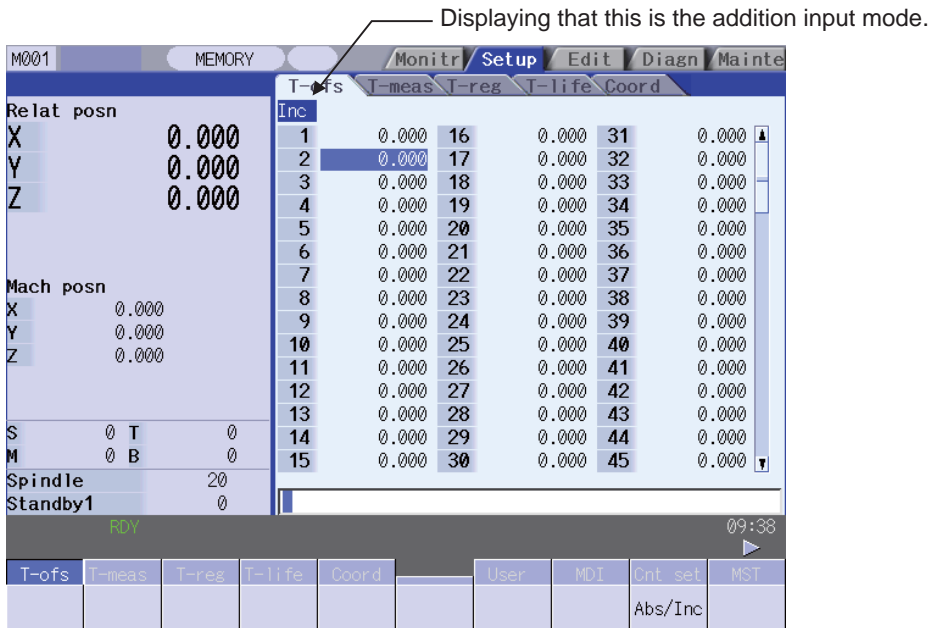

3.2.1.3 Erasing the Tool Compensation Data

Operation method (Erasing one line of tool compensation data at the cursor position)

- (1) Move the cursor to the line to be erased with the [↑],
[↓], [↑] and [↓] keys.

➔ The cursor appears at the data item of the selected compensation No.

	Length	L wear	Radius	R wear
101	0.000	0.000	0.000	0.000
102	230.630	10.000	42.140	8.000
103	-280.028	0.000	10.000	0.000
104	-272.083	0.000	0.000	0.000
105	-220.068	0.000	12.000	0.000
106	-290.456	0.000	8.000	0.000
107	-280.001	0.000	0.000	0.000

- (2) Press the [Line clear] and [INPUT] menu.

➔ The menu keys are highlighted and a message displays confirming whether it is okay to erase.
The background color of the data to be erased displays in light blue.

- (3) Press the [Y] or [INPUT] key.

➔ The selected line of data (one line amount) is cleared to zero.
The data erased to zero displays at the top of the compensation data.

	Length	L wear	Radius	R wear
102	0.000	0.000	0.000	0.000
103	-280.028	0.000	10.000	0.000
104	-272.083	0.000	0.000	0.000
105	-220.068	0.000	12.000	0.000
106	-290.456	0.000	8.000	0.000
107	-280.001	0.000	0.000	0.000
108	0.000	0.000	0.000	0.000

To cancel the erasing, press a key other than [Y] or [INPUT].

Operation method (Erasing the compensation data from compensation number 122 to 125.)

- (1) Press the [Line clear] menu.

➔ The menu is highlighted.

- (2) Input the compensation number of the data range to be erased.
122/125 [INPUT]

➔ A message box displays to confirm whether it is okay to erase the data.
The background color of the data to be erased displays in light blue.

- (3) Press the [Y] or [INPUT] key.

➔ The compensation data for the selected compensation number is erased, and the menu highlight returns to normal.
The data cleared to zero displays at the top of the compensation data.

	Length	L wear	Radius	R wear
122	0.000	0.000	0.000	0.000
123	0.000	0.000	0.000	0.000
124	0.000	0.000	0.000	0.000
125	0.000	0.000	0.000	0.000
126	-220.068	0.000	12.000	0.000
127	-290.456	0.000	8.000	0.000
128	-280.001	0.000	0.000	0.000

Press a key other than [Y] or [INPUT] in order not to erase the data.

(Note) If the [INPUT] key is pressed without selecting an compensation number, the line where the cursor is located is erased.

3.2.1.4 Copying/Pasting the Tool Compensation Data

Operation method (Copying/pasting one line of tool compensation data)

- (1) Move the cursor to the line to be copied with the [↑], [↓], [▲] and [▼] keys.

- (2) Press the [Line copy] menu. ➔ The background color of the copied data changes to light blue.

	Length	L wear	Radius	R wear
100	0.000	0.000	0.000	0.000
101	-255.123	0.000	0.000	0.000
102	-250.008	0.000	10.000	0.000
103	-280.028	0.000	10.000	0.000
104	-272.083	0.000	0.000	0.000
105	-220.068	0.000	12.000	0.000
106	-290.456	0.000	8.000	0.000

- (3) Move the cursor to the line (compensation No.: 109) where the data is to be pasted.

- (4) Press the [Line paste] menu. ➔ The copied compensation data is written in the line where the cursor is.
The background color returns to normal.
The copied compensation data is held until another line is copied.

	Length	L wear	Radius	R wear
105	-220.068	0.000	12.000	0.000
106	-290.456	0.000	8.000	0.000
107	-280.001	0.000	0.000	0.000
108	0.000	0.000	0.000	0.000
109	-250.008	0.000	10.000	0.000
110	0.000	0.000	0.000	0.000
111	0.000	0.000	0.000	0.000

(Note 1) If the compensation data for the copied line is changed after the menu [Line copy] is pressed, the data prior to the change is written when pasted.





3.2.1.5 Disabling the setting of tool compensation amount

Depending on the setting of the parameter "#8933 Disable lngth comp"/"#8934 Disable wear comp", the setting of the shape compensation amount/wear compensation amount is disabled.

Depending on the tool compensation type, different operation will be disabled.

Tool compensation type	"#8933 Disable lngth comp"=1	"#8934 Disable wear comp"=1
Type I	- Setting with the [INPUT] key is disabled. - The following menu cannot be selected. [= Input], [+ Input], [Line copy], [Line paste], [Line clear], [Undo]	----
Type II	- Setting of the length dimension and radius dimension with the [= Input], [+ Input] menus, and [INPUT] key is disabled. - The following menu cannot be selected. [Line copy], [Line paste], [Line clear]	- Setting of the length wear and radius wear with the [= Input], [+ Input] menus, and [INPUT] key is disabled. - The following menu cannot be selected. [Line copy], [Line paste], [Line clear]

Display items

Display item	Details
(1) Display area	<p>Displays the tool compensation data. The displayed cursor can be moved and data set. Data that cannot be displayed in the display area can be displayed using the keys below.</p> <p>  ,  : Scroll one line at a time.  ,  : Change the display contents one page at a time. </p> <p>Compensation number: This is the compensation data number.</p> <p>Compensation data: This displays the tool nose wear compensation amount of 1st axis, 2nd axis and additional axis.</p> <p>Set whether to set the additional axis tool nose wear compensation amount for 3rd or 4th axis at parameter "#1520 Tch34".</p> <p>Displays only for the number of valid axes if only 1st axis or 2nd axis are valid.</p> <p>The setting/display range is different depending on the combination of the settings of "#1003 iunit" and "#1041 I_inch". (Note 1)</p> <p>The standard settings and display ranges are -9999.999 to 9999.999.(The display range is when the minimum command unit is 1 μm ("#1003 iunit"= B, "#1041 I_inch"= 0).</p> <p>In addition, depending on the settings of parameter "#8010 ABS. MAX." and "#8011 INC. MAX.", the setting/display range may be different from the above.</p>

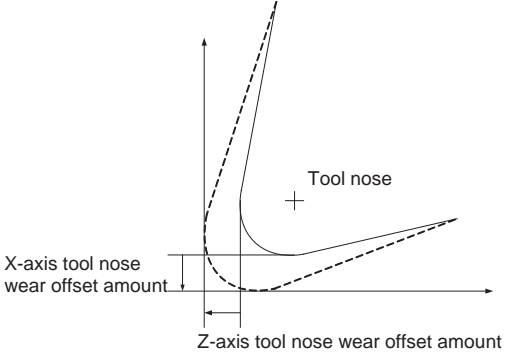
	<p>X axis offset X axis tool length offset +X axis wear offset</p> <p>Z axis offset Z axis tool length offset +Z axis wear offset</p> <p>Y axis offset (additional axis) Y axis tool length offset +Y axis wear offset</p>
--	--

(Note 1) The setting and display ranges are as follows based on the "#1003 iunit" and "#1041 I_inch" setting combination.

#1003 iunit	#1041 I_inch	Setting/display range
B	0	-9999.999 to 9999.999
	1	- 999.9999 to 999.9999
C	0	-9999.9999 to 9999.9999
	1	- 999.99999 to 999.99999

When data without the decimal point is input, a set unit can be specified by the parameter "#8119 Comp. unit switch".

Menus

Menu	Details	Type	Reference
=Input	This executes an absolute input.	C	3.2.2.4 Operation Method
+Input	This executes an addition input.	C	(1) Setting the Tool Compensation Data
Wear data	This changes to the wear data display. (Note) This menu displays for Type III.	B	
Length data	This changes to the tool length data display. (Note) This menu displays for Type III.	B	
Nose data	This changes to the tool nose data display. (Note) This menu displays for Type III.	B	
Offset No.	Set the compensation number and press [INPUT] to put that number to the top and display the tool compensation data. The cursor moves to the contents of that first line.	A	3.2.2.4 Operation Method (1) Setting the Tool Compensation Data
Line copy	This copies the contents of the tool compensation data in the selected line (one line).	C	3.2.2.4 Operation Method
Line paste	The contents (one line) of the copied tool compensation data are written to the line where the cursor is. If changes are made to the data in that line after [Line copy] is selected from the menu, the data prior to the changes is written when pasting. The data in the copied line can be pasted as many times as is required until new data is copied.	C	(3) Copying/Pasting the Tool Compensation Data
Line clear	This erases the compensation data in the selected line (multiple lines can be erased). Selection method: Select the first and the last compensation number to be erased. [Ex.] 1/E: Set all compensation data to "0". If the [INPUT] key is pressed without selecting a line, the compensation data in the line where the cursor is currently positioned is erased.	A	3.2.2.4 Operation Method (2) Erasing the Tool Compensation Data
Undo	This undoes the last changes to the tool compensation data. (This menu is valid for the "Data Input", "Paste Line" and "Undo" operations. A line clear operation cannot be undone.) (Note) When the operation parameter "#8939 Undo confirm msg" is set to "1", the menu is highlighted while the operation message is displayed.	C/A	
Abs/Inc	Switch the setting method (absolute/addition input) for the tool compensation data by [INPUT] key. (Note) When a parameter "#8941 ABS/INC for T-ofs" is set to "0", it is fixed to an absolute input.	C	3.2.1.2 Switching the Input Method for the Tool Compensation Data

The wear data displays when the power is turned ON.

Following that, the wear data, tool length data, and tool nose data selection is stored.

3.2.2.2 Tool Length Data

Set the tool length in respect to the program basic position of each tool used. When the tool compensation No. is designated by the tool command (T command), compensation is carried out matching the wear data and the tool nose data.

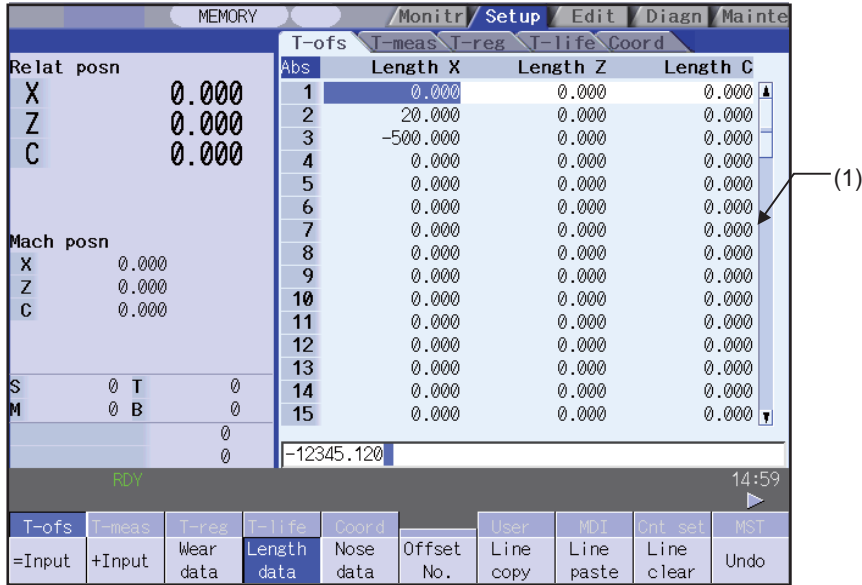

⚠ CAUTION

⚠ If the tool compensation amount or workpiece coordinate system offset amount is changed during automatic operation (including during single block stop), the changes will be valid from the command in the next block or after several subsequent blocks.

Display items

Display item	Details
(1) Display area	<p>Displays the tool compensation data. The displayed cursor can be moved and data set. Data that cannot be displayed in the display area can be displayed using the keys below.</p> <p> , : Scroll one line at a time. , : Change the display contents one page at a time. </p> <p>Compensation number: This is the compensation data number.</p> <p>Compensation data: This displays the tool length compensation amount of 1st axis, 2nd axis and additional axis.</p> <p>Set whether to set the additional axis tool nose wear compensation amount for 3rd or 4th axis at parameter "#1520 Tch34".</p> <p>Displays only for the number of valid axes if only 1st axis or 2nd axis are valid.</p> <p>The setting/display range is different depending on the combination of the settings of "#1003 iunit" and "#1041 l_inch". (Note 1)</p> <p>The standard settings and display ranges are -9999.999 to 9999.999.(The display range is when the minimum command unit is 1 μm ("#1003 iunit")B, "#1041 l_inch" = 0).</p>

(Note 1) The display and setting ranges are as follows based on the "#1003 iunit" and "#1041 l_inch" setting combination.

#1003 iunit	#1041 l_inch	Setting/display range
B	0	-9999.999 to 9999.999
	1	- 999.9999 to 999.9999
C	0	-9999.9999 to 9999.9999
	1	- 999.99999 to 999.99999

When data without the decimal point is input, a set unit can be specified by the parameter "#8119 Comp. unit switch".

Generally, the center of the tool rest or the tip of the base tool is used as the programmed base position.

(1) The programmed base position is the center of the tool rest:

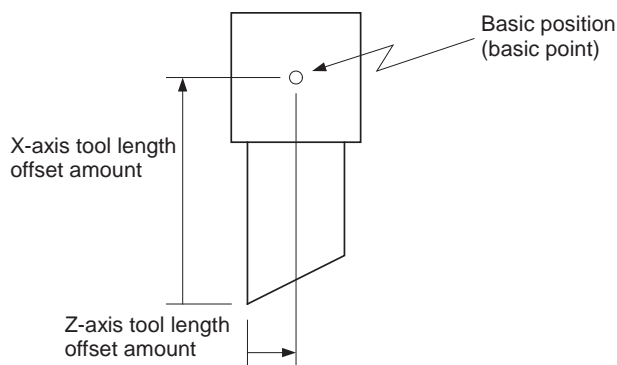

(2) The programmed base position is the tip of the base tool:

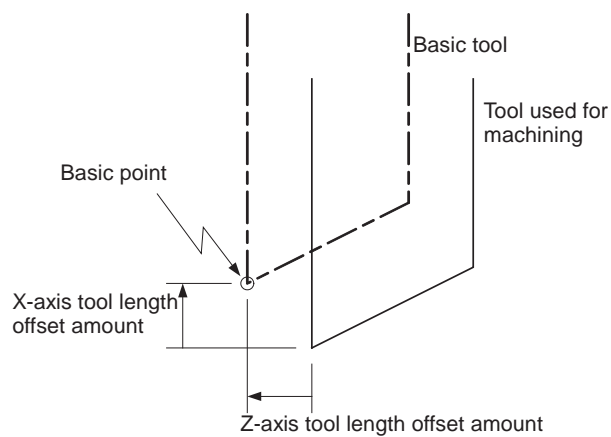

Menus

Same as "3.2.2.1 Wear Data".

3.2.2.3 Tool Nose Data

Set the tool nose radius value (tool nose R), wear radius value (R wear) and tool nose point (tool nose point P) of the tool nose mounted on the tool for each tool used. When the tool compensation No. is designated by the tool command (T command), compensation is carried out matching the tool length data and tool nose data.

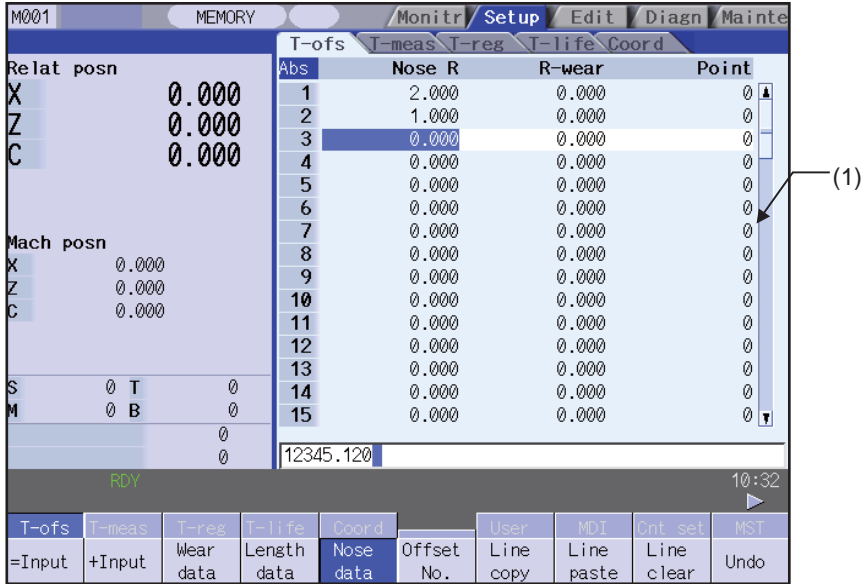

CAUTION

If the tool compensation amount or workpiece coordinate system offset amount is changed during automatic operation (including during single block stop), the changes will be valid from the command in the next block or after several subsequent blocks.

Display items

Display item	Details
(1) Display area	<p>Displays the tool compensation data. The displayed cursor can be moved and data set. Data that cannot be displayed in the display area can be displayed using the keys below.</p> <p>↑, ↓: Scroll one line at a time.</p> <p>⬆, ⬇: Change the display contents one page at a time.</p> <p>Compensation number: This is the compensation data number.</p> <p>Compensation data: This displays the following items:</p> <ul style="list-style-type: none"> Tool nose R: Tool radius (Nose R) R wear: Tool radius (nose R) wear amount Tool nose point P: Tool nose point (number) <p>The setting/display range of tool nose R/R wear is different depending on the combination of the settings of "#1003 iunit" and "#1041 I_inch". (Note 1) (Note2)</p> <p>Set at the radius value if parameter "#1019 dia" is "0", or at the diameter value if this parameter value is "1".</p> <p>In the case of R wear depending on the setting of parameter "#8010 ABS. MAX.", the setting/display range may be different from the above.</p> <p>An absolute setting is applied even if the tool nose point P is entered by pressing the [+ Input] menu and entering a value.</p>

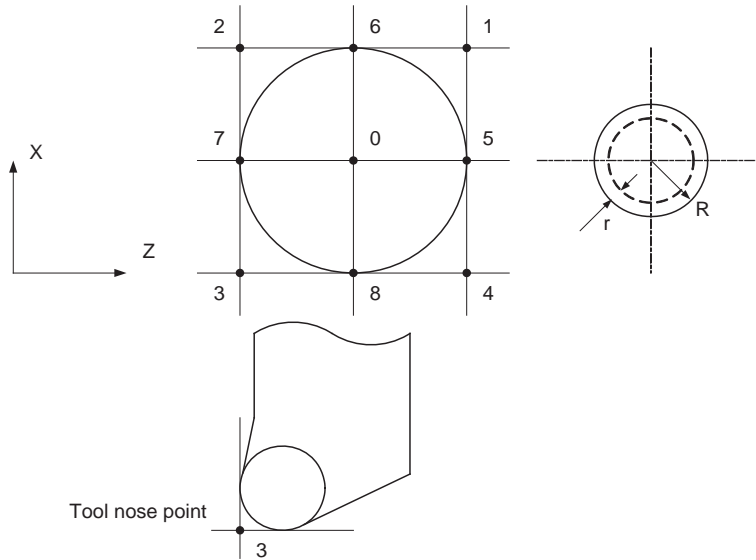

(Note 1) The setting and display ranges are as follows based on the "#1003 iunit(Input unit)" and "#1041 I_inch(Initial state (inch))" setting combination.

#1003 iunit	#1041 I_inch	Setting/display range
B	0	-9999.999 to 9999.999
	1	- 999.9999 to 999.9999
C	0	-9999.9999 to 9999.9999
	1	- 999.99999 to 999.99999

When data without the decimal point is input, a set unit can be specified by the parameter "#8119 Comp. unit switch".

(Note 2) The standard setting and display ranges are as follows.

Settings	Details	Setting/displayrange
Tool nose R	This sets the tool radius (nose R).	-9999.999 to 9999.999
R wear	This sets the tool radius (nose R) wear amount.	- 9999.999 to 9999.999
Tool nose point P	This sets the tool nose point (number).	0 to 9

The display range is when the minimum command unit is 1 μ m ("#1003 iunit"= B, "#1041 I_inch" = 0).

Menus

Same as "3.2.2.1 Wear Data".

3.2.2.4 Operation Method

(1) Setting the Tool Compensation Data

Operation method (Setting "18.000" in the X-axis tool nose wear compensation amount of compensation No. (1))

(a) Press the menu key [Offset No.]

(b) Designate the Compensation No.

1 [INPUT]

It is possible to use the [↑], [↓], [⬆] and [⬇] keys as well to move the cursor to the offset No.1.

➔ The set number appears at the top of the area, and the cursor moves.

	X	Y	Z
1	0.000	0.000	0.000
2	2.000	0.000	0.000
3	15.000	0.000	0.000
4	18.000	0.000	0.000
5	0.000	0.000	0.000
6	0.000	0.000	0.000

(c) Use the [→] key to move the cursor to the length wear position.

(d) Input the X-axis tool nose wear compensation amount.

18.000 [INPUT]

➔ The set value displays.

Settings can be made by pressing the [=INPUT] key instead of the [INPUT]key.

(Ex.) Tool compensation data [=INPUT]

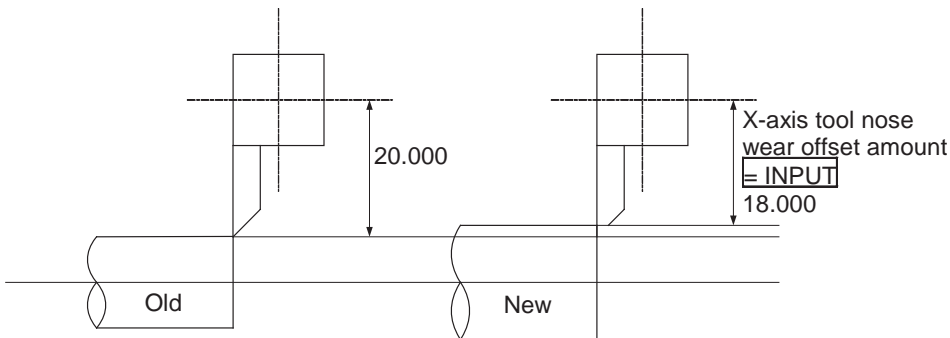

Operation method (" -2.000" is calculated and set in the X-axis tool nose wear compensation amount for compensation number (102).)

Use the same procedure as (1) above to move the cursor to the compensation No. 1 X-axis length wear position.

(b) Enter a value.
-2.000 [+INPUT]

➡ The input value is added to the original value and displays.

[Ex.] 18.000 displays if the original value is 20.000. (20.000 - 2.000 = 18.000)

(Ex.) Tool compensation data [+INPUT]

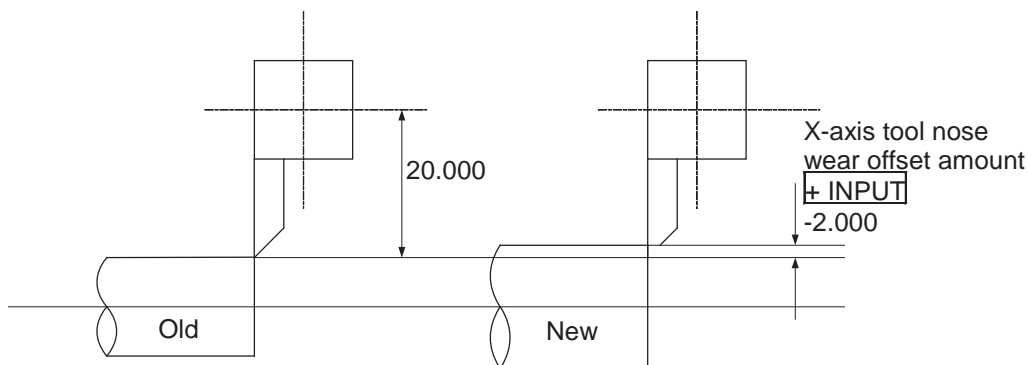

(2) Erasing the Tool Compensation Data

Operation method (Erasing one line of tool compensation data at the cursor position)

(a) Move the cursor to the line to be erased with the [↑], [↓], [▲] and [▼] keys.

➡ The cursor appears at the data item of the selected compensation No.

	X	Y	Z
1	16.000	0.000	0.000
2	2.000	0.000	0.000
3	15.000	0.000	0.000
4	13.000	0.000	0.000
5	0.000	0.000	0.000
6	0.000	0.000	0.000

(b) Press the [Line clear] and [INPUT] menu.

➡ The menu keys are highlighted and a message displays confirming whether it is okay to erase. The background color of the data to be erased displays in light blue.

(c) Press the [Y] or [INPUT] key.

➡ The selected line of data (one line amount) is cleared to zero.

The data erased to zero displays at the top of the compensation data.

	X	Y	Z
2	0.000	0.000	0.000
3	15.000	0.000	0.000
4	13.000	0.000	0.000
5	0.000	0.000	0.000
6	0.000	0.000	0.000
7	0.000	0.000	0.000

To cancel the erasing, press a key other than [Y] or [INPUT].

Operation method (Erasing the compensation data from compensation number 1 to 3.)

- (a) Press the [Line clear] menu. The menu is highlighted.
- (b) Input the compensation number of the data range to be erased. A message box displays to confirm whether it is okay to erase the data.
The background color of the data to be erased displays in light blue.
1/3 [INPUT]
- (c) Press the [Y] or [INPUT] key. The compensation data for the selected compensation number is erased, and the menu highlight returns to normal.
Press a key other than [Y] or [INPUT] in order not to erase the data. The data cleared to zero displays at the top of the compensation data.

	X	Y	Z
1	0.000	0.000	0.000
2	0.000	0.000	0.000
3	0.000	0.000	0.000
4	18.000	0.000	0.000
5	0.000	0.000	0.000
6	0.000	0.000	0.000

(Note) If the [INPUT] key is pressed without selecting an compensation number, the line where the cursor is located is erased.

(3) Copying/Pasting the Tool Compensation Data

Operation method (Copying/pasting one line of tool compensation data)

- (a) Move the cursor to the line to be copied with the [↑], [↓], and keys.
- (b) Press the [Line copy] menu. The background color of the copied data changes to light blue.
- (c) Move the cursor to the line (compensation No.: 6) where the data is to be pasted.
- (d) Press the [Line paste] menu. The copied compensation data is written in the line where the cursor is.
The background color returns to normal.
The copied compensation data is held until another line is copied.

	X	Y	Z
1	16.000	0.000	0.000
2	2.000	0.000	0.000
3	15.000	0.000	0.000
4	18.000	0.000	0.000
5	0.000	0.000	0.000
6	0.000	0.000	0.000

	X	Y	Z
1	16.000	0.000	0.000
2	2.000	0.000	0.000
3	15.000	0.000	0.000
4	18.000	0.000	0.000
5	0.000	0.000	0.000
6	15.000	0.000	0.000

(Note 1) If the compensation data for the copied line is changed after the menu [Line copy] is pressed, the data prior to the change is written when pasted.

(Note 2) It is not possible to paste the data to a different display (wear data, tool length data, tool nose data).

3.2.2.5 Disabling the Setting of Tool Compensation Amount

Depending on the setting of the parameter "#8933 Disable lngth comp"/"#8934 Disable wear comp", the setting of the shape compensation amount/wear compensation amount is disabled.

Depending on the tool compensation type, different operation will be disabled.

Tool compensation type III	"#8933 Disable lngth comp"=1	"#8934 Disable wear comp"=1
Wear	----	- Setting with the [INPUT] key is disabled. - The following menu cannot be selected. [= Input], [+ Input], [Line copy] [Line paste], [Line clear], [Undo]
Tool length	- Setting with the [INPUT] key is disabled. - The following menu cannot be selected. [= Input], [+ Input], [Line copy] [Line paste], [Line clear], [Undo]	----
Tool nose	- Setting of the tool nose R with the [= Input], [+ Input] menus, and [INPUT] key is disabled. Tool nose point P can be set. - The following menu cannot be selected. [Line copy], [Line paste], [Line clear]	- Setting of the R wear with the [= Input], [+ Input] menus, and [INPUT] key is disabled. Tool nose point P can be set. The following menu cannot be selected. [Line copy], [Line paste], [Line clear]

3.3 Tool Measurement



3.3.1 Tool Measurement (M system)

By manually moving the tool to the measurement point, the movement distance from the basic point to the measurement point is measured, and this can be set as the tool compensation amount.

Inputting an address key, such as MST, displays manual numerical value command window where manual numerical value command is executed.

There are two types of tool measurement: Tool length measurement I, Tool length measurement II

■ Tool length measurement I

When the tool is at the machine coordinate zero point, the distance from the tool tip to the measurement point (workpiece upper end) is measured, and can be set as tool compensation data.

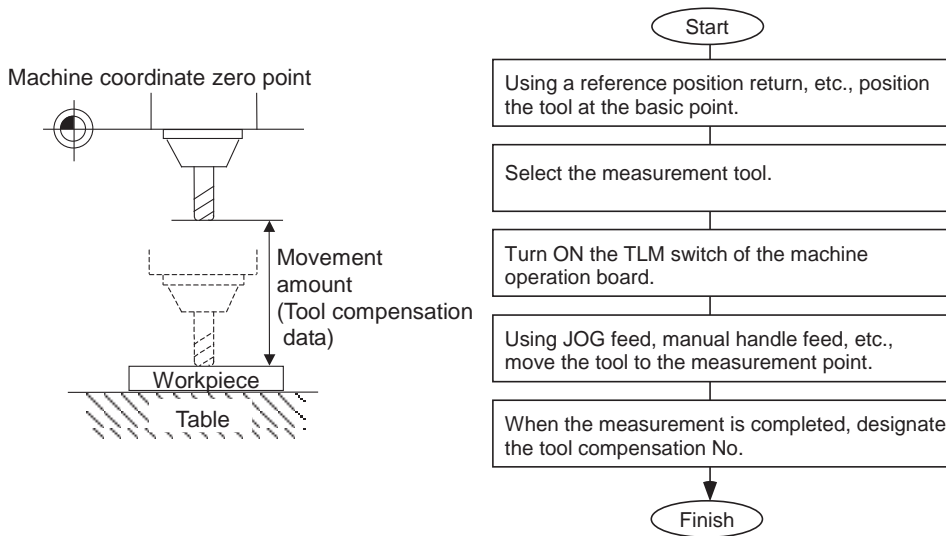

■ Tool length measurement II

When the tool is at the machine coordinate zero point, the distance from the machine coordinate zero point to the tool tip is measured, and can be set as tool compensation data.

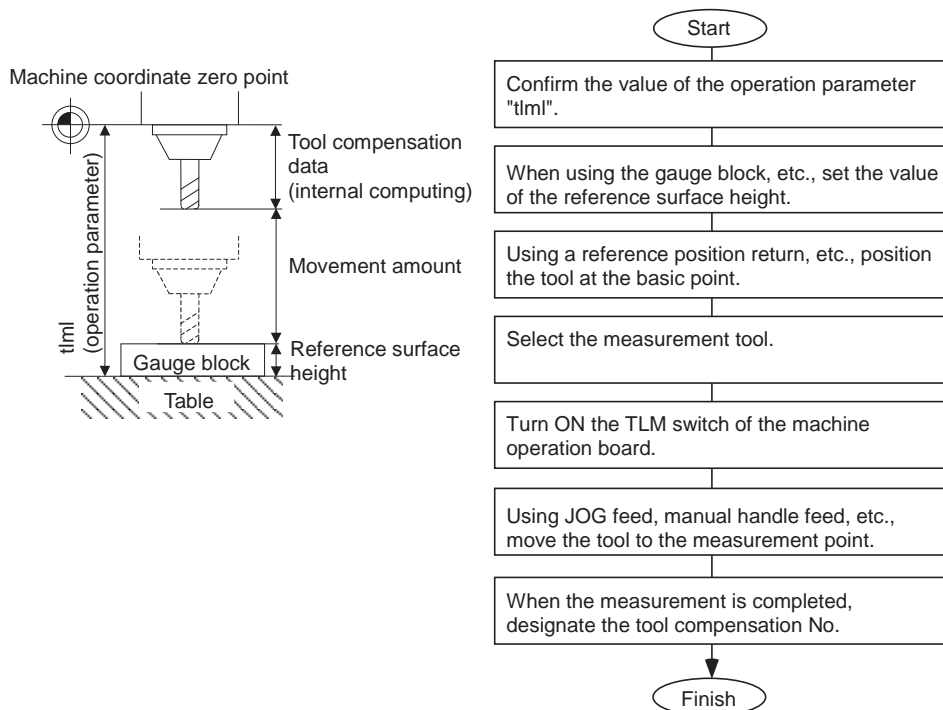

(Note) Changing of the tool measurement type is determined based on the measurement axis (tool length measurement axis, tool radius measurement axis) TLM reference length (parameter "#2016 t_lml+") at each measurement mode. When parameter "#2016 t_lml+" is "0", the tool measurement type is tool length measurement I.

■ Screen image

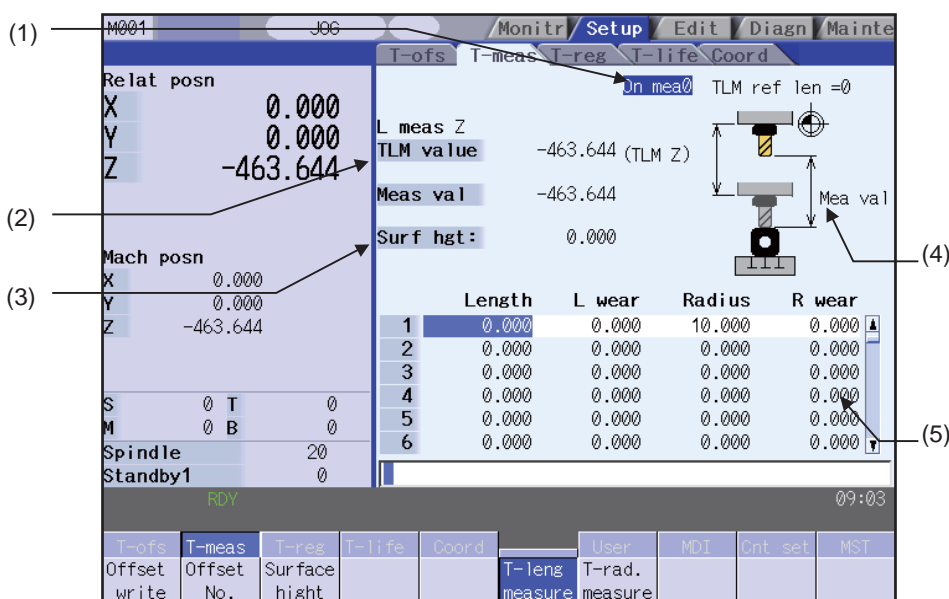

Display items

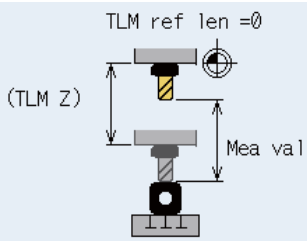
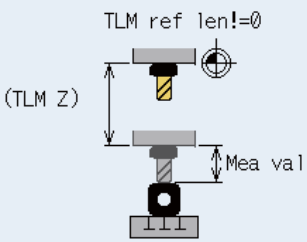
Display item		Details
(1)	Manual measurement status display	This displays the manual measurement status. Refer to the "Manual measurement status display" section for further details.
(2)	Counter display	TLM value : This displays the value during measurement. This will be the same as the machine position until the sensor is contacted. This will be the skip coordinate position after the sensor is contacted. Measurement value : For tool length measurement type I: TLM value - Reference surface height For tool length measurement type II: TLM value - Reference surface height + TLM reference length For tool radius measurement, measurement result is displayed in absolute value. (Note) The TLM value counter differs according to the parameter "#1328 TLM type" value. 0 : The position when the measurement switch was turned ON is displayed as 0. 1 : The display is based on the machine zero point.
	L meas : Z (Axis name) R meas : X (Axis name)	The axis selected in the parameters "#8711 TLM L meas axis" and "#8712 TLM D meas axis" is the target axis for the measurement.
(3)	Reference surface height	This displays a value for the reference surface height. The setting range is from -99999.999 to 99999.999(mm)
(4)	Guide drawing	This displays the measurement image. The contents of the guide drawing will differ depending on the tool measurement type. Tool length measurement I guide drawing  Tool length measurement II guide drawing 
(5)	Tool compensation data	This displays the tool compensation data. Depending on the tool compensation type (I/II), the display details of the displayed tool compensation data will differ. Cursor movement and data input operations are same as tool compensation types I and II.

Menus

Menu	Details	Type	Reference
Offset write	This writes the value displayed in "Mea value" as the tool compensation amount. The wear amount is cleared to "0" for the tool compensation type II. The tool compensation amount cannot be written in when the menu [Offset No.] or [Surface hight] is highlighted. (Note) When the parameter "#8924 MEAS. CONFIRM MSG" is "1", this menu is highlighted and the operation message "OK? (Y/N)" appears. The measurement result is written as tool compensation amount by pressing [Y] or [INPUT] key. Even if other key is pressed, the result is not written. When this menu is pressed again while displaying the message, the highlight is released and the operation message is erased.	C	
Offset No.	When the compensation No. is set and the [INPUT] key is pressed, the tool compensation data with that number at its head appears. The cursor moves to the length dimension data of the top line of that data.	A	3.2.1 Setting the Tool Compensation Data
Surface hight	This sets the reference surface height data. (The cursor moves to the reference surface height.) When the data is set in the input area and the [INPUT] key is pressed, the reference surface height is set.	A	
T-leng measure	This changes the mode to the tool length measurement mode. This mode is enabled when turning ON the power. (The cursor moves to the length dimension position for tool compensation type II. Only the length dimensions and length wear are displayed when "#11050 T-ofs digit type" is set to "1".)	B	Carrying Out Tool Length Measurement
T-rad. measure	This changes the mode to the tool radius measurement mode. (The tool measurement type is valid only for tool length measurement II.) (The cursor moves to the radius dimension position for tool compensation type II. Only the radius dimension and radius wear are displayed when "#11050 T-ofs digit type" is set to "1".)	B	Carrying Out Tool Radius Measurement

Carrying out tool length measurement

- (1) Turn ON the measurement switch.
Refer to the PLC Interface Manual for details on measurement switch signals.

➔

The message "On mea 0" appears.
- (2) Press the [T-leng measure] menu.

➔

The menu is highlighted, and the tool length measurement starts. The measurement values are displayed in "Meas value" during the measurement.
The menu [T-leng measure] is highlighted as a default after the power is turned ON.
- (3) Contact the measurement tool against the sensor, using manual feed and manual handle feed. Stop the feed when the tool contacts the sensor.

➔

When the measurement tool contacts the sensor, the skip position displayed in the measurement values counter.
- (4) The cursor moves to the compensation No. that sets the measurement results.
[Offset No.] 12 [INPUT]
The cursor display position differs depending on the measurement mode.
Tool length measurement mode:
Length dimension
Tool radius measurement mode:
Radius dimension

➔

The cursor appears.
- (5) Press the [Offset write] menu.

➔

The measurement values are written as a tool compensation amount.
The wear amount is cleared to "0" for the tool compensation type II.

(Note 1) The measurement values are not written if the cursor is in a position other than "Length" or "Radius".
 (Note 2) The axis returns and stops after contacting the sensor, but be careful not to move the axis after that. If the axis moves after contacting the sensor, the distance that was actually moved will be added to the measurement values counter, and the skip position will not be held.

- (6) Turn OFF the measurement switch to finish measuring.

➔

The message "On mea 0" disappears.

Manual measurement status display

The display will change as shown below during manual measurement.

Display	Meaning
On mea 1	This state is entered if a skip signal is input during manual measurement. The "On mea 2" state is shifted to after deceleration stop is confirmed.
On mea 2	This is the state during the first retract operation. The "On mea 3" state is shifted to after retracting the retract amount.
On mea 3	This is the state in which retract by the retract amount has completed. If the skip after deceleration stop confirmation signal is ON, the status display will remain the same. The "On mea 0" state is shifted to when this state is reset.
On mea 4	This is the state during the second measurement. If the skip signal is not input even after moving to the specified position, a warning will appear, and the status display will remain the same. The "On mea 0" state is shifted to when this state is reset
On mea 5	This state is entered when the skip signal is input during the second measurement. The "On mea 6" state is shifted to after deceleration stop is confirmed.
On mea 6	This is the state during the second return operation. The "On mea 0" state is shifted to after retracting the retract amount.
On mea 0	This state is entered when not in the "On mea 1" to "On mea 6" states.

Carrying out tool radius measurement

The operating procedure of the tool radius measurement and submenu details are the same as when measuring tool length.

(Use [T-rad. measure] instead of [T-leng measure])

Refer to "Carrying out tool length measurement" for details.

3.3.2 Tool Measurement (L system)

This is used to carry out manual tool length measurement I or II. Either one is selected depending on the setting of measurement switch and operation mode.

Inputting an address key, such as MST, displays manual numerical value command window where manual numerical value command is executed.

There are two types of key operation for Manual tool length measurement 1: normal operation mode and simple operation mode, which can be selected by the parameter "#8957 T meas (L)-Simple".

#8957	Manual tool length measurement 1 operation mode
0	Normal operation mode
1	Simple operation mode

■ Manual tool length measurement I

This is the function to calculate the tool length compensation amount automatically by moving the tool to the measurement point with manual feed. There are two types of measurement methods in manual tool length measurement I: the basic point method and the measurement value input method. The method is selected by setting parameter "#1102 tlm".

(1) Basic point method (#1102 tlm = 0)

Obtain the tool length with the tool nose placed on the measurement point.

To carry out the basic point method, a point to place the tool nose on (measurement point) is required.

Set the measurement point beforehand.

The measurement point is either the point set in the parameter "#2015 tlmI-" or the workpiece coordinate system offset (modal), which is specified by the parameter "#1282 ext18/bit2 (tool length measurement 1 measurement basic point selection)".

	#1282 ext18/bit2	Measurement point
Parameter selection method	0	The point set in the parameter "#2015 tlmI-"
Workpiece coordinate system offset selection method	1	Workpiece coordinate system offset (modal)

<Parameter selection method>

When the parameter "#1282 ext18/bit2" is "0", the measurement point will be the point offset by the amounts set in the parameter "2015 tlm1-" from the machine coordinate origin. The tool length will be automatically calculated by the method shown below.

Tool length = Machine position - Measurement basic point (#2015 tlm1-)

(Note) Always set the measurement point in radius value, regardless of the diameter/radius command.

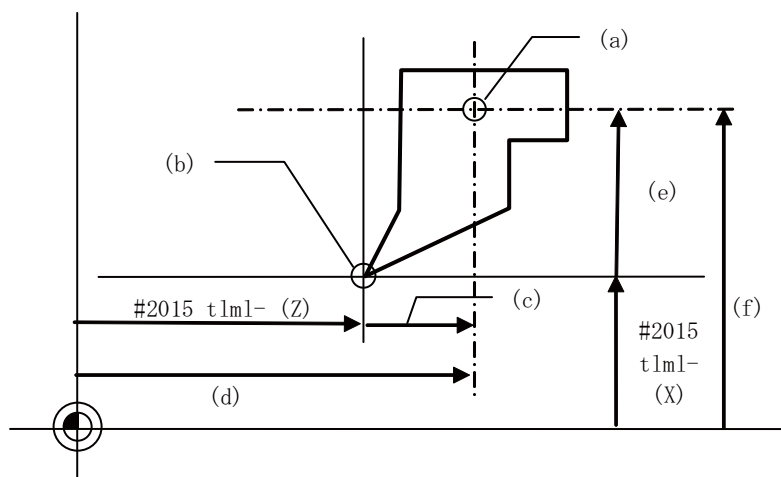

- (a) Tool length basic point
- (b) Measurement point
- (c) Z-axis tool length
- (d) Z-axis machine coordinate value
- (e) X-axis tool length
- (f) X-axis machine coordinate value

<Workpiece coordinate system offset selection method>

When the parameter "#1282 ext18/bit2" is "1", the measurement point will be the point offset by the workpiece coordinate system offsets (modal). The tool length will be the value of the workpiece coordinate position.

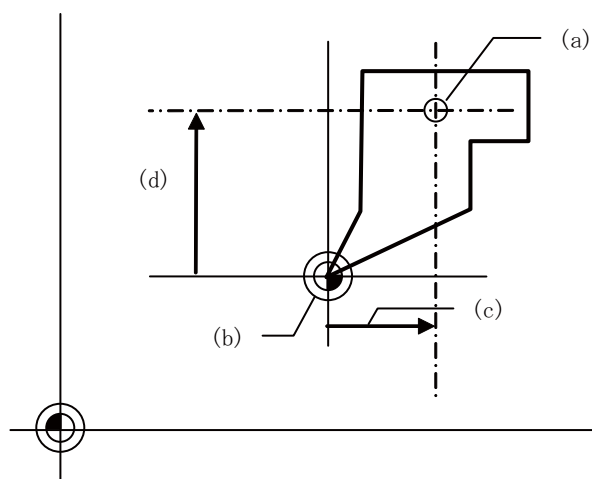

- (a) Tool length basic point
- (b) Measurement point (workpiece coordinate origin (modal))
- (c) Workpiece coordinate position = Z-axis tool length
- (d) Workpiece coordinate position = X-axis tool length

(2) Measurement value input method (#1102 tlm = 1)

Actually cut the workpiece. Measure its dimensions, and obtain the tool length from the measured values. Set the measurement basic point beforehand.

The measurement basic point is either a point specific to machines (center of chuck face, etc.) specified by the parameter "# 2015 tlm-"(the center of the chuck face, etc.) or the workpiece coordinate offset (modal), which is specified by parameter "#1282 ext18/bit2 (tool length measurement 1 measurement basic point selection)".

	#1282 ext18/bit2	Measurement point
Parameter selection method	0	The point set in the parameter "#2015 tlm-"
Workpiece coordinate system offset selection method	1	Workpiece coordinate system offset (modal)

<Parameter selection method>

When the parameter "#1282 ext18/bit2" is "0", the measurement point will be the point offset by the amounts set in "#2015 tlm1-" from the machine coordinate system origin. The tool length will be automatically calculated by the method shown below.

Tool length = Machine coordinate position - Measurement basic point (#2015 tlm1-) - Measurement value

(Note) Always set the measurement basic point in radius value, regardless of the diameter/radius command.

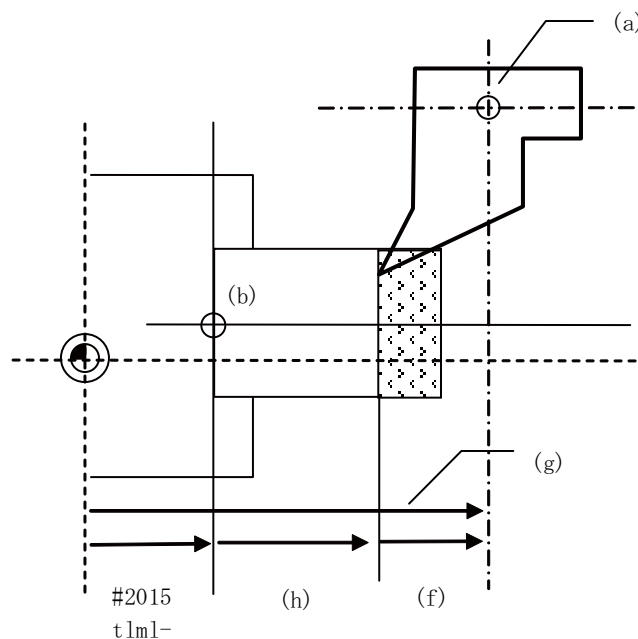
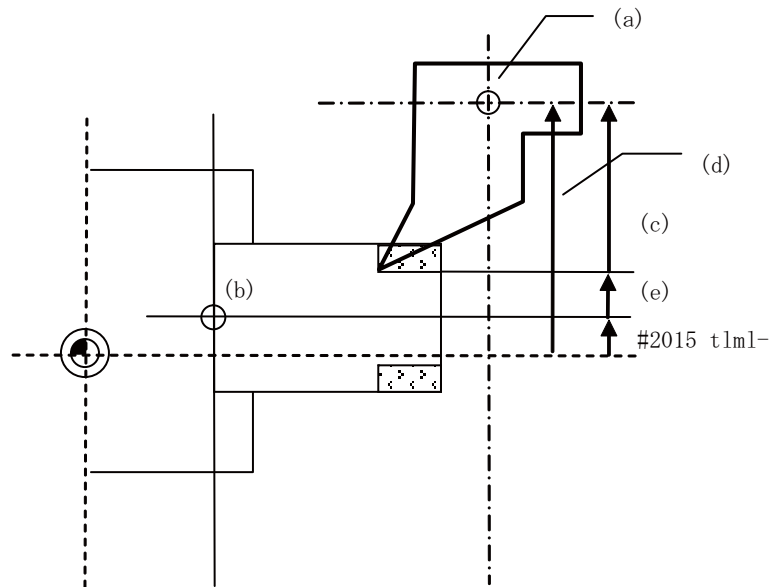

- (a) Tool length basic point
- (b) Measurement basic point
- (c) X-axis tool length
- (d) X-axis machine coordinate value
- (e) X-axis Measurement value
- (f) Z-axis tool length
- (g) Z-axis machine coordinate value
- (h) Z-axis Measurement value

<Workpiece coordinate system offset selection method>

When the parameter "#1282 ext18/bit2" is "1", the measurement point will be the point offset by the workpiece coordinate system offset (modal). The tool length will be automatically calculated by the method shown below.

$$\text{Tool length} = \text{Workpiece coordinate position} - \text{Measurement value}$$

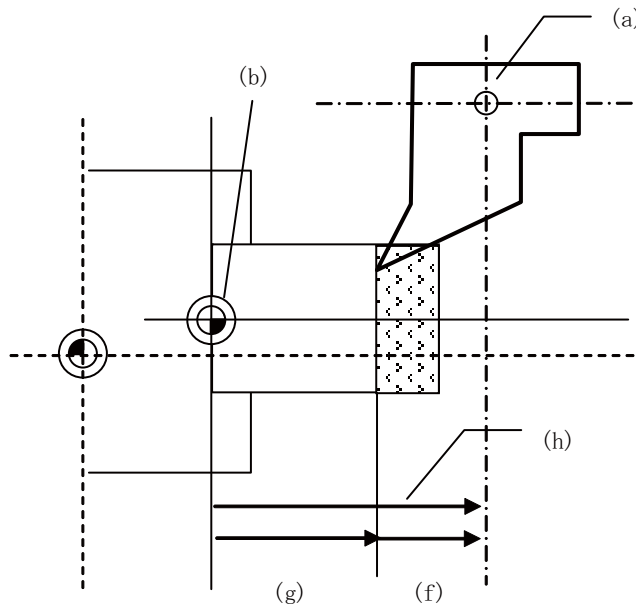
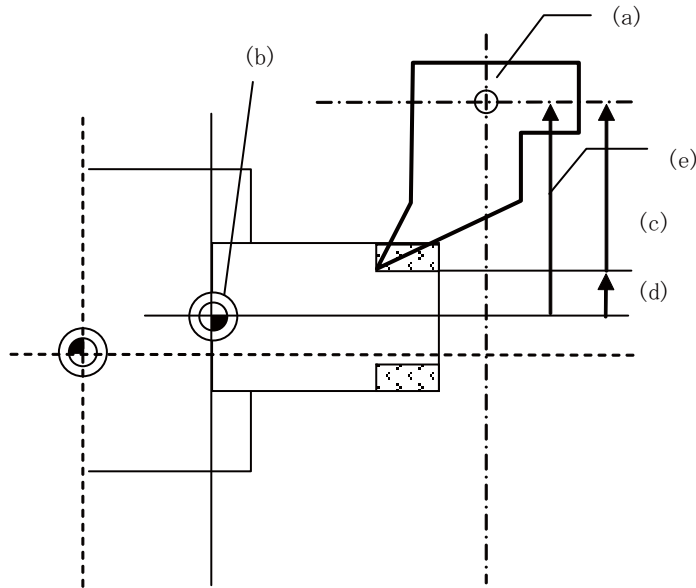

- (a) Tool length basic point
- (b) Measurement point (workpiece coordinate origin (modal))
- (c) X-axis tool length
- (d) X-axis measurement value
- (e) X-axis workpiece coordinate position
- (f) Z-axis tool length
- (g) Z-axis measurement value
- (h) Z-axis workpiece coordinate position

■ Manual tool length measurement II

By using a device having a touch sensor, the tool compensation amount can be calculated just by contacting the tool nose against the touch sensor with manual feed.

Set the measurement basic position (sensor position) with the parameter "#2015 tlm1-" and "#2016 tlm1+" when using the main spindle side, "#2097 tlm1-" and "#2098 tlm1+" when using the sub spindle side.

[Setting the measurement basic position]

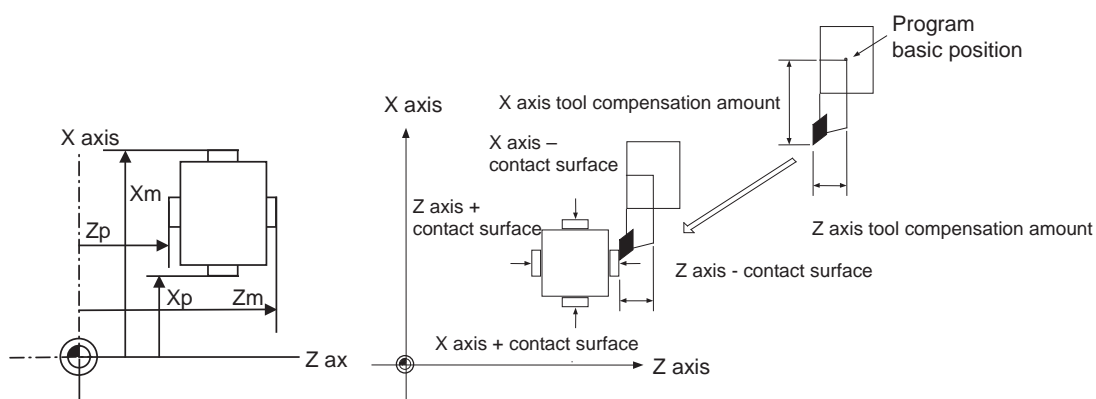

When measured at the main spindle side:

X_m : - sensor machine coordinate position X axis (position measured by moving in - direction) → #2015 tlm1- X axis

Z_m : - sensor machine coordinate position Z axis (position measured by moving in - direction) → #2015 tlm1- Z axis

X_p : + sensor machine coordinate position X axis (position measured by moving in + direction) → #2016 tlm1+ X axis

Z_p : + sensor machine coordinate position Z axis (position measured by moving in + direction) → #2016 tlm1+ Z axis

When measured at the sub spindle side:

X_m : - sensor machine coordinate position X axis (position measured by moving in - direction) → #2097 tlm12- X axis

Z_m : - sensor machine coordinate position Z axis (position measured by moving in - direction) → #2097 tlm12- Z axis

X_p : + sensor machine coordinate position X axis (position measured by moving in + direction) → #2098 tlm12+ X axis

Z_p : + sensor machine coordinate position Z axis (position measured by moving in + direction) → #2098 tlm12+ Z axis

Tool compensation amount = Machine coordinate position (machine coordinate position at the time of skip input) - Measurement basic position (sensor position)

The expression above is used for automatic calculation in Manual tool length measurement II.

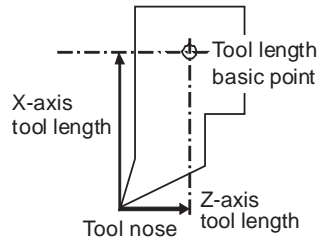

When the tool touches the touch sensor while measurement switch is ON, the calculation result is set in the tool data of the compensation No. specified with "Tool No. (Tool length measurement 2)" (PLC device), and the wear data of the compensation No. set in "Wear compensation No. (Tool presetter)" (PLC device) is cleared.

When measuring the tool length of the basic axis and inclined axis during the inclined axis control, the measurement basic position (sensor position) is set on the sensor position within the orthogonal coordinate, not the position within the machine coordinate.

(Example) When X axis is the basic axis and Y axis is the inclined axis.

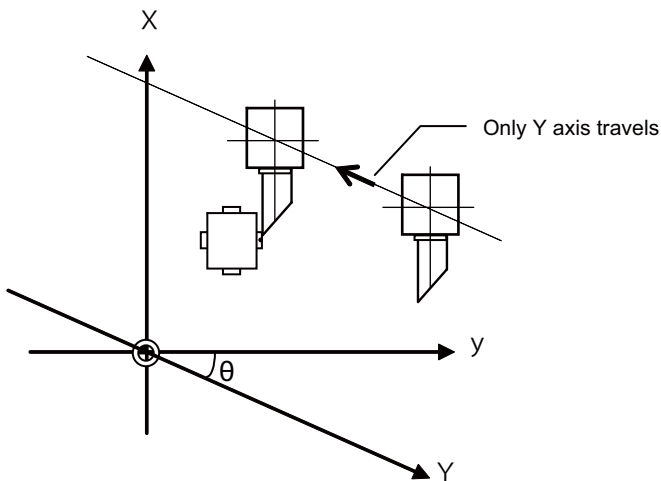

- X: Actual X axis
- Y: Actual Y axis
- y: Orthogonal coordinate
- θ : Inclined angle

■ Screen image

[Manual tool length measurement I: Basic point method]

(a) Normal operation mode

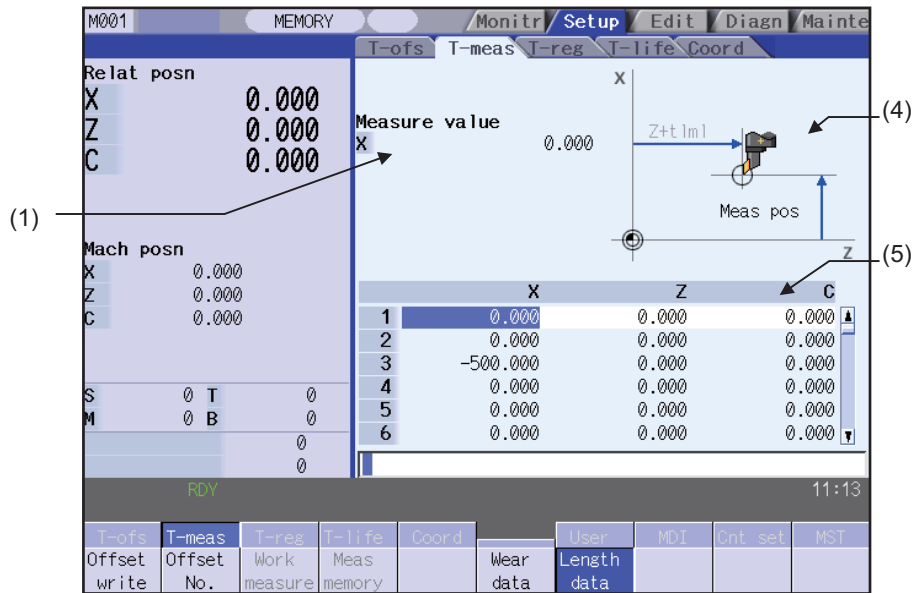

(b) Simple operation mode

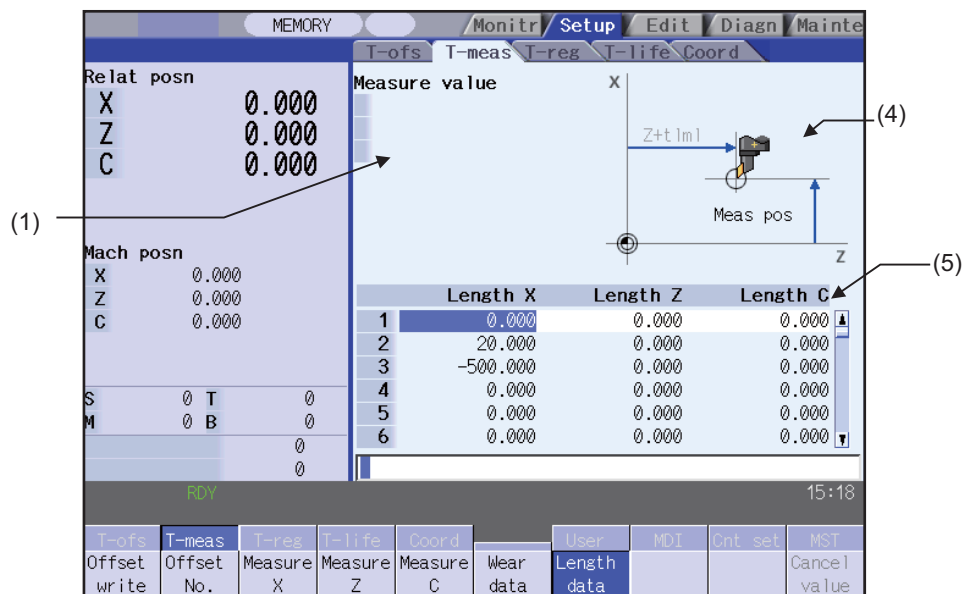

[Manual tool length measurement I: Measurement value input method]

(a) Normal operation mode

Measure value

Work meas

(1) (2) (4) (5)

	X	Z	C
1	0.000	0.000	0.000
2	0.000	0.000	0.000
3	-500.000	0.000	0.000
4	0.000	0.000	0.000
5	0.000	0.000	0.000
6	0.000	0.000	0.000

(b) Simple operation mode

Measure value

Work meas

(1) (2) (4) (5)

	Length X	Length Z	Length C
1	0.000	0.000	0.000
2	20.000	0.000	0.000
3	-500.000	0.000	0.000
4	0.000	0.000	0.000
5	0.000	0.000	0.000
6	0.000	0.000	0.000

[Manual tool length measurement II]

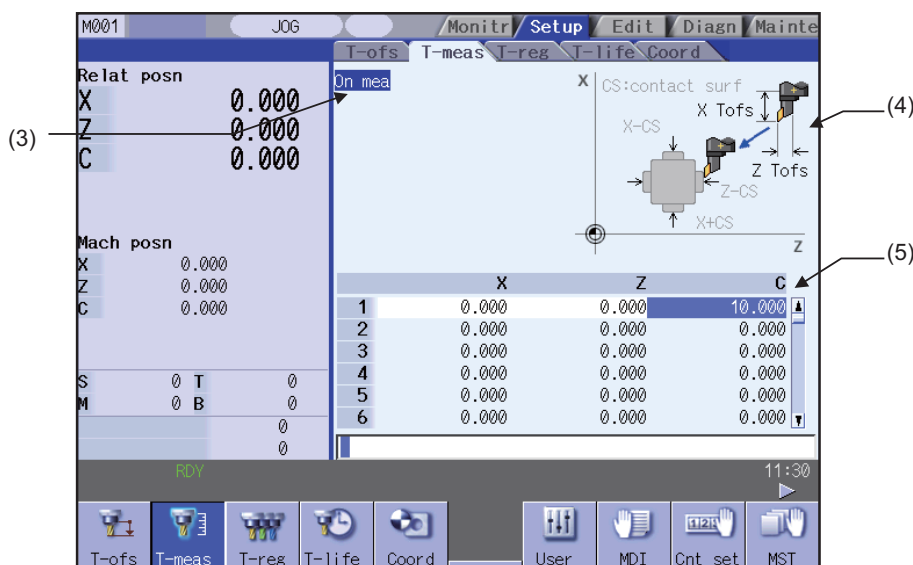

Display items

Display item	Details
(1) Measure value	<p>When "Manual tool length measurement 1", the measurement result and measurement axis are displayed. The display timing and measurement result differ, depending on whether the basic point method or measurement value input method is selected.</p> <p><Normal operation mode></p> <ul style="list-style-type: none"> - Basic point method <p>Measurement result for the axis at the cursor position is displayed at all times.</p> <p>Displayed data: Machine position - Measurement point (#2015 tml-)</p> <ul style="list-style-type: none"> - Measurement value input method <p>Measurement result is displayed when the [Meas memory] menu is pressed.</p> <p>Displayed data: Machine position - Measurement basic point (#2015 tml-)</p> <p><Simple operation mode></p> <ul style="list-style-type: none"> - Basic point method <p>Measurement result for the axis selected using either the menu [Measure X] or the axis address key.</p> <p>Displayed data: Machine position - Measurement point (#2015 tml-)</p> <ul style="list-style-type: none"> - Measurement value input method <p>Measurement result for the axis selected using either the menu [Measure X] or the axis address key.</p> <p>Displayed data: Machine position - Measurement basic point (#2015 tml-)</p> <p>(Note 1) This is displayed only in "Manual tool length measurement I".</p> <p>(Note 2) The data of maximum 3 axes displays when "Manual tool length measurement I (Simple operation mode)" is selected.</p>
(2) Work meas	<p>Workpiece measurement result is set and displayed by the measurement value input method of the manual tool length measurement I.</p> <p>Setting range: -99999.999 to 99999.999(mm)</p> <p><Normal operation mode></p> <p>Setting is possible by pressing the [Work measure] menu or touching the value area of the workpiece measurement value.</p> <p><Simple operation mode></p> <p>Select the axis to measure using either the menu [Measure X] or the axis address key. Then the cursor moves to "Work meas", where setting a measured value is enabled.</p> <p>(Note 1) This is displayed only in "Manual tool length measurement I: measurement value input method".</p> <p>(Note 2) The data of maximum 3 axes displays when "Manual tool length measurement I (Simple operation mode)" is selected.</p>
(3) On mea	<p>"On mea" is displayed when the measurement switch is ON.</p> <p>(Note) This is displayed only in "Manual tool length measurement II".</p>

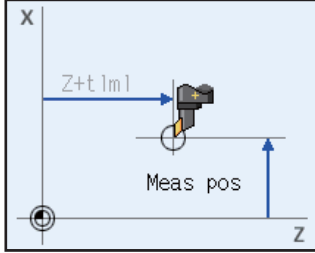
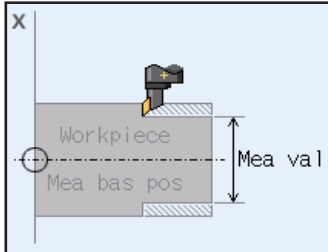
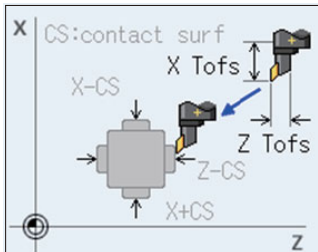
Display item	Details
<p>(4) Guide drawing</p>	<p>This displays the measurement image. The contents of the guide drawing will differ depending on the tool measurement type.</p> <p><Manual tool length measurement I: Basic point method></p>  <p><Manual tool length measurement I: Measurement value input method></p>  <p><Manual tool measurement II></p> 
<p>(5) Tool compensation data</p>	<p>This displays the tool compensation data.</p> <p>(Note 1) Cursor movement and data input operations are same as "Tool compensation type III (L system)".</p> <p>(Note 2) Automatically jumps to the compensation No. registered in "Tool No. (Tool length measurement 2)" (PLC device) during manual tool length measurement II. (Jumps even when the wear data is being displayed.) Note that the</p> <p>[↑], [↓], [▲], [▼] keys are disabled.</p>

(Note) Measurement result and workpiece measurement value will be cleared when changing of screens and measurement modes are carried out.

Menus(Manual tool length measurement 1 (normal operation mode) and Manual tool length measurement 2)

Menu	Details	Type	Reference
Offset write	<p>Depending on the mode, the following value is input as the tool compensation amount at the cursor position, and the wear amount is cleared to "0".</p> <ul style="list-style-type: none"> - Manual tool length measurement I: Basic point method "Measure value" value - Manual tool length measurement I: Measurement value input method "Measure value" value - "Work meas" value <p>In "Manual tool length measurement I: Measurement value input method", "Measure value" and "Work meas" will be cleared after compensation amount is written.</p> <p>(Note 1) Tool compensation amount cannot be written in the following cases:</p> <ul style="list-style-type: none"> - When the menu [Offset No.] and [Work measure] are highlighted - When the wear data is being displayed - When the measurement result exceeds the setting range <p>(Note 2) If "Manual tool length measurement II", this is displayed in gray and cannot be selected.</p> <p>(Note 3) When the parameter "#8924 MEAS. CONFIRM MSG" is "1", this menu is highlighted and the operation message "OK? (Y/N)" appears. The measurement result is written as tool compensation amount by pressing [Y] or [INPUT] key. Even if other key is pressed, the result is not written. When this menu is pressed again while displaying the message, the highlight is released and the operation message is erased.</p>	C	<p>Carrying out tool measurement (Manual tool length measurement I: Basic point method)</p> <p>Carrying out tool measurement (Manual tool length measurement I: Measurement value input method)</p>
Offset No.	<p>This sets the compensation No. and press the [INPUT] key. The tool compensation data is displayed, placing the No. at the top.</p> <p>(Note) If the measurement switch is turned ON, this is displayed in gray and cannot be selected.</p>	A	3.2.1 Setting the Tool Compensation Data
Work measure	<p>This sets the workpiece measurement value. If this menu is pressed, the cursor moves to the workpiece measurement value.</p> <p>Point the cursor to the axis to be set, and set the data in the data setting area. Press the [INPUT] key to set the workpiece measurement value.</p> <p>(Note) If not "Manual tool length measurement I: Measurement value input method", this is displayed in gray and cannot be selected.</p>	A	Carrying out tool measurement (Manual tool length measurement I: Measurement value input method)
Meas memory	<p>Measurement result is calculated from the current machine position and displayed.</p> <p>(Note) If not "Manual tool length measurement I: Measurement value input method", this is displayed in gray and cannot be selected.</p>	C	<p>Carrying out tool measurement (Manual tool length measurement I: Basic point method)</p> <p>Carrying out tool measurement (Manual tool length measurement I: Measurement value input method)</p>
Wear data	Wear data is displayed in tool compensation data.	B	
Length data	Tool length data is displayed in tool compensation data. This is the default mode when the power is initially turned ON.	B	

(Note) The data displayed on the tool compensation amount screen and the data displayed on "Tool compensation data" in the tool measurement screen are not linked one another. (The wear data is not necessarily displayed when the tool measurement screen has opened while the wear data is displayed on the tool compensation amount screen.)

Menus (Manual tool length measurement 1(Simple operation mode))

Menu	Details	Type	Reference
Offset write	<p>This displays the operation message "Input offset No". Input an offset No. and press the [INPUT] key. The following value is written as the tool compensation amount, and which item to write is determined by the selected mode. Then the wear amount is cleared to "0".</p> <p><Manual tool length measurement I: Basic point method> "Measure value"</p> <p><Manual tool length measurement I: Measurement value input method> "Measure value" - "Work meas"</p> <p>"Measure value" and "Work meas" will be cleared after the compensation amount is written. The cursor moves to the tool compensation data. Tool compensation amount cannot be written in the following cases. The operation message "Can't write compensation data" displays.</p> <p>(a) When the wear data is being displayed (b) When the axis to measure is not selected</p> <p>- If the measurement result exceeds the setting range, writing compensation amount fails. The operation message "Setting error" displays.</p>	A	Carrying out tool length measurement (Manual tool length measurement I: Basic point method) Carrying out tool measurement (Manual tool length measurement I: Measurement value input method)
Offset No.	<p>Set the compensation No. and press the [INPUT] key. Then the tool compensation data are listed with the Nos. placed at the top. This operation will not change the column where the cursor is placed. If this operation is carried out with the cursor placed at "Work meas", the cursor will remain displayed at "Work meas".</p>	A	Setting the Tool Compensation Data
Measure X	<p>Select the axis to measure. The menu is highlighted when it is selected. Multiple axes can be selected. To cancel, press the menu key again or press [Cancel value]. (Note 1) The axis name to be displayed follows the parameter "#1013 axname"</p>	B	Carrying out tool length measurement (Manual tool length measurement I: Basic point method) Carrying out tool measurement (Manual tool length measurement I: Measurement value input method)
Measure Z	<p>Select the axis to measure. The menu is highlighted when it is selected. Multiple axes can be selected. To cancel, press the menu key again or press [Cancel value]. (Note 1) The axis name to be displayed follows the parameter "#1013 axname".</p>	B	Carrying out tool length measurement (Manual tool length measurement I: Basic point method) Carrying out tool measurement (Manual tool length measurement I: Measurement value input method)
Measure C	<p>Select the axis to measure. The menu is highlighted when it is selected. Multiple axes can be selected. To cancel, press the menu key again or press [Cancel value]. (Note 1) The axis name to be displayed follows the parameter "#1013 axname".</p>	B	Carrying out tool length measurement (Manual tool length measurement I: Basic point method) Carrying out tool measurement (Manual tool length measurement I: Measurement value input method)
Wear data	<p>Displays wear data in the tool offset data.</p>	B	
Length data	<p>Displays length data in the tool offset data. Length data is displayed when the power is turned ON.</p>	B	

Menu	Details	Type	Reference
Cancel value	Cancels displaying the values at "Measure value" and "Work meas". The cursor moves from "Work meas" to the tool compensation data. If any mode other than "Manual tool length measurement I: Measurement value input method" is selected, this menu will be grayed out and non-selectable.	C	

(Note) The data displayed on T-ofc are not linked with the tool offset data on T-meas. (If T-meas is opened with tool wear data shown on T-ofc, the wear data will not always appear on T-meas.)

Carrying out tool length measurement (Manual tool length measurement I: Basic point method)

(a) Normal operation mode

(Example) Carrying out tool measurement for compensation No.2, Z axis

(1) Select the tool to be measured with manual numerical value command. (Refer to "3.11 Manual Numerical Value Command" for details.)



The tool to be measured is selected.

(Note) Select a tool without specifying compensation No. If compensation No. is specified, measurement result may not be obtained correctly.

(2) Manually align the tool nose with the measurement point.

(3) Point the cursor to the position (compensation No. 2, Z axis) where the measurement result are to be set.



The cursor is displayed at compensation No.2, Z axis. Calculation result of Z axis is displayed in "Measure value".

Measure value
Z 10.000

(Note) In order to measure a different axis, point the cursor to the axis to be measured and perform the following operations.

(4) Press the [Offset write] menu.



The value displayed in "Measure value" is set in compensation No.2, Z axis.

	X	Z	C
1	0.000	0.000	0.000
2	0.000	10.000	0.000
3	0.000	0.000	0.000
4	0.000	0.000	0.000
5	0.000	0.000	0.000
6	0.000	0.000	0.000

(Note 1) Compensation amount is written in diameter value for diameter command, in radius value for radius command.

(b) Simple operation mode

(Example) Carrying out tool measurement for compensation No.4, X axis and Z axis

(1) Select the tool to be measured with a manual numerical value command. (Refer to "3.11 Manual Numerical Value Command" for details.) ➡ The tool to be measured is selected.

(2) Manually align the tool nose with the measurement point.

(3) Press the address key of the axis to measure (X axis) or the [Measure X] menu. ➡ Calculation result of X axis is displayed in "Measure value". The [Measure X] menu is highlighted.

Measure value	
X	30.000

(4) To measure another axis continuously, press the address key of the axis to measure (Z axis) or the [Measure Z] menu. ➡ Calculation result of Z axis is displayed in "Measure value" by maintaining the X axis "Measure value". The [Measure Z] menu is highlighted.

Measure value	
X	30.000
Z	10.000

(5) Press the [Offset write] menu. ➡ The operation message "Input offset No." displays.

(6) Input an offset No. (Example) 4 [INPUT] ➡ The measurement result will be set in the specified offset No. (X and Z axes). The specified offset No. will display at the top and the cursor will move to the same line.

	X	Z	C
4	30.000	10.000	0.000
5	0.000	0.000	0.000
6	0.000	0.000	0.000
7	0.000	0.000	0.000
8	0.000	0.000	0.000
9	0.000	0.000	0.000

(Note) The measurement value is cleared and the highlight of the menus ([Measure X] to [Measure C]) is canceled.

- (Note 1) Compensation amount is written in diameter value for diameter command, or in radius value for radius command.
- (Note 2) When offset write is executed for an axis that has not completed zero point return, the operation message "TLM axis not returned to ref. position" will appear.
- (Note 3) When the base common parameter "#1124 ofsfix" is "0", the cursor moves to the next offset No. However, when "#1124 ofsfix" is "1", the cursor does not move to the next offset No.
- (Note 4) When the parameter "#11017(T-ofs set at run" is "1)", the tool compensation amount data can be set even during automatic operation or operation pause.

Carrying out tool measurement (Manual tool length measurement I: Measurement value input method)

(a) Normal operation mode

(Example) Carrying out tool measurement for compensation No.3, X axis

- (1) Select the tool to be measured with manual numerical value command. (Refer to "3.11 Manual Numerical Value Command" for details.) → The tool to be measured is selected.
(Note) Select a tool without specifying compensation No. If compensation No. is specified, measurement result may not be obtained correctly

- (2) Point the cursor to the position (compensation No. 3, X axis) where the measurement result are to be set. → The cursor is displayed at compensation No.3, X axis.
(Note) In order to measure a different axis, point the cursor to the axis to be measured and perform the following operations.

- (3) Cutting is executed in the longitudinal direction. (For the Z axis, face turning is executed.)

- (4) The [Meas memory] menu is pressed without retracting the tool at the end of cutting operation. → Measurement result is displayed.

Measure value
X 20.000

- (5) Retract the tool and measure the workpiece. And then press the [Work measure] menu. → The [Work measure] menu is highlighted and the cursor moves to the workpiece measurement value.

Work meas	0.000
-----------	-------

- (6) Set the workpiece measurement result. → 10 is set for the workpiece measurement value.

10 [INPUT]

Highlight of the [Work measure] menu is canceled and the cursor moves to the tool compensation data.

Work meas	10.000
-----------	--------

(Note) Set a diameter value for diameter command and a radius value for radius command.

"Measurement result - workpiece measurement value" is set to compensation No.3, X axis.

- (7) Press the [Offset write] menu. →

	X	Y	Z
1	0.000	0.000	0.000
2	0.000	10.000	0.000
3	10.000	0.000	0.000
4	0.000	0.000	0.000
5	0.000	0.000	0.000
6	0.000	0.000	0.000

(Note 1) Compensation amount is written in diameter value for diameter command, in radius value for radius command.

(b) Simple operation mode

(Example) Carrying out tool measurement for compensation No.3, X axis and Z axis

- (1) Select the tool to be measured with a manual numerical value command. (Refer to "3.11 Manual Numerical Value Command" for details.)



The tool to be measured is selected.

- (2) Execute cutting in the longitudinal direction.(For Z axis, execute end-face cutting.)

- (3) Press the address key of the axis to measure or the [Measure X] menu, without retracting the tool from the cutting end point.



The measure value is memorized. The memorized value is displayed at "Measure value", and the cursor moves to "Work meas".
The operation message "Input workpiece measurement value" displays.

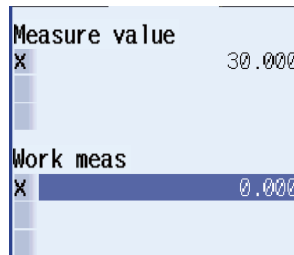

- (4) To measure the other axes at the same time, repeat (2) to (3).



The measurement values of the selected axes are recorded and displayed at "Measure value". The cursor will not move from the top line.

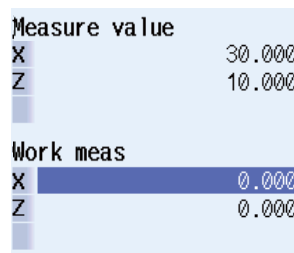

- (5) Retract the tool and measure the workpiece.

- (6) Set the workpiece measurement result in "Work meas".
Example) 10 [INPUT]



The value 10 is set in the top line of "Work meas".
If there are two or more axes to measure, the cursor moves down to the next line.

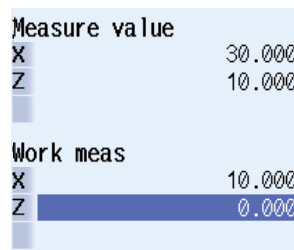

(Note) Compensation amount is written in diameter value for diameter command, or in radius value for radius command.

- (7) To set the measurement results of the other axes, repeat (6).
Example) 5 [INPUT]



The value "5" is set to the 2nd line of "Work meas".

Measure value	
X	30.000
Z	10.000
Work meas	
X	10.000
Z	5.000

(Note 1) Compensation amount is written in diameter value for diameter command, or in radius value for radius command.

- (8) Press the [Offset write] menu.



The operation message "Input offset No." displays.

- (9) Input an offset No.
(Example) 3 [INPUT]



The result of "Measure value - Work meas" will be set in the specified offset No. (X and Z axes). Specified offset No will display at the top and the cursor will move to the same line.

	X	Z	C
3	20.000	5.000	0.000
4	0.000	0.000	0.000
5	0.000	0.000	0.000
6	0.000	0.000	0.000
7	0.000	0.000	0.000
8	0.000	0.000	0.000

(Note) The measurement value is cleared and the highlight of the menus ([Measure X] to [Measure C]) is canceled.

- (Note 1) Compensation amount is written in diameter value for diameter command, or in radius value for radius command.
- (Note 2) When offset write is executed for an axis that has not completed zero point return, the operation message "TLM axis not returned to ref. position" will appear.
- (Note 3) When the base common parameter "#1124 ofsfix" is "0", the cursor moves to the next offset No. However, when "#1124 ofsfix" is "1", the cursor does not move to the next offset No.
- (Note 4) When the parameter "#11017(T-ofs set at run" is "1)", the tool compensation amount data can be set even during automatic operation or operation pause.

Carrying out tool measurement (Manual tool length measurement II)

- (1) Select the tool to be measured with manual numerical value command. (Refer to "3.11 Manual Numerical Value Command" for details.) ➔ The tool to be measured is selected.
- (2) Set the compensation No. of the compensation data to be set in "Tool No. (Tool length measurement 2)" (PLC device). ➔ The compensation No. of the compensation data to be set is selected.
- (3) Set the compensation No. of the wear data to be cleared in "wear compensation No. (tool presetter)" (PLC device). ➔ The compensation No. of the wear data to be cleared is selected.
- (4) Turn the measurement switch ON. ➔ "On meas" is displayed. Guide drawing for manual tool length measurement II is displayed. Tool compensation data is displayed, placing the compensation No. set in "Tool No. (Tool length measurement 2)" (PLC device) at the top.

	X	Y	Z
4	0.000	0.000	0.000
5	0.000	0.000	0.000
6	0.000	0.000	0.000

(Note) The row at the cursor position will not be changed.

- (5) Move the additional axis in the minus direction by manual feed and have the tool nose contact with the touch sensor. ➔ Measurement value is set for the additional axis of the compensation No. set in "Tool No. (Tool length measurement2)" (PLC device)

	X	Y	Z
4	0.000	0.000	10.000
5	0.000	0.000	0.000
6	0.000	0.000	0.000

- (6) Turn the measurement switch OFF. ➔ "On meas" disappears.

(Note 1) When entering the sensor area, the axis can be moved only in one direction selected from +X, -X, +Z, -Z, (+Y, -Y). If two axes are moved simultaneously, measurement will not be carried out. At this time, "TLM axis is illegal" is displayed and the axis movement stops.

(Note 2) If the tool nose is contacting the sensor, the axis can be moved only in the direction moving away from the sensor. Whether or not the tool nose is detached from the sensor can be judged by the following conditions.

- The sensor signal has been turned OFF for 500ms or more.
- The tool nose is moved 100 μ m or more after the sensor signal has turned OFF.

The above conditions are set with parameter "#1227 aux1 1/bit2".

3.4 Tool Registration



A tool No. is assigned to each tool to make the tools installed on the machine recognizable to the NC. The tool No. is registered corresponding to the magazine pot and spindle where that tool is installed, and the standby location. When the tool No. and magazine pot are changed by a tool selection command or tool replacement command, the new tool No. is displayed

When not making an arbitrary setting for the number of registered tools, there are maximum 3 magazines, and up to 120 tools can be registered for each magazines. When making an arbitrary setting, there are a maximum of 5 magazines, and up to 360 tools can be registered for all magazines.

This function differs depending on the specifications of the machine tool builder. Refer to the instruction manual issued by the machine tool builder for details.

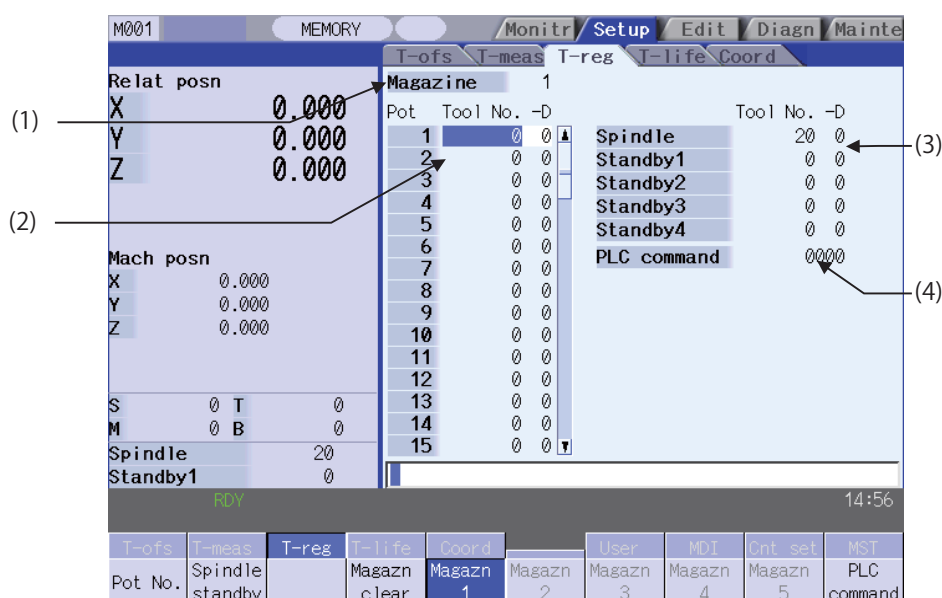

Inputting an address key, such as MST, displays manual numerical value command window where manual numerical value command is executed.

Display items

Display item	Details
(1) Magazine	This displays the currently selected magazine No.
(2) Tool No.-D	A maximum of 8 digits of data can be input for a tool No. (Refer to the instruction manual issued by the machine tool builder for D functions and purposes.) When the "Tool No." column is blank, confirm the tool first, since the tool could not be mounted, or the tool could not match the spindle. Setting "0" erases the registered tool.
(3) Spindle/Wait (used by PLC program)	This displays the magazine 1 spindle or standby tool No. (The name of this area differs depending on the output from the PLC program.) (Note) Displayed contents depend on the ATC parameter setting.
(4) PLC command	This command is used to input data and perform sequence processing using the PLC program.

Menus

Menu	Details	Type	Reference
Pot No.	Set the magazine pot number and press the [INPUT] key to position that pot number at the top and display the tool number. The cursor moves to the tool number for that pot number.	A	3.4.1 Registering a Tool in the Magazine Pot
Spindle standby	This sets or erases the tool No. of spindle and standby tools. The cursor will move to the top tool No. of the spindle and standby tools and the setting mode will be entered.	A	3.4.3 Setting/Erasing the Tool No. of Spindle/Standby Tools
Magazn clear	This erases all the currently selected magazine tool data (tool number and D). (Note 1) Unselected magazine tool data is not erased. (Note 2) The spindle and standby data cannot be erased.	A	3.4.3 Setting/Erasing the Tool No. of Spindle/Standby Tools
Magazn 1 : : : Magazn 5	This designates the magazine No. to be displayed on the screen. The displayed menu differs according to the machine specifications. [Ex.] When there are two magazines, only the menu [Magazine 1] and [Magazine 2] keys display.	B	3.4.1 Registering a Tool in the Magazine Pot
PLC command	The cursor moves to the PLC command setting area and the mode changes to the setting mode.	B	3.4.2 Setting the PLC Command

Tool registration duplication check

When the tool No. is set to the magazine pot and the spindle/standby, tool registration duplication can be checked. Either of "Executing the duplication check for all valid magazines", "The duplication check invalid" or "Executing the duplication check only in the selected magazine" can be selected by the parameter "#8922 T-reg-no dup check".

<Priority of duplication check>

Operation	Setting of the operation parameter "T-reg-no dup check"		
	0:Executing the duplication check for all valid magazines	1:The duplication check invalid	2:Executing the duplication check only in the selected magazine
Register tool to magazine pot (Refer to 3.4.1 Registering a Tool in the Magazine Pot)	1. Magazine n (n =1,2···) 2. Spindle/standby	The duplication check is not executed.	1. Selected magazine 2. Spindle/standby
Set tool No. to spindle/standby (Refer to 3.4.3 Setting/Erasing the Tool No. of Spindle/Standby Tools)	1. Spindle/standby 2. Magazine n (n =1,2···)	The duplication check is not executed.	1. Spindle/standby 2. Selected magazine

3.4.1 Registering a Tool in the Magazine Pot

Operation method (Selecting a magazine No.)

- (1) Press the menu [Magazn 2].



The tool data of the set magazine No. appears.

Pot	Tool No.	-D
1	12345678	32
2	2	0
3	3	0

(Note) The No. of magazines differs according to the machine specification.

Operation method (Registering the tool in the magazine pot)

- (1) Designate the pot No.

[Pot No.] 21 [INPUT]



The tool data appears with the designated pot No. at the head. The cursor moves to the tool No. setting column.

Pot	Tool No.	-D
21	5678	2
22	2	0
23	3	0

- (2) Input the tool number.

50 [INPUT]



The input tool number displays and the cursor moves to the next tool number.

Pot	Tool No.	-D
21	50	2
22	2	0
23	3	0

When the [INPUT] key is pressed without setting a value, the tool number does not change and the cursor moves to the "tool number" for the next pot number.

When the duplication check is valid, the operation message "Exists in magazine 1. Set? (Y/N)" or "Exists in spindle/standby. Set? (Y/N)", etc. appears if the input tool No. already exists in valid magazine, spindle/standby.

(Note 1) To set "D", use the  key to move the cursor.

Refer to the manual issued by the machine tool builder for details on the "D" functions and purposes.

(Note 2) The duplication check is executed for only the tool No. The check does not depend on the setting of "D".

(Note 3) If parameter "#8922 T-reg-no dup check" is set to "1", the operation message will not appear even when the tool No. duplicates.

3.4.2 Setting the PLC Command

Operation method (Setting the PLC command)

- (1) Set the value after the [PLC command] menu.
[PLC command] 12 [INPUT] → The set value displays in the PLC command setting field, and the PLC command setting mode is enabled.
The function of the command depends on the machine tool builder's specifications.

PLC command 0012

(Note) Select the [PLC Command] menu again before pressing the [INPUT] key, then the menu highlight returns to normal, and the PLC command setting mode becomes disable.

- (2) Press the menu [PLC command] , or the [Left Arrow] key → The PLC command setting mode is released, and the menu highlight returns to normal.

3.4.3 Setting/Erasing the Tool No. of Spindle/Standby Tools

Operation method (Setting the tool No. of spindle/standby tools)

- (1) Press the [Spindle standby] menu. → The cursor appears at the top tool No. of spindle/standby.
In addition, the first "D" column is highlighted.
- (2) Move the cursor to the data to be set using the [↑], [↓] keys.
- (3) Input a new tool No.
50 [INPUT] (Note1) → The tool No. changes. The cursor moves to the next tool No.
- (4) Press the [Spindle standby] menu again or [Left Arrow] key → The spindle/standby setting mode is cancelled.
to quit the spindle/standby setting mode.

(Note 1) When the [Spindle standby] menu again or [Left Arrow] key is pressed before pressing the [INPUT] key, the spindle/standby setting mode will be cancelled and the set data will be ignored.

(Note 2) Move the cursor with [Right Arrow] key to set the "D" data.

Operation method (Erasing the tool No. of spindle/standby tools)

- (1) Press the [Spindle standby] menu. → The cursor appears at the top tool No. of spindle/standby.
In addition, the first "D" column is highlighted.
- (2) Move the cursor to the tool No. to be erased and input "0".
0 [INPUT] → The tool No. of spindle/standby changes to "0".

(Note 1) Move the cursor with [Right Arrow] key and set "0" to erase the "D" data as the same manner as the tool No.

3.4.4 Erasing the Tool Registration Data

Operation method (Selecting a magazine number and erasing the tool registration data.)

- | | | |
|------------------------------------|---|--|
| (1) Press the menu [Magazn 2]. | ➔ | The tool registration data of the selected magazine No. appears. |
| (2) Press the menu [Magazn clear]. | ➔ | A message displays confirming whether it is okay to erase. |
| (3) Press the [Y] or [INPUT] key. | ➔ | All selected magazine tool data (tool number and D) is erased.
Spindle/standby tool data is not erased. |

3.5 Tool Life Management



The life management data of the tool usage conditions, etc., is set and displayed.

The tool life management specifications differ between the M and L system. There are three tool life management methods with the setting of "#1096 T_Ltyp" for M system, and two for L system.

Inputting an address key, such as MST, displays manual numerical value command window where manual numerical value command is executed.

<M system>

■ Tool life management I

The usage time or No. of uses of the tool commanded in the program is incremented, and the usage state of that tool is monitored.

■ Tool life management II

This method is the same as tool life management I, but with a spare tool selection function added.

A spare tool is selected from the group of tool commands commanded in the program. Tool compensation (tool length compensation and tool radius compensation) is carried out for the selected tool.

The tool life management related parameters (basic common parameters) include the following.

#	Item	Setting	Details
1103	T_Life T-life manage valid	0	This ignores the tool life management data.
		1	This controls the tool life management.
1104	T_Com2 Tool com 2 (When tool life management is valid.)	0	This treats the program tool command as a group No. Search for the group No. that matches with the tool No. in the tool registration data, and select the spare tool from there.
		1	This treats the program tool command as a tool No.
1105	T_sel2 Tool com 2 (When tool life management is valid.)	0	This selects the tool from the tools in use in the same group, following the registration No. order. If there are no "Tools in use", the tools are selected in order of "Tools not in use", "Normal life tools" and "Abnormal tools", following the registration No. order.
		1	This selects the tool with the maximum remaining life from the tools in use and not in use in the same group. When several tools have the same remaining life, the tools are selected in order of registration No. If there are no "Tools in use" or "Tools not in use", the tools are selected in order of "Tools not in use", "Normal life tools" and "Abnormal tools", following the registration No. order.

■ Tool life management III

It is not managed by the group number.

The usage time, the No. of uses or the wear amount of the tool which is designated by the program is accumulated, and the tool usage state is monitored.

<L system>

■ Tool life management I --- Tool life data display

The tool usage time and usage count indicated in the program is accumulated, and the usage status for that tool is monitored.

Tool life management can be performed for a maximum of 80 tools (tool Nos. 1 to 80).

(a) Time based control

The cutting time (G01, G02, G33 etc.) after performing the tool selection command (T) is calculated in the tool usage time corresponding to the designated tool.

A warning is issued if the usage time at the time the tool selection command is performed reaches the life time.

(b) Usage count based control

The tool usage count corresponding to the designated tool No. increases each time the tool selection command (T) is performed.

A warning is issued if the usage count at the time the tool selection command is performed exceeds the life time.

■ Tool life management II --- Tool life data display / registration group list display

The life (usage time, usage count) of each tool is controlled, and if the life is reached, the same spare tools are selected and used one by one from the group to which that tool belongs.

- Group count : Multi-part system spec. : max. 80 groups

- No. of tools in group: Max. 16

The tool life management related parameters (basic shared parameters) are shown below.

#	Name	Setting	Details
1096	T_Ltyp	1, 3	Tool life management I
	Tool life management type	2	Tool life management II
1103	T_Life	0	The tool life management is not performed.
	Enable tool life management	1	The tool life management is performed.
1107	TlIfsc		Set the no. of groups displayed at the tool life management II (L series) screen.
	(For L system only)	0	Displayed no. of groups: 1, Max. No. of registered tools: 16
	Tool life management	1	Displayed no. of groups: 2, Max. No. of registered tools: 8
	Display screen division	2	Displayed no. of groups: 4, Max. No of registered tools: 4

The tool life management screen is made up of the group list display screen and the life management data screen.

(There is no group list display screen in L system tool life management 1. Only the life management data screen exists.)

Refer to the following sections for details of the display contents, menus, and an explanation of the operations for each screen.

"3.5.1 Displaying the Group List"

"3.5.2 Displaying the Life Management Data in Group Units (M system)"

"3.5.3 Displaying the Life Management Data (L system: Tool life management I)"

"3.5.4 Displaying the Tool Life Management Data in Group Units (L system: Tool life management II)"

3.5.1 Displaying the Group List (M system: Tool life management I, II / L system: Tool life management II)

Tool life management data groups can be registered and erased.

<M system>

When changing from a group unit display to the group list display, the cursor displays at the group No. at the group unit display.

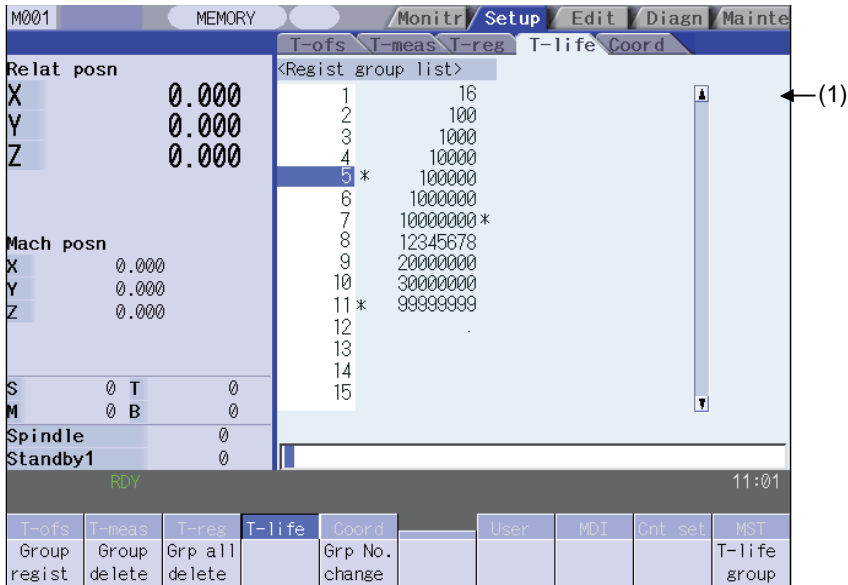

Display items (M system)

Display item	Details
(1) Regist group list	<p>The group Nos. registered as the tool life management data are listed in ascending order. Group Nos. can be set from 1 to 99999999, and maximum 1000 groups (Note) can be set.</p> <p>Maximum 60 groups can be displayed at a time. Use the / keys to change the display if the No. of registered groups exceeds 60.</p> <p>An asterisk will be added to the No. of the group in which all tools have reached their lives. (Note 1) The maximum number of the registered groups is 200.</p> <p>(Note 2) In tool life management II, when all the tools' statuses (ST) of the target group become 2 to 4, "*" will be displayed.</p>

<L system>

The tool life management data currently being used and the group list are displayed.

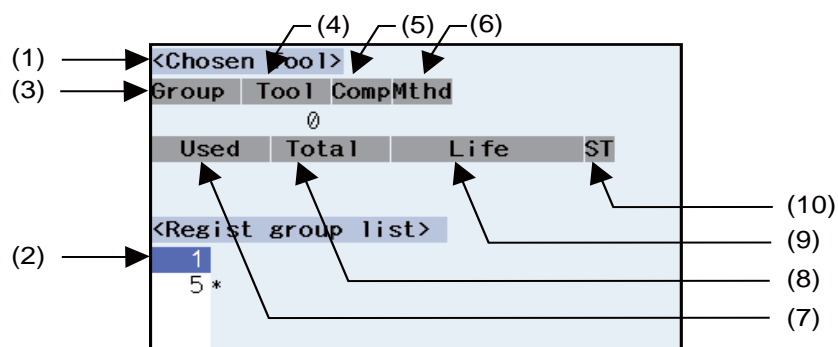

Display items (L system)

Display item	Details
(1) Chosen Tool	The life management information of the tool currently being used appears here.
(2) Register group list	The group Nos. registered as the tool life management data are displayed in a list. Group Nos. can be set from 1 to 9999, and maximum 80 groups can be set. An asterisk will be added to the No. of the group in which all tools have reached their lives.

[CHOSEN TOOL]

Display item	Details	Display range
(3) Group	Displays the life management group No. currently being used.	1 to 9999
(4) Tool No.	Displays the tool No. currently being used.	1 to 999999
(5) Comp No.	Displays the compensation No. currently being used.	1 to 80
(6) Mthd	Displays whether the group currently being used is controlled by the usage time or usage count.	0: Time 1: Count
(7) Used	Displays the usage data for the tool currently being used.	Usage time: 0 to 99999999 (s)
		Usage count: 0 to 999999 (set)
(8) Total	Displays the total usage data for the tool currently being used. In the case of tools using multiple compensation Nos., the total usage data for all compensation Nos. displays. In the case of only one compensation No., the same value as "Used" displays.	Usage time: 0 to 99999999 (s)
		Usage count: 0 to 999999 (set)
(9) Life	Displays the life value for the tool currently being used.	Usage time: 0 to 99999999 (s)
		Usage count: 0 to 999999 (set)
(10) ST	Displays the status of the tool currently being used.	0: Unused tool
		1: Used tool
		2: Normal life tool 3: Skipped tool

Menus (M system/L system)

Menu	Details	Type	Reference
Group regist	Creates a new group and adds the group No. to the list.	A	"Registering a group"
Group delete	This erases all of the tool life management data included in the designated group No. If the group No. is not designated, the tool life management data for the group No. indicated by the cursor will be erased.	A	"Erasing a group"
Grp all delete	This erases all groups and their tool life management data registered.	A	"Erasing all groups"
Grp No. change	Changes the group No.. Specify a new group No. and press the [INPUT] key to change the group No. and then change the contents of the list. An error occurs if an existing group No. is specified.	A	"Changes the group No."
T-life group	The tool life data for the group No. indicated by the cursor will be displayed. This changes to the mode enabling tool life management data to be set and displayed with group unit Nos.	C	"Changing to the group unit display"

Operation method (Registering a group) (M system/L system)

- (1) Press the menu [Group regist].
- (2) Designate the group No. to be registered.  The life management data for the selected group No. displays empty.
25 [INPUT]
The group No., method, and life value is set at the L system.
(Example) 25/1/3000 [INPUT]



- (Note 1) An error occurs if the group No. duplicates a pre-existing group No.
 (Note 2) The group is not registered if the following operations are performed after newly registering a group No..
 - The application is exited without registering even 1 item of tool life data.
 - The screen is changed to that of other than the group unit display.

Operation method (Erasing a group) (M system/L system)

- (1) Press the menu [Group delete].
- (2) Designate the group to be erased.  The selected group No. is erased.
72 [INPUT]

If nothing is input in the input area, the group at the cursor location is erased.





Operation method (Erasing all groups) (M system/L system)

- (1) Press the menu [Grp all delete].  The confirmation message appears.
- (2) Press the [Y] or [INPUT] key.  All the registered groups and their tool life management data is erased.

(Note 1) If no group has been registered, the operation message "Can't delete all groups" will appears.



Operation method (Changing the group No.) (M system/L system)

(Ex.) Changing the group No. from 5 to 20

- (1) Use the [↑], [↓],  and  keys to move the cursor to group No. 5.
- (2) Press the menu [Group change] key.  The menu is highlighted.
- (3) Set the new group No..  The group No. changes to "20".
20 [INPUT]

Operation method (Changing to the group unit display) (M system/L system)

(Ex.) Displaying the group No. 5 tool life data.

- (1) Use the [↑], [↓],  and  keys to move the cursor to group No. 5.
- (2) Press the menu [T-life group] or [INPUT] keys.  The screen changes to the group unit display and the group No. "5" tool life management data displays.

<M system>



Group No.		5			
#	Tool No.	ST	Mthd	L compen	R compen
1	301	00	000	0	0
2	302	00	000	0	0
3	303	00	000	0	0
4	304	00	000	0	0
5	305	00	000	0	0

<L system>

Group:		5 Form:1		Life: 3000set	
#	Tool	Comp	Used(set)	ST	
1	1	2	0	0	
2	2	2	2	1	
3	5	5	5	1	
4	6	6	6	1	
5	7	7	7	1	
6	8	8	8	1	
7	9	9	9	1	
8	10	10	10	1	

3.5.2 Displaying the Life Management Data in Group Units (M system)

The tool life management data of an arbitrary group is set and displayed.

If the registered tools cannot be displayed on one screen, scroll the screen using the  or  key.

#	Tool No.	ST	Mthd	L compen	R compen
1	101	01	220	80.000	8.000
2	102	00	221	82.000	8.000
3	103	00	221	88.000	8.000
4	104	00	220	90.000	8.000
5	105	00	220	100.000	8.000
6					
7					
8					
9					
10					
11					
12					
13					
14					

#	Tool No.	Auxil	Life	Used
1	100	15	650	2000 min
2	101	0	9999	9999 set
3	102	12	5872	12 set
4	103	856	0	0 min
5				
6				
7				
8				
9				
10				
11				
12				
13				
14				

Display items (M system)

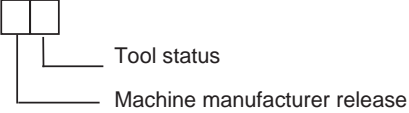
Display item	Details	Display range
(1) Group No.	This is the group No. of the tool for which tool life management is performed. Tools with the same group No. are regarded as spare tools. (Note) The group No. will not be displayed for the tool life management III.	1 to 99999999
(2) #	This is the data setting No.. This is not the magazine pot No.	
(3) Tool No.	This is the No. corresponding to the each individual tool. Maximum 1000 tools can be registered. This is a fixed tool No. actually output for the tool command and so on.	1 to 99999999
(4) ST	 <p>Tool status Machine manufacturer release</p> <p>Tool status 0 : Unused tool Normally set to "0" when the tool is replaced with a new tool. 1 : Used tool This becomes "1" when the cutting actually starts. 2 : Normal life tool This becomes "2" when the usage data (usage time and No. of uses) exceeds the life data. 3 : Tool abnormality 1 tool 4 : Tool abnormality 2 tool (Note) Item 3 and 4 differ depending on the machine tool builder specifications.</p>	

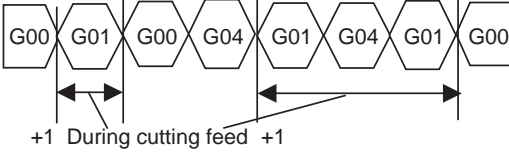
Display item	Details	Display range
(5) Mthd	 <p>(a) Tool life management method (b) Tool radius compensation data format (c) Tool length compensation data format</p> <p>(a) Tool life management method 0 : Usage time This manages by the cutting execution time. 1 : No. of mounting times This manages by the No. of times the tool became the spindle tool in tool replacement, etc. However, in the case where the cutting feed command (G01, G02, G03 etc.) is not executed even once after becoming the spindle tool, the No. of times is not counted. 2 : Usage count This is counted when the rapid traverse command (G00 etc.) is changed to the cutting feed command (G01, G02, G03 etc.). However, this is invalid in the case of a rapid traverse or cutting feed command with no movement.</p>  <p>(b) Tool radius compensation data format (c) Tool length compensation data format 0 : Compensation No. The tool life management data compensation data is handled as a compensation No., this No. replaces the compensation No. designated in the process program, and compensation is performed. 1 : Added compensation amount The tool life management data compensation data is handled as the added compensation amount, an addition is made to the compensation amount shown with the compensation No. designated in the process program, and compensation is performed. 2 : Direct compensation amount The tool life management data compensation data is handled as the direct compensation amount, this No. replaces the compensation amount shown for the compensation No. designated in the process program, and compensation is performed.</p>	
(6) L compen		Compensation No. : 1 to 400
(7) R compen	This depends on the data format designated in "Mthd".	Added compen- sation amount Direct Compen- sation amount (Note 1)
(8) Auxil	This depends on the machine tool builder specifications.	0 to 65535
(9) Life	Set the usage time (minutes), attachment count (No. of times attached to the spindle), or usage count (No. of holes drilled) for the life for each tool based on the data format set for "Method". The life is infinite when "0" is set.	Usage time: 0 to 4000 (min) No. of mounting times: 0 to 65000 (set) No. of uses: 0 to 65000 (set)

Display item	Details	Display range
(10) Used	This displays the usage data for individual tools based on the method specified for the tool life management method. (Note) This data is not counted during machine lock, auxiliary function lock, dry run or for a single block.	Usage time: 0 to 4000 (min) No. of mounting times: 0 to 65000 (set) No. of uses: 0 to 65000 (set)

(Note 1) The "Length compensation" and "Radius compensation" calculation/direct compensation amount setting/display range are as follows based on a combination of settings of "#1003 iunit (input unit)" and "#1041 I_inch (initial inch)".

#1003 iunit	#1041 I_inch	#11050 T-ofs digit type	Setting/display range
B	0	0	-999.999 to 999.999
		1	-9999.999 to 9999.999
	1	0	- 99.9999 to 99.9999
		1	- 999.9999 to 999.9999
C	0	0	-999.9999 to 999.9999
		1	-9999.9999 to 9999.9999
	1	0	- 99.99999 to 99.99999
		1	- 999.99999 to 999.99999

When data without the decimal point is input, a set unit can be specified by the parameter "#8119 Comp. unit switch".



Menus (M system)

Menu	Details	Type	Reference
Group No.	This displays the data of a group when that group No. of tool life management data is set and the [INPUT] key is pressed. The group No. can be referred to in the group list. (Note 1)	A	"Designating a group No."
Line copy	Copies one line of tool life management data where the cursor is located.	C	"Copying/pasting the tool life data"
Line paste	The copied tool life management data is written to the data in the line where the cursor is located. If the copied data is changed after the menu [Line copy] is pressed, the data before changing is written when pasted. The data in the copied line can be pasted as many times as is required until new data is copied.	C	
Line clear	This erases a designated line (multiple lines possible) of tool life management data. The first and the last line No. of the data to be erased is specified with a "/" separating the Nos. If the [INPUT] key is pressed without specifying a line, the data in the line where the cursor is located is erased.	A	"Erasing one line of tool life management data" "Designating and erasing a line"
Grp No. change	This changes a group No. If a new group No. is set and the [INPUT] key pressed, the group No. changes. An error occurs if a pre-existing group No. is set. (Note 1)	A	"Changing a group No."
Horiz scroll	This scrolls the display of the tool life management data to the left and right. The items below display alternately each time the menu is pressed. 1. Tool No., ST, Mthd, L compen, R compen 2. Tool No., Auxil, Life, Used	C	
Prev group	Displays the previous group No. data. (Note 1)	C	
Next group	Displays the next group No. data. (Note 1)	C	
Group list	This displays the list of tool life data groups. (Note 1)	C	
Group regist	This creates a new group. (Note 2)	A	"Registering a group"
Group delete	This erases all tool life management data contained in the currently displayed group No. (Note 2)	A	"Erasing a group"

(Note 1) This menu is not valid for the tool life management III.

(Note 2) This menu will not be displayed for the tool life management III.

Operation method (Designating a group No.) (M system)

- (1) Press the [Group No] menu.  The menu is highlighted.
- (2) Designate the group No. to be displayed.  The tool life data of the designated group No. appears, and the cursor moves to the head of the data.
12 [INPUT]



(Note) If a group No. that does not exist is designated, a message appears to confirm the creation of a new No. A new group is created if [Y] or [INPUT] is pressed.

Operation method (Changing a group No.) (M system)

- (1) Press the [Grp No. change] menu. → The menu is highlighted.
- (2) Designate the group No. after changing. → The group No. changes to "112".
112 [INPUT]

(Note) An error occurs if the group No. duplicates a pre-existing group No.

Operation method (Setting the tool life data) (M system)

- (1) Move the cursor to the data to be set using the , , [↑], [↓], [←] and [→] keys. → The menu is highlighted.
It is possible to move to the line after the registered line.
Set a tool No. for this line to newly register tool life management data.
- (2) Set a value. → The set value displays.
20 [INPUT] → The cursor moves one position to the right.

(Note 1) The other settings will be invalid when the tool ST (status) setting data are not set.

(Note 2) The same tool cannot be registered in more than one group.

(Note 3) If the tool No. is not set, the other data cannot be set.

(Note 4) Change the "Method" to initialize the related items.

Change the tool life management method (the 1st digit) to clear the "Life" and "Usage", and also change the units.

Change the tool radius compensation data (the 2nd digit) to clear the "Radius Compensation".

Change the tool length compensation data (the 3rd digit) to clear the "Length Compensation".

Figures after the decimal point are also changed in line with the specifications.



Operation method (Copying/pasting the tool life data) (M system)

- (1) Move the cursor to the line to be copied.
- (2) Press the menu [Line copy]. → The menu is highlighted.
The background color of the copied data changes to light blue.
(The color changes even when scrolling horizontally.)
- (3) Move the cursor to the line where the data is to be pasted. →
- | # | Tool No. | ST | Mthd | L compen | R compen |
|---|----------|----|------|-------------|-------------|
| 1 | 87654321 | 0 | 110 | -123456.789 | -123456.789 |
| 2 | 101 | 1 | 101 | 123.456 | 123 |
| 3 | 102 | 2 | 012 | 100 | 123.456 |
| 4 | 103 | 3 | 020 | 1 | -123.456 |
| 5 | | | | | |
- (4) Press the [Line paste] menu. → The copied tool life management data is written to the data (excluding the tool No.) in the line where the cursor is located.
The background color returns to normal.
The cursor moves to "ST".



(Note 1) Once copied, the data is held until a new data item is copied.

(Note 2) It is not possible to paste into a line for which a tool No. has not been set.

Operation method (Erasing one line of tool life management data) (M system)

- (1) Move the cursor to the line to be erased.
- (2) Press the menu [Line clear] and [INPUT] keys.  The menu is highlighted.
A message displays confirming whether it is okay to erase the data.
The background color of the area to be erased changes to light blue.
- (3) Press the [Y] or [INPUT] key.  One line of the selected life management data is erased and the menu highlight returns to normal.
The next line moves up after erasing.
Press a key other than [Y] or [INPUT] in order not to erase the data.

Operation method (Designating and erasing the multiple lines) (M system)



- (1) Press the menu [Line clear].  The menu is highlighted.
- (2) Set the range to be erased by marking the first and last # Nos. with a "/", and press [INPUT] key.  A message appears to confirm the erasing.
The background color of the area to be erased changes to light blue.
122/125 [INPUT]
- (3) Press the [Y] or [INPUT] key.  The tool life data corresponding to the designated # No. is erased, and the menu highlight returns to normal.
The next line after the erased range moves up.
Press a key other than [Y] or [INPUT] in order not to erase the data.

Operation method (Registering a group) (M system)



- (1) Press the [Group regist] menu.
- (2) Set the No. of the group to be registered.  A new group is created and the life management data displays containing no data.
25 [INPUT]

(Note 1) An error occurs if the same group No. already exists.
 (Note 2) The group is not registered if one of the operations below is performed after registering a new group No..
 - If the application is exited without registering even 1 item of tool life data.
 - If the screen is changed to that of other than the group unit display.

Operation method (Erasing a group) (M system)

- (1) Move the cursor to the group No. to be erased.
- (2) Press the [Group delete] menu.  A message appears to confirm the erasing.
- (3) Press the [Y] or [INPUT] key.  All the tool life management data for the displayed group No. is erased and the previous group No. data displays.
Returns to the group list displays if all groups are erased.

3.5.3 Displaying the Life Management Data (L system: Tool life management I)

The tool life management data can be set and displayed. Use the / keys to scroll between screens if all of the registered tools cannot be displayed on one screen.

#	[Time]		[Count]		[Status]	
	Used	Life	Used	Life	A	B
1	46:36:12	0: 0	3000	0	0	0
2	46:47: 7	0: 0	3000	0	2	0
3	46:47: 7	0: 0	3000	0	5	0
4	46:47: 7	0: 0	3000	0	6	0
5	46:47: 7	0: 0	3000	0	7	0
6	46:47: 7	0: 0	3000	0	8	0
7	46:47: 7	0: 0	3000	0	9	0
8	46:47: 7	0: 0	3000	0	10	0
9	0:21:51	0: 0	3232	0	-95	12
10	0: 0: 0	0: 0	0	0	0	0
11	0: 0: 0	0: 0	0	0	0	0
12	0: 0: 0	0: 0	0	0	0	0
13	0: 0: 0	0: 0	0	0	0	0



Display items (L system)

Display item		Details	Display range
(1)	#	Tool No. The # No. is highlighted if the usage time reaches the life time or if the usage count exceeds the life count.	
(2)	Time	Used The integrated time the tool is used. This timer value is incremented during cutting.	0:0:0 to 99:59:59 (h:min:s)
		Life Tool life time Set the service lifetime.	0:0 to 99:59(h:min) (0:0 = no warning given)
(3)	Count	Used The integrated count the tool is used. The count goes up when a tool is selected.	0 to 65000(times)
		Life Tool life count Set the service life count.	0 to 65000 (times) (0:0 = no warning given)
(4)	Status	A (left side) 0: Not used 1: Current tool (tool being used) 2: Service lifetime (service life count) is exceeded.	0 to 2
		B (right side) (Used by machine tool builder)	0 to 99

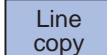
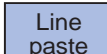
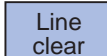

Menus (L system)

Menu	Details	Type	Reference
	Copies one line of tool life management data where the cursor is located.	C	"Copying/pasting the tool life data"
	The copied tool life management data is written to the data in the line where the cursor is located. If the copied data is changed after the menu key [Line copy] is pressed, the data before changing is written when pasted. The copied data can be pasted as many times as is required until new data is copied.	C	
	This erases a designated line (multiple lines possible) of tool life management data. The first and the last line No. of the data to be erased is specified with a "/" separating the Nos.. If the [INPUT] key is pressed without specifying a line, the data in the line where the cursor is located is erased.	A	

Operation method (Setting the tool life data) (L system)



- (1) Move the cursor to the data to be set using the , , [↑], [↓], [←] and [→] keys.
It is possible to move to the line after the registered line.
- (2) Set a value.
20 [INPUT]  The set value displays.
The cursor moves one position to the right.

Operation method (Copying/pasting the tool life data) (L system)



- (1) Move the cursor to the line to be copied.
- (2) Press the menu [Line copy].  The background color of the copied data changes to light blue.
- (3) Move the cursor to the line where the data is to be pasted.
- (4) Press the [Line paste] menu.  The copied tool life management data is written to the data in the line where the cursor is located.
The background color returns to normal.

(Note 1) Once copied, the data is held until a new data item is copied.

Operation method (Erasing one line of tool life management data) (L system)

- (1) Move the cursor to the line to be erased.
 - (2) Press the menu [Line clear] and [INPUT] keys.  The menu is highlighted.
A message displays confirming whether it is okay to erase the data.
The background color of the area to be erased changes to light blue.
 - (3) Press the [Y] or [INPUT] key.  One line of the selected life management data is erased and the menu highlight returns to normal.
The next line moves up after erasing.
- Press a key other than [Y] or [INPUT] in order not to erase the data.



Operation method (Designating and erasing the multiple lines) (L system)

- (1) Press the menu [Line clear].  The menu is highlighted.
- (2) Set the erasing range by marking the first and last # Nos. with a "/", and press [INPUT] key.
122/125 [INPUT]  A message displays confirming whether it is okay to erase the data.
The background color of the area where the data is erased changes to light blue.
- (3) Press the [Y] or [INPUT] key.  The tool life data corresponding to the designated # No. is erased, and the menu highlight returns to normal.
The next line after the erased range moves up.

(Note) If the [INPUT] key is pressed without setting a # No., the line at the cursor is erased.

3.5.4 Displaying the Tool Life Management Data in Group Units (L system: Tool life Management II)

The tool life management data of an arbitrary group is set and displayed.

If the registered tools cannot be displayed on one screen, scroll the screen using the  or  key.

This screen is enabled only for tool life management II ("#1096 T_Ltyp" = 2).

Group: 1		Form: 1	Life: 300 (set)
#	Tool	Comp	Used (set) ST
1	101	11	28 1
2	102	12	0 0
3	103	13	0 0
4	104	14	0 2
5	105	15	0 0
6			
7			
8			

By setting parameter "#1107 Tllfsc", it is possible to select the life management data display mode for multiple groups.

"#1107 Tllfsc" setting value	0	1	2
No. of display groups	1	2	4
Max. No. of registered tools	16	8	4

<Group 1 display mode> (#1107 Tllfsc = 0)

Group: 1		Form: 1	Life: 300 (set)				
#	Tool	Comp	Used (set) ST	#	Tool	Comp	Used (set) ST
1	101	11	28 1	9			
2	102	12	0 0	10			
3	103	13	0 0	11			
4	104	14	0 2	12			
5	105	15	0 0	13			
6				14			
7				15			
8				16			

<Group 2 display mode> (#1107 Tllfsc = 1)

Group: 1		Form: 1	Life: 300 (set)	Group: 2		Form: 1	Life: 200 (set)
#	Tool	Comp	Used (set) ST	#	Tool	Comp	Used (set) ST
1	101	11	28 1	1	201	21	11 1
2	102	12	0 0	2	202	22	0 0
3	103	13	0 0	3	203	23	0 0
4	104	14	0 2	4			
5	105	15	0 0	5			
6				6			
7				7			
8				8			

<Group 4 display mode> (#1107 TlIfsc = 2)

Group: 1 Form: 1 Life: 300 (set)					Group: 2 Form: 1 Life: 200 (set)				
#	Tool	Comp	Used (set)	ST	#	Tool	Comp	Used (set)	ST
1	101	11	28	1	1	201	21	11	1
2	102	12	0	0	2	202	22	0	0
3	103	13	0	0	3	203	23	0	0
4	104	14	0	2	4				

Group: 3 Form: 0 Life: 30 s					Group: 4 Form: 0 Life: 50 s				
#	Tool	Comp	Used (s)	ST	#	Tool	Comp	Used (s)	ST
1	301	31	5	1	1	401	41	5	1
2	302	32	0	0	2	402	42	0	0
3	303	33	0	0	3	403	43	0	0
4					4				

Display items (L system)

<Group information>

Display item	Details	Setting range
(1) Group	Life management group No.	1 to 9999
(2) Form	This displays whether to control the currently displayed group in usage hours or usage count.	0 : Hours 1 : Times
(3) Life	This sets the tool life data for the currently displayed group. The following tool life data units display based on the control method. Usage time: (s) Usage count: (set)	Usage time: 0 to 99999999 (s) Usage count: 0 to 999999 (set)



<Life management data within group>

Display item	Details	Setting range
(4) #	This displays whether the tool for which the # No. is highlighted is a life tool (ST=2) or a skip tool (ST=3).	
(5) Tool No.	This sets the tool No.	1 to 999999
(6) Comp No.	This sets the compensation No.	1 to 80
(7) Used	This sets the usage data at such times as when the tool is not an unused tool. This becomes "0" when the usage data is not set. The following usage data units display based on the control method. Usage time: (s) Usage count: (set)	Usage time: 0 to 99999999 (s) Usage count: 0 to 999999 (set) Setting can be omitted.
(8) ST	This sets the tool status. This becomes "0" when the tool status is not set. 0: Unused tool 1: Used tool 2: Normal life tool 3: Skipped tool	0 to 3 Setting can be omitted.

Menus (L system)



Menu	Details	Type	Reference
Group No.	This displays the data of a group when that group No. of tool life management data is set and the [INPUT] key is pressed. The group No. can be referred to in the group list.	A	"Designating a group No."
Line copy	Copies one line of tool life management data where the cursor is located.	C	"Copying/pasting the tool life data"
Line paste	The copied tool life management data is written to the data in the line where the cursor is located. If the copied data is changed after the menu key [Line copy] is pressed, the data before changing is written when pasted. The copied data can be pasted as many times as is required until new data is copied.	B	
Line clear	This erases a designated line (multiple lines possible) of tool life management data. The first line No. and the last line No. of the data to be erased is specified with a "/" separating the Nos. If the [INPUT] key is pressed without specifying a line, the data in the line where the cursor is located is erased.	A	"Erasing one line of tool life management data" "Designating and erasing a line"
Grp No. change	This changes a group No. If a new group No. is specified and the [INPUT] key pressed, the group No. changes. An error occurs if a pre-existing group No. is set.	A	"Changing a group No."
Group change	The group active area is changed if parameter "#1107 TlIfsc" is set to 1 or 2.	C	"Changing the active area for multiple group displays"
Multi group	Changes to the multiple group life management data display mode based on the parameter "#1107 TlIfsc" setting value.	C	
Group regist	This creates a new group and displays the life management data containing no data.	A	"Registering a group"
Group list	This displays the list of tool life data groups.	C	
Close	The multiple group life management data display mode is cancelled.	C	

Operation method (Designating a group No.) (L system)

- (1) Press the [Group No.] menu.  The menu is highlighted.
- (2) Designate the group No. to be displayed.
12 [INPUT]  The tool life data of the designated group No. appears, and the cursor moves to the head of the data.



(Note) If a group No. that does not exist is set, a message appears to confirm the creation of a new No.. A new group is created if [Y] or [INPUT] is pressed.
When creating a new group, set the method and life data at the end of the group No., separating the data with a "/". If the method and life data are omitted, a new group is created with method = 0 (usage time), and life data = 0.

Operation method (Changing a group No.) (L system)

- (1) Press the [Grp No. change] menu.  The menu is highlighted.
- (2) Designate the group No. after changing.
112 [INPUT]  The group No. changes to "112".



(Note) An error occurs if the group No. duplicates a pre-existing group No.

Operation method (Setting the tool life data) (L system)

- (1) Move the cursor to the data to be set using the , , [↑], [↓], [←] and [→] keys.
It is possible to move to the line after the registered line.
Set a tool No. for this line to newly register tool life management data.
- (2) Set a value.
20 [INPUT]  The set value displays.
The cursor moves one position to the right.



(Note 1) It is not possible to set any other data if the tool No. and compensation No. have not been set.

Operation method (Copying/pasting the tool life data) (L system)

- (1) Move the cursor to the line to be copied.
- (2) Press the menu [Line copy].  The background color of the copied data changes to light blue.
- (3) Move the cursor to the line where the data is to be pasted.
- (4) Press the [Line paste] menu.  The copied tool life management data is written to the data in the line where the cursor is located.
The background color returns to normal.
The cursor moves to "Tool No.".



(Note 1) Once copied, the data is held until a new data item is copied.

Operation method (Erasing one line of tool life management data) (L system)

- (1) Move the cursor to the line to be erased.
- (2) Press the menu [Line clear] and [INPUT] keys.  The menu is highlighted.
A message displays confirming whether it is okay to erase the data.
The background color of the area where the data is erased changes to light blue.
- (3) Press the [Y] or [INPUT] key.  One line of the selected life management data is erased and the menu highlight returns to normal.
The next line moves up after erasing.

Press a key other than [Y] or [INPUT] in order not to erase the data.

Operation method (Designating and erasing the multiple lines) (L system)

- (1) Press the menu [Line clear].  The menu is highlighted.
- (2) Set the erasing range by marking the first and last # Nos. with a "/", and press [INPUT] key. 1/5 [INPUT]  A message displays confirming whether it is okay to erase the data. The background color of the area where the data is erased changes to light blue.
- (3) Press the [Y] or [INPUT] key. Press a key other than [Y] or [INPUT] in order not to erase the data.  The tool life data corresponding to the designated # No. is erased, and the menu highlight returns to normal. The next line after the erased range moves up.

(Note) If the [INPUT] key is pressed without setting a # No., the line at the cursor is erased.

Operation method (Registering a group) (L system)

- (1) Press the [Group regist] menu.
- (2) Set the No. of the group to be registered. 25/1/3000 [INPUT]  A new group is created and the life management data displays containing no data.

(Note 1) If the method and life data are omitted, a new group is created with method = 0 (usage time), and life data = 0.

(Note 2) An error occurs if the same group No. already exists.

- (Note 3) The group is not registered if one of the operations below is performed after registering a new group No.
- If the application is exited without registering even 1 item of tool life data.
 - If the screen is changed to that of other than the group unit display.

Operation method (Changing the active area for multiple group displays) (L system)

- (1) Press the [Group change] menu.  The cursor indicating the active status moves to the next group.

Group: 1 Form: 1 Life: 300 (set)					Group: 2 Form: 1 Life: 200 (set)				
#	Tool	Comp	Used (set)	ST	#	Tool	Comp	Used (set)	ST
1	101	11	28	1	1	201	21	11	1
2	102	12	0	0	2	202	22	0	0
3	103	13	0	0	3	203	23	0	0
4	104	14	0	2	4				
5	105	15	0	0	5				
6					6				
7					7				
8					8				

3.6 Workpiece Coordinate System Offset



This function allows the user to set and display the coordinate system offset controlled by the NC.

6 sets of standard workpiece coordinate system offset and 48 sets of extended work coordinate offset can be used.

(Note 1) The G92/G52 coordinate system offset cannot be set.

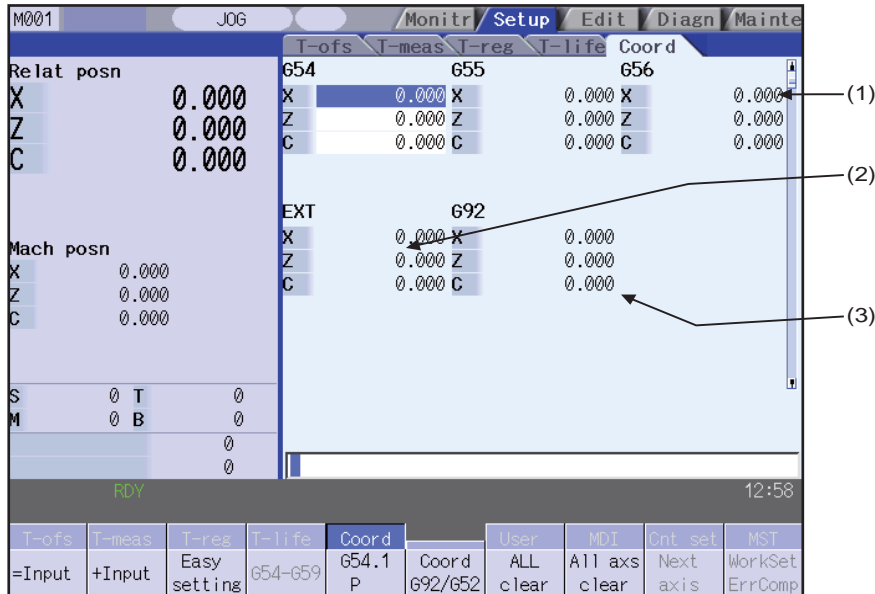

Inputting an address key, such as MST, displays manual numerical value command window where manual numerical value command is executed.

Display items

Display item	Details
(1) Coordinate system offset area	<p>This sets and displays the offset amount for the workpiece coordinate system (G54 - G59), or the extension workpiece coordinate system (G54.1Pn). Use the menu operation or page change key to specify which workpiece coordinate system offset to display or set. The workpiece coordinate system offset amount data can be set in absolute or additional mode.</p>
(2) EXT offset area	This displays or sets the offset amount for the external workpiece system.
(3) G92/G52 offset area	This displays the offset amount for G92 or the local coordinate system. The offset amount of the corresponding local coordinate system (G52) is displayed only when the cursor is at G54 to G59.

CAUTION









If the tool compensation amount or workpiece coordinate system offset amount is changed during automatic operation (including during single block stop), the changes will be valid from the command in next block or after several subsequent blocks.

Menus

Menu	Details	Type	Reference
=Input	This inputs the offset amount with the absolute mode. When "#8929 Disable=INPUT:comp" is set to "1", this menu cannot be selected.	C	3.6.1 Setting the Coordinate System Offset
+Input	This inputs the offset amount with the additional mode.	C	
Easy setting	This sets the workpiece coordinate system offset so that the current machine coordinate becomes the workpiece coordinate zero point. Only the axis at the cursor position is set. When "#8935 W COORD CONFIRM" is set to "1", a operation message is displayed, and the menu is highlighted. Easy setting cannot be executed for an axis of auxiliary axis state.	A/C	3.6.3 Setting the Work Piece Coordinate Origin
G54-G59	This displays the G54 - G59 workpiece coordinate system offset amount. The cursor moves to the G54 offset. This menu can be used when the G54 - G59 offsets are not displayed.	C	3.6.1 Setting the Coordinate System Offset
G54.1 P	Enter the P number displayed at the screen to display the extension workpiece coordinate (G54.1 Pn) offset in the coordinate system offset area. If the local coordinate system offset (G52) displays in the G92/G52 area, the display changes to G92.	A	
Coord G92/G52	This displays the G92 or G52 coordinate system offset amount. The G92 offset data is always displayed when the cursor is not at the G54 to G59 offset data.	C	
All clear	All coordinate system offset amounts for all axes are erased with the exception of G92 and EXT.	A	3.6.2 Erasing the Coordinate System Offset Amount
All axs clear	This erases the local offset data for all axes corresponding to the offset data of the coordinate system where the cursor is located.	A	
Next Ax	In E70 series, this menu cannot be selected.		
WorkSet ErrComp	In E70 series, this menu cannot be selected.		

3.6.1 Setting the Coordinate System Offset Amount

Operation method (Setting the workpiece coordinate system G54 - G59 offset amount)

- (1) Press the [G54-G59] menu.  The G54 - G59 workpiece coordinate system offset displays.
- (2) Use the ( ) keys to move the cursor to the workpiece coordinate system offset to be set.
Use the  ,  page keys to change the coordinate system display.
Refer to the "Changing the offset amount using the page change keys (previous page:  , next page: )" section in "3.6.4 Changing the coordinate system display" for further details.
- (3) Use the [↑], [↓] keys to move the cursor to the axis for which data is to be set.
- (4) Set the offset amount.  The set data displays and the cursor moves to the next data.
122 [INPUT]
This setting can be made by pressing the menu [=INPUT] key instead of the [INPUT] key.
- (5) Set other data using the same method.



(Note) It is possible to perform additional input by pressing the menu [+INPUT] key instead of the [INPUT] or menu [=INPUT] keys.
[Ex.] If the original data is 122.000:
1.234 [+INPUT] 122.000 + 1.234 = 123.234

Setting the external coordinate system offset amount



Set the external coordinate system offset amount to keep the current workpiece coordinate system offset amounts from G54 to G59, and also apply an offset to the entire system.
Furthermore, it is also possible to use the data transfer function to write data directly to the external coordinate system offset (EXT).
(Refer to "6.2 Input/output screen" for details of the data transfer function.)

3.6.2 Erasing the Coordinate System Offset Amount

Operation method (Erasing the coordinate system (excluding G92) offset amount where the cursor is displayed for all axes.)

- (1) Press the menu [All axcs clear] menu.  Press the menu [All axcs clear] menu.
- (2) Press the [Y] key.  All of the coordinate system indicated by the cursor is cleared to zero.
In addition, all axes data of the local offset (G52) for the coordinate system will be erased.

Operation method (Erasing all axis offset data of all coordinate systems (excluding G92 and EXT))

- (1) Press the menu [All clear] menu.  The menu is highlighted.
A message displays confirming whether it is okay to erase the data.
- (2) Press the [Y] key.  All coordinate system data is erased.
In addition, all axes data of the local offset (G52) for the G54 to G59 coordinate systems will be erased.



(Note) G92 data cannot be erased.

3.6.3 Setting the Workpiece Coordinate Origin

Press the menu [Easy setting] key to set the coordinate system offset so that the current machine position (for all axes) becomes the workpiece coordinate origin. It is only possible to set those axes where the cursor is located.



If the menu [Easy setting] is pressed when there is the cursor in coordinate system offset (G54 to G59), the local offset (G52) data of the axis will be also erased.

3.6.4 Changing the Coordinate System Display

Use the   tab keys to change the coordinate system offset cursor position.

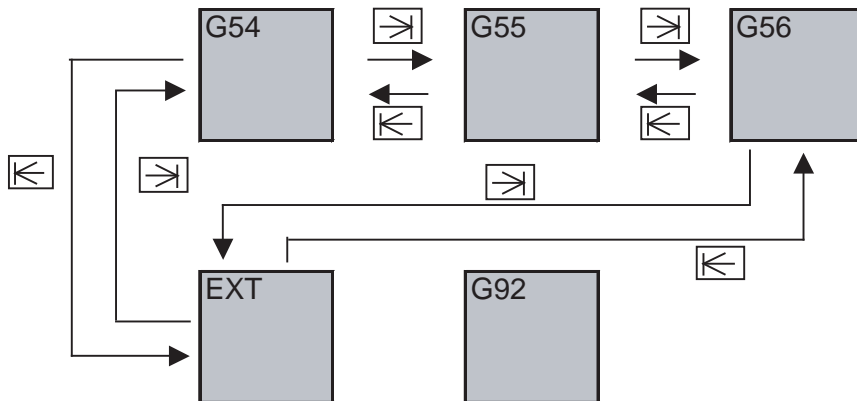
Press the Tab key to change the cursor position.



Changing the coordinate system offset using the page change keys (previous page: , next page: )

Use the page change keys to change the coordinate system offset display as shown below.

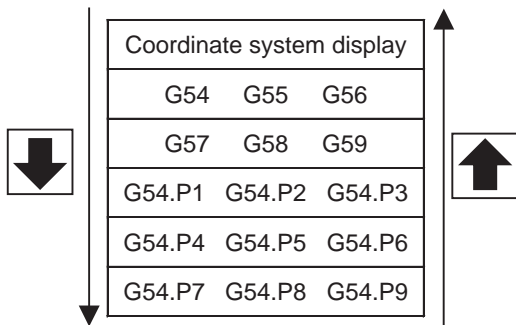

3.7 User Parameters



The parameters contain the user and machine parameters.
 This chapter explains the details and operations for the user parameters.
 Refer to "Appendix 10 User Parameter List" for details of each parameter.

<Process parameter>: The E70 series is one-part system control.

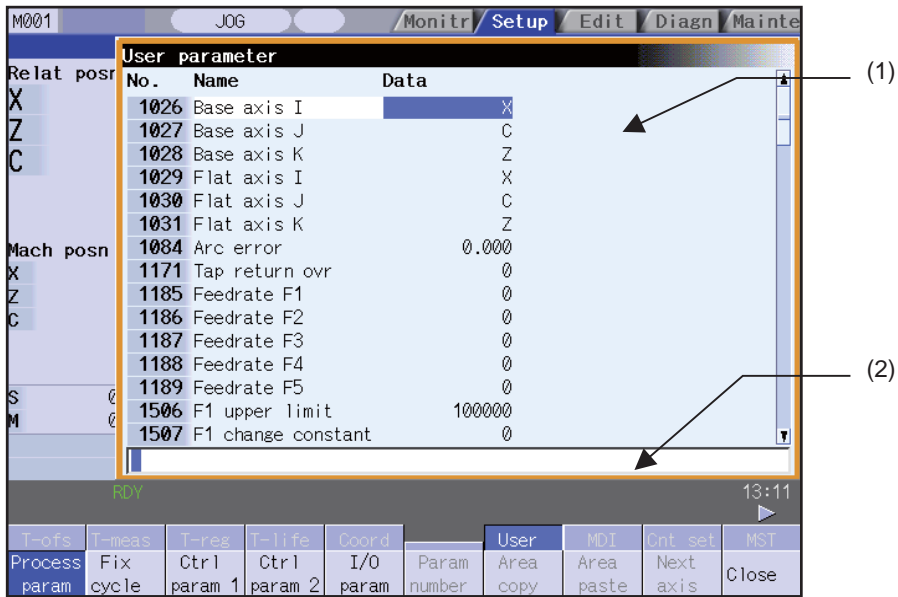

<Axis parameter>: Axis based

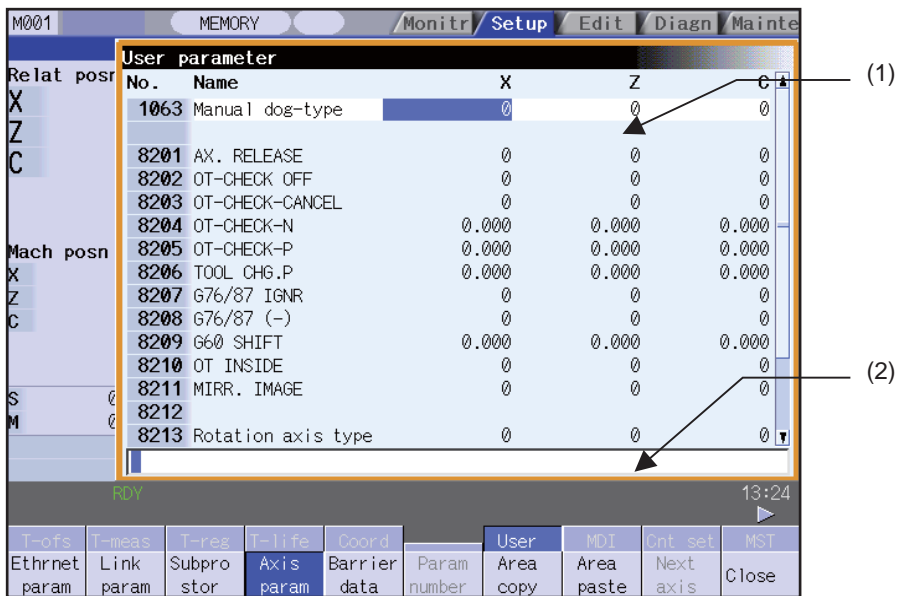

Display items

Display item	Details
(1) Parameter display area	Press the parameter selection menu [Process param] or [Axis param] keys etc. to change the parameter display contents.
(2) Input section	The set key displays. Press the [INPUT] key to set the display data in the parameter where the cursor is located.



Menus

Menu	Details	Type	Reference
Process param	This changes the display of each parameter type. (Note 1) The barrier data only displays for the L system. (Note 2) "Hi-prec param" and "Hi-prec axis" are not available.	B	3.7.1 Setting the Parameters
Fixed cycle			
Ctrl param 1			
Ctrl param 2			
I/O param			
Ethernet param			
Link param			
Subprocessor			
Axis param			
Barrier data			
Hi-prec param			
Hi-prec axis			
Operate param			
Menu select			
Param No.	In E70 series, this menu cannot be selected.		
Area copy	This copies the parameter setting values in the designated range. The range is designated with numbers.	A	3.7.3 Copying/Pasting Parameters
Area paste	This pastes the range of parameters designated in area copy. They are pasted in a parameter corresponding to the axis where the cursor is. Once copied, a parameter can be pasted any number of times until a new parameter is copied.	A	
Next Ax	This can be selected if the total number display axes is 4 or more. This is used at the parameter screen with the array structure for each axis.	C	
Close	This closes the pop-up window and quits this function.	C	



3.7.1 Setting the Parameters

The method of setting the parameters is explained. Refer to "Appendix 10 User Parameter List" for details of each parameter setting range.

Operation method (Normal setting: Set "100" for X1 axis of "#8204 OT-" parameter)

- (1) Press the [Axis param] menu.  The axis parameter displays.
- (2) Use the [↑], [↓], [←] and [→] keys to move the cursor to the setting position.  The cursor moves to the position where the data is to be set (X1 axis).
- (3) Enter a value.  The set value displays and the cursor moves one position downwards.
100 [INPUT]

Operation method (Batch data setting: Set "200" for Y1 axis and "250" for Z1 axis of "#8204 OT-")

- (1) Press the [Axis param] menu.  The axis parameter displays.
- (2) Use the [↑], [↓] keys to move the cursor to the setting position.  The cursor moves to the position where the data is to be set.
- (3) Enter a value.  The set value displays and the cursor moves one position downwards.
Input format:
1st column/2nd column/3rd column
/200 /250 [INPUT]

(Note 1) When a parameter is changed and [PR] displays at the top of the screen, reboot the machine to enable that parameter change.

(Note 2) When the [INPUT] key is pressed without inputting a value, the parameter setting value is not changed, and the cursor moves.



(Note 3) Parameters that can be set simultaneously must display within the currently displayed three columns.

(Note 4) If parameter values are simultaneously input in multiple columns, settings are made from the currently displayed column on the left side, no matter which column the cursor is positioned.

3.7.2 Copying/Pasting Parameters

Parameters can be copied and pasted in a parameter with the same number for another axis or part system.

Operation method (Specifying and copying the parameter where the cursor is located)

- (1) Press the [Area copy] menu.  The menu is highlighted.
- (2) Move the cursor to the position of the parameter to be copied and press the [INPUT] key.  The copy position displays in the selected area color. The menu highlight returns to normal.

Operation method (Copying parameter numbers in a specific range)

(1) Move the cursor to the display area of the axis or part system to be copied.

(2) Press the [Area copy] menu.



The menu is highlighted.

(3) Designate the copy range.



The range to be copied displays in the selected area color. The menu highlight returns to normal.

Format: First No./Last No.

8701/8705 [INPUT]

An "E" can be used if the last number to be copied is the last number in the currently displayed parameter type.

(Ex.) 8701/E

No.	Name	Data
	<TLM>	
8701	Tool Length	100.000
8702	Tool Dia	0.000
8703	OFFSET X	5.000
8704	OFFSET Y	10.000
8705	RETURN	5.000
8706	FEED	100
8707	Skip past amount(H)	0.000

(Note 1) The selected area color of the copied area returns to normal when the copied data is pasted. However, the copied range can still be pasted until the parameter type display is changed.

(Note 2) Only the currently displayed parameter type can be copied.

Operation method (Pasting the copied parameters)

(1) Move the cursor to the axis or part system display area where the data will be pasted.

(2) Press the [Area paste] menu.



The menu is highlighted and a confirmation message displays.

(3) Press the [Y] or [INPUT] key.



The copied data is written to the parameter where the cursor is located.

The copied data is not written in when the [N] key is pressed.

The menu highlighted returns to normal.

(Note) If the relevant parameter is changed after specifying the range to be copied, the value after the change is pasted.

3.7.3 Parameter Configuration

The parameter number range and permissible operations for all parameter types are shown below.

○ : Can be used, △ : Operable under certain conditions (Refer to the section below for conditions.)

Parameter type	[Next axis] menu	[Area copy] menu	[Area paste] menu
Process parameter	-	-	-
Fixed cycle	-	-	-
Control parameter 1	-	-	-
Control parameter 2	-	-	-
I/O parameter	-	-	-
Ethernet parameter	-	-	-
Computer link parameter	-	-	-
Subprogram storage designation parameter	-	-	-
Axis parameter	△ (Note 1)	△ (Note 2)	△ (Note 2)
Barrier data (Note 3)	-	○	○
Operation parameter	-	-	-

(Note 1) This is valid only when the total number of valid NC axes and PLC axes is four or more.

(Note 2) This is valid only when the total number of valid NC axes and PLC axes is two or more.

(Note 3) The barrier data appears only for the L system specifications.

3.7.4 Echoback

When the cursor moves to a parameter with 14 or more characters, all of the set value is echoed back to the input area. The value of such parameter is displayed with "..." displays in the data field.

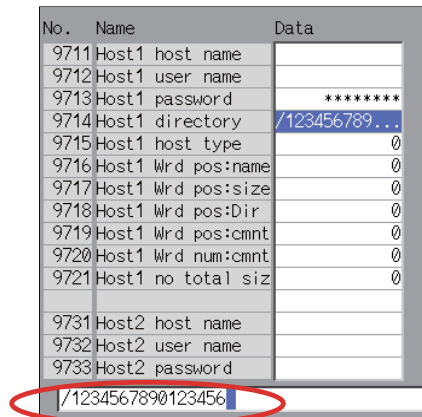

3.7.5 Ethernet Parameter Password

If the Ethernet parameter "Host 1 password" to "Host 4 password" is set, "*****" displays regardless of the password characters set in that data field.

3.8 MDI Program Editing



Press the main menu [MDI] key to display the contents of the MDI program in a pop-up window.

When the parameter "#1144 mdlkof" is "0" (MDI setting impossible), switch to the MDI mode once to press the menu [MDI].

Refer to "4.2 Program Editing" for further details.

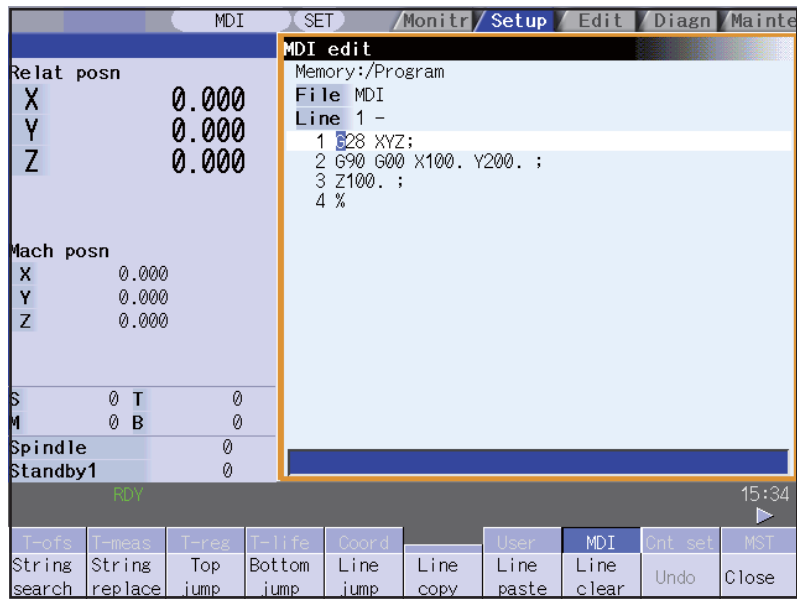



3.10 Manual Numerical Value Commands

This function is used to set and display all the Spindle function (S), Miscellaneous function (M), Tool function (T), and No. 2 miscellaneous function (B) commands.

Input the address for S, M, T, and B to set and display the manual numerical value commands.

Refer to "2.12 Manual Numerical Value Commands" for further details.

MSTB		T-ofs				
		T-meas	T-reg	T-life	Coord	
Re	S	Abs	Length	L wear	Radius	R wear
X	3300	1	0.000	0.000	10.000	0.000
Y	3	2	0.000	0.000	0.000	0.000
Z		3	0.000	0.000	0.000	0.000
		4	0.000	0.000	0.000	0.000
		5	0.000	0.000	0.000	0.000
		6	0.000	0.000	0.000	0.000
		7	0.000	0.000	0.000	0.000
Mac		8	0.000	0.000	0.000	0.000
X		9	0.000	0.000	0.000	0.000
Y		10	0.000	0.000	0.000	0.000
Z		11	0.000	0.000	0.000	0.000
		12	0.000	0.000	0.000	0.000
		13	0.000	0.000	0.000	0.000
S		14	0.000	0.000	0.000	0.000
M		15	0.000	0.000	0.000	0.000
Sp						
Sta						

RDY 10:32

T-ofs T-meas T-reg T-life Coord User MDI Cnt set MST Close

3.11 T Code List



This function searches the T code in designated machining program (including the subprograms) and lists it in the order the T codes are commanded. (Max. 100 codes)

As for the T code of the tool that has not been registered, it is indicated with text color and background color changed.

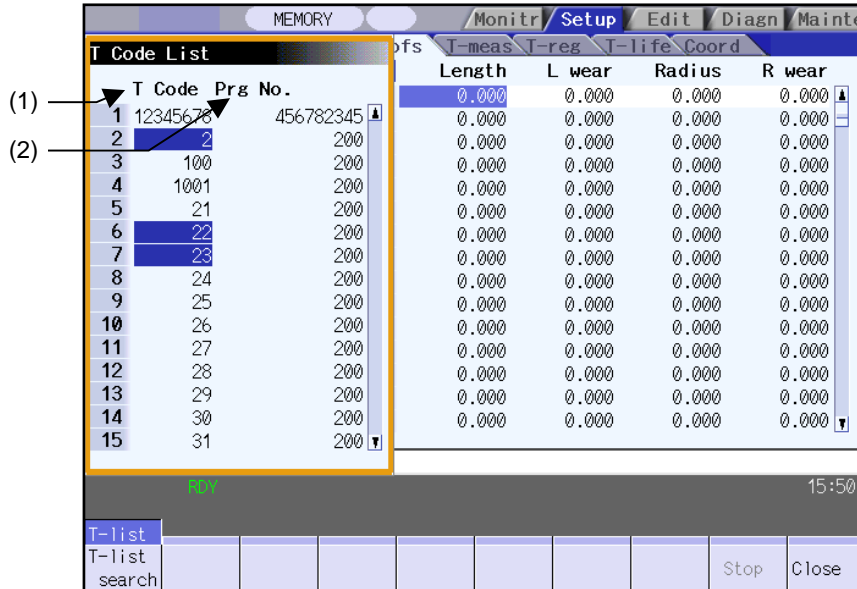

Display items

Display item	Details
(1) T code	T codes are listed in the order that the T code is commanded in the designated machining program (including subprogram). As for the T code of the tool that has not been registered, it is indicated with text color and background color changed.
(2) Program No.	This shows designated program No. When the number of characters exceeds 15, the excess is indicated as "***".

Menus (T code list display window)

Menu	Details	Type	Reference
T-list search	This displays T code list search window. This menu is invalid while getting the T codes.	C	
Halt	This interrupts getting the T codes. This menu is valid only while getting the T codes.	C	
Close	This closes the pop-up window and quits this function.	C	

Menus (T code list search window)

Menu	Details	Type	Reference
Memory	This selects the device for searching for the program to get T codes.	C	
Memory card	When a device with directory is selected, the root directory is selected first.	C	
Top jump	Display starts from the first page of the directory/list of files. The cursor moves to the top line.	C	
Bottom jump	The last page of the directory/list of files is displayed. The cursor moves to the bottom line	C	
Comment nondisp	This changes whether to show or hide the comment field in the list. When the comment field is hidden, the file name field will be enlarged.	B	2.2.2 Changing Whether to Show or Hide the Comment Field
List update	This updates the list contents. (The latest contents of the currently selected device and directory are listed.)	C	
Sort change	This changes the method that the list is sorted.	C	2.2.3 Changing the Sorting Method
Retn	This closes the pop-up window and starts getting T codes.	C	

Operation method (Display the T code list)

- | | | |
|--|---|--|
| (1) Press the menu [T-list]. | ➡ | The menu appears.
The T code list created last appears as a pop-up window. The [Halt] menu becomes invalid. |
| (2) Press the menu [T-list search]. | ➡ | The submenu appears. The list to select a file appears as a pop-up window. |
| (3) Select the device.
[EX.] HD | ➡ | The selected device name and its root directory (HD:/) appears in the directory display area. |
| (4) Use the [↑], [↓], [⬆], [⬇] keys to align the cursor with the directory of target machining program, and press [INPUT]. | ➡ | T code list appears as a pop-up window.
Getting T code and listing starts.
The [Halt] menu becomes valid.
The [T-list search] is invalid. |

T code list cannot be displayed when [INPUT] key is pressed with the following programs selected;

- The program that does not exist.
- The program that is waiting to be restarted.
- The program during automatic operation.
- The program being checked.

The list window will not change.

(Note 1) When switching to the other screen, getting T code is interrupted automatically.

(Note 2) When the [Close] menu is pressed, getting T code is interrupted automatically.

(Note 3) T code list for MDI program cannot be displayed.

(Note 4) T code list acquisition is not possible for a program with 33 or more program name characters.

(Note 5) There is a model which cannot get T code list at the manual operation mode. Switch to the automatic operation mode when T code list cannot be gotten.

(Note6) When designating program which causes program errors, researched T codes in the previous block will be displayed. T codes in the block with program errors are not be listed. Also, error message is not be displayed.

4

Edit Screens

The Edit screen is used to edit the machining program (adding, erasing and changing), perform checks, and input/output data.

4.1 Screen Configuration

The Edit screen is configured as shown below.

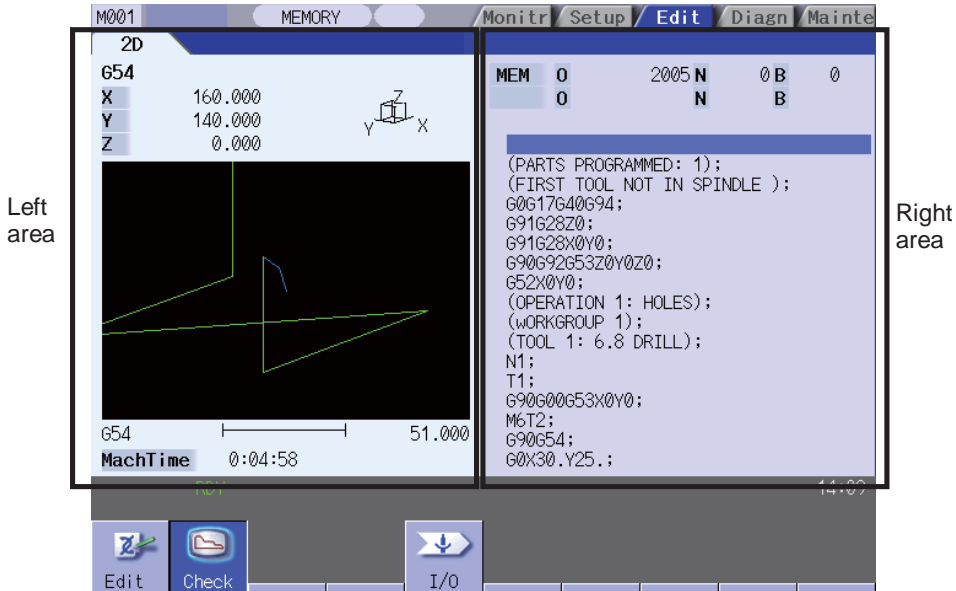



Left area :The contents differ depending on the display type.

Use the [Display change] menu   to switch the display type

Right area: Displays the program searched to be edited.

When the multi-program display type is applied, use [<--> change] menu key to switch the active area.

Menus

Menu	Details	Reference
 Edit	This edits the machining program.	4.2 Program Editing
 Check	This checks the program. This is used to check the machining program without performing automatic operation. (1)Program check (2D)This displays a graphic drawing of the machining program movement path.	4.3 Program Check (2D)
 I/O	This performs the machining program input and output between the NC internal memory and the external input/output device. (Note) When "#8923 Hide Edit-IO menu" is "1", this menu is not displayed.	4.4 Program Input/Output

4.2 Program Editing



This is used to edit (add, erase, change) the machining programs in the NC memory, memory card (CF card) or USB memory and to create new programs.

This function is used for three types of program: machining program, MDI program and fixed cycle program.

Press the main menu [Edit] key to display the program found when performing an operation search (MDI program in MDI mode).

Check display type	Enables to edit a program confirming the program check screen.
Multi-program display type	Enables to edit two programs using left and right editing areas.
G-code guidance display type	Enables to edit a program referring to the G code guidance.
Playback display type	Enables to edit program trying sample machining.

There are two types of editing available: regular editing and mass-editing. The specification and the limitation are different between regular editing and mass-editing.

The conditions and the maximum edit size of mass-editing are as follows.

Conditions of mass-editing	Maximum edit size
- Storage location of the opened machining program is memory card. - The size of the file is 0.5MB or more.	20MB

CAUTION

 **The program including a character of any language other than the display language is not correctly displayed. Do not edit such a program. Any part of the program other than the comment part may also be changed if edited.**

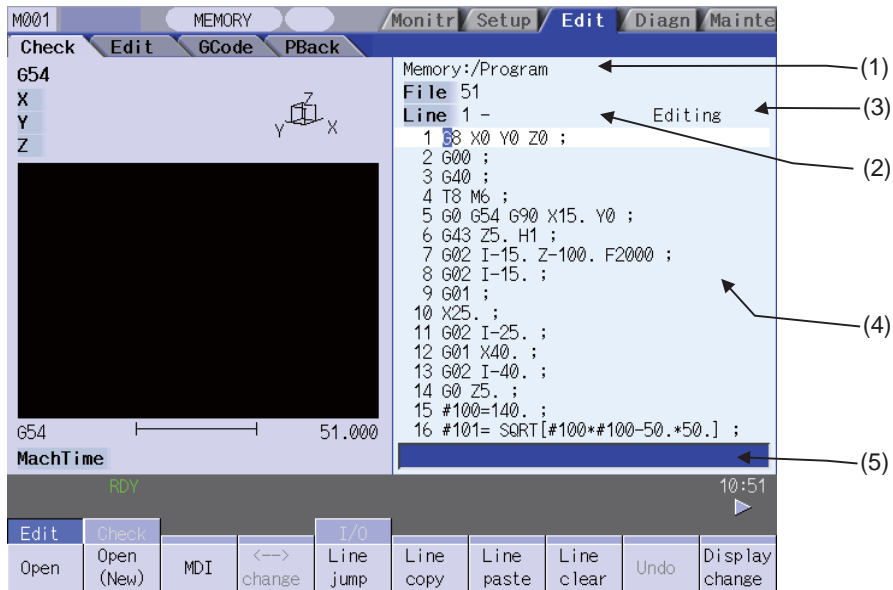

Display items

Display item	Details
(1) Path display	This displays the path for the open program file. (Ex.)Memory: /program When the path is too long, the characters exceeding the 37 characters (1-byte code) can not be displayed.
(2) Program name	[Program name (file)] This displays the file name of the program currently being edited. This displays "MDI" when the MDI program name is being edited.
Top display line	[Top display line] This displays the line number for the first. Proving an entire program is regarded as 100%, the position of the page currently displayed is shown in percentage during mass-editing.
(3) N No. additional value display	[N No. additional value display] This displays an automatic additional value of sequence No.
Edit type display	[Edit type display] This displays "EX" in mass-editing.
Current edit display "Editing"	[Current edit display "Editing"] This displays when performing edit operations after displaying the program.
Insert mode display "INS"	[Insert mode display "INS"] This displays when pressing the [INSERT] key and changing to the insert mode.
(4) Line number	[Line number] This displays the last 3 digits of the program line number. The line No. attaches only to the first line when over two or more lines are displayed on the screen because one line is long. The line No. does not attach during mass-editing.
Program display	[Program display] This displays the contents of the program (machining program, MDI program) currently being edited. The line with the cursor is emphasized. The line is not emphasized during mass-editing.
(5) Input area	This inputs the program line number and search character string.

Menus

Menu	Details	Type	Reference
Open	This edits and references the existing programs. When the program number is designated and the [INPUT] key is pressed, the program contents appear and can be edited.	A	4.2.2 Editing a Machining Program
Open (New)	This creates a new program. When the program number is set and the [INPUT] key is pressed, a new program is created.	A	4.2.1 Creating a New Machining Program
MDI	This edits the MDI program. When this menu key is pressed, the MDI program appears and can be edited.	A	4.2.3 Editing MDI Program
↔ change	This switches the active area between left and right editing areas. Editing can be done in the active area. This menu can be used with the multi-program display type.	C	4.2.7 Changing the Display
Line jump	With regular editing, when the line number is set and the [INPUT] key is pressed, the cursor moves to that line number.	A	4.2.8 Designating an Arbitrary Line
% jump	With mass-editing, proving an entire program is regarded as 100%, designate the position of the page to be displayed in percentage and press the [INPUT] key. The program data of the designated display position is displayed on the screen. The cursor jumps to the top line of the displayed program.		
Line copy	This copies the designated line (multiple lines can be copied.) This menu cannot be selected during mass-editing.	A	4.2.14 Copying/Pasting Data
Line paste	This inserts the copied line at the line before the cursor. This menu cannot be selected during mass-editing.	C	
Line clear	This erases the designated line (multiple lines can be erased.) This menu cannot be selected during mass-editing.	A	4.2.11 Deleting Data
Undo	In E70 series, this menu cannot be selected.		
Display change	This switches the display type.	C	
String search	When the character string is designated and the [INPUT] key is pressed, that character string is searched for. This menu cannot be selected during mass-editing.	A	4.2.12 Searching for Character Strings
String replace	If the character string to be searched for and the character string to be replaced are separated with a "/" and designated, when the [INPUT] key is pressed, the character string is replaced. This menu cannot be selected during mass-editing.	A	4.2.13 Replacing Character Strings
Miss warning	In E70 series, this menu cannot be selected.		
Next miss	In E70 series, this menu cannot be selected.		
N auto add	The sequence No. can be added automatically by pressing the [INPUT] key after designating an additional value. This menu cannot be selected during mass-editing.	A	4.2.15 Adding Sequence No. (N No.) Automatically
MDI regist	This registers the MDI program in the memory. This can be performed only when the MDI program is displayed.	A	4.2.3 Editing MDI Program
Erase file	This deletes the programs. When the name of the program to be erased is designated and the [INPUT] key is pressed, the designated file is deleted.	A	4.2.5 Deleting a File
Close	This closes the pop-up window and quits this function.	C	

4.2.1 Creating a New Machining Program

Operation method

- (1) Press the menu [Open (New)] .



The following menu appears.
The list appears as a pop-up window.

Memory			Memory card			USB Memory	Top jump	Bottom jump	Close
--------	--	--	-------------	--	--	------------	----------	-------------	-------

- (2) Select a device. (Ex.) Menu [Memory]



The selected device name and directory (Memory: /Program) appear in the Device name, Directory display column. For the devices other than memory, root directory is selected.

- (3) Input the file name for the program to be newly created and press the [INPUT] key.
(Ex.) 100 [INPUT]



If a program can be newly created, a program containing only EOR is created.
The list display is closed.

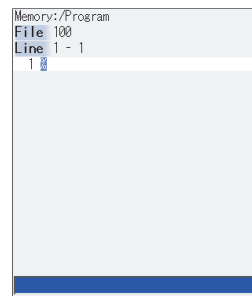

- (4) Edit a machining program.



Refer to "4.2.6 Edit Operations" and later.

- (5) Press the [INPUT] key.



The created machining program is saved to the device.

(Note 1) An error occurs if an existing program No. is set.

(Note 2) The texts in parentheses () at the top block of the program is the comment.

(Note 3) The existing file cannot be set.

(Note 4) The characters that can be used for the file name and directory path are 1-byte number, 1-byte capital alphabetical letters, and 1-byte symbols recognized by the system.

Note that the following characters cannot be used.

|, /, :, ", " (comma), *, ?, ", <, >, a to z (small letters), Space

In addition, the following cases cannot be treated as the file name.

- When the extension is such as "\$\$\$", "\$\$0", "\$\$1", "\$\$2", "\$\$3", "\$\$4", "\$\$5", "\$\$6", "\$\$7", "\$\$8", "\$\$9".
- When the file name is 1-byte character "0" (zero).

(Note 5) Creation of a program is not possible for a program with 33 or more file name characters.

(Note 6) When a parameter "#8936 Delete leading 0" is set to "1", if a file name consisting only of numerical figures is input, "0" at the head of the file name is deleted and then a file is newly created.

Refer to "When creating a new machining program" in "4.4.15 Leading Zero" for details.

4.2.2 Editing a Machining Program

Operation method

- (1) Press the [Open] menu.



The following menu appears. The list appears as a pop-up window.

Memory			Memory card			USB Memory	Top jump	Bottom jump	Close
--------	--	--	-------------	--	--	------------	----------	-------------	-------

- (2) Select a device.
(Ex.) Menu [Memory]



The selected device name and directory (memory: /program) appear in the Device name, Directory display column. For the devices other than memory, root directory is selected.

- (3) Use the [↑], [↓], [↑], [↓] keys to align the cursor with target machining program.
The name of the machining program to be edited can be input in the input area.

- (4) Press the [INPUT] key.



The program appears at the top if the file can be opened. The cursor moves to the head character of the program. The mode enters the overwrite mode. The list display is closed.

```
Memory:/Program
File 348
Line 1 - 16
1 G348(PARTS1) ;
2 G28 XYZ;
3 G92 G53 XYZ;
4 T3 ;
5 M6 T5 ;
6 N10 ;
7 G90 G0 X0 Y0 ;
8 Z5. ;
9 G643 H3 Z5. ;
10 M3 ;
11 F1000 S3000 ;
12 M3 ;
13 N20 ;
14 G41 D3 ;
15 G3 Z-20. I20. P3. ;
16 G1 X90. Y100. F1000 ;
```

- (5) Edit a machining program.



Refer to "4.2.6 Edit Operations" and later.

- (6) Press the [INPUT] key.



The edited machining program is saved to the device.

- (Note 1) An error occurs if a nonexistent program No. is set.
- (Note 2) If the selected program is running or program restarting, it can be displayed but not edited.
An error occurs when the data is set or the [INPUT] key is pressed.
- (Note 3) The fixed cycle program list displays when basic common parameter "#1166 fixpro" is set to "1".
- (Note 4) Editable size differs depending on each device. When the editable size is exceeded, the operation message "Can't edit because of size over" appears.
- (Note 5) "Loading" is displayed in flickering until the file is opened.
- (Note 6) Editing is not possible for a program with 33 or more file name characters.
- (Note 7) When the program in search was edited, the program is searched again as follows depending on the last operation.
- Search -> Edit: The position in which ONB is displayed is searched again.
 - Search -> Reset 1-> Edit: The program top is searched again.
 - Search -> Reset 2-> Edit: The search is not executed. If a program was added or deleted, the search position may shift.
 - Search -> Restart & Search -> Edit: The program top is searched again.
- (Note 8) If an attempt was made to open the currently edited file in the custom screen from this screen, the operation message "Read-only as the file is being edited" may appear.
- (Note 9) If an attempt was made to edit the currently edited file in the custom screen from this screen, the operation message "Read-only file - Can't edit" appears and may not be able to edit.
- (Note 10) Display will change as follows depending on the value set in the user parameter "#19006 EOR Disable".
- (1) When the user parameter "#19006 EOR Disable" is set to "0":
 - When a file including "%" is opened in the edit screen, characters up to "%" will be displayed. By saving the file, characters after "%" will be discarded.
 - When a file not including "%" is opened, "%" will be displayed at the end of the edit screen. By saving the file, "%" will also be saved.
 - When an external device file, other than NC memory, is opened, it will be displayed in the edit file with skipping the first line.
 - (2) When the user parameter "#19006 EOR Disable" is set to "1":
 - The contents of a file will be displayed in the edit screen as it is.
 - When a file whose last character is other than "%" is opened, "%" will be displayed at the end of the edit screen. "%" will be saved by saving the file. For example, if the end of the file is "%" + "CRLF", an extra "%" will be added at the end.
 - When an external device file, other than NC memory, is opened, the first line will not be skipped.
 - "Line copy" and "Line clear" can be made at the lines other than the last line which includes "%".

4.2.3 Editing MDI Program

Operation method

- (1) Press the menu [MDI] .



The menu is highlighted. The MDI program is displayed from the head of the active editing area. The cursor moves to the head character of the program. The mode enters the overwrite mode.

```
Memory://Program
File MDI
Line 1 - 4
1 G28 XYZ;
2 G32 G53 XYZ;
3 G40 G49 G80 G89 ;
4 %
```

- (2) Edit the MDI program.



Refer to "4.2.6 Edit Operations" and later.

(Note 1) Before starting MDI operation, confirm that the MDI settings are completed. If "Editing" or "MDI no setting" is displayed, the MDI operation cannot be started.

When the [INPUT] key is pressed, the head block will be searched, and the message "MDI search complete" will appear. The setting will then be completed.

If the cursor is moved without editing, the block indicated by the cursor will be searched for when the [INPUT] key is pressed.

(Note 2) If the [INPUT] key is pressed when the number of MDI program characters including EOB (;) and EOR (%) exceeds 2000, "Memory capacity over" message will appear and the MDI program will not be searched for execution.

Note that the contents edited after the MDI program is saved last will not be saved in the NC memory.

(Note 3) When "#1288 ext24/bit0 (MDI program clear)" is set to "1", the MDI programs are cleared at the following operations, and only % programs are saved.

- When MDI operation ends
- When the power is turned ON again
- When reset is input
- When emergency stop is canceled

Regardless of the operation mode, the MDI programs are cleared.

If the above operations take place during editing the MDI programs, the MDI programs before editing will be cleared.

Even if the [Undo] menu is pressed after clearing MDI programs, the programs before clearing will not return.

4.2.4 Registering MDI Program in NC Memory

Operation method

- | | | | |
|-----|---|---|--|
| (1) | Press the menu [MDI regist] . | ➔ | The menu is highlighted and turned to the program No. input wait status.
The cursor appears in the input area. |
| (2) | Set the program No. to be registered and press the [INPUT] key. | ➔ | MDI program is registered in the memory. The operation message "MDI entry complete" is displayed.
The menu highlight returns to normal. The cursor returns to the program display area. |

- (Note 1) When the [INPUT] key is pressed without entering the program name, a setting error occurs.
- (Note 2) When the entered program name already exists in the NC memory, the operation message "Overwrite this file?(Y/N)" is displayed.
When a parameter "#8936 Delete leading 0" is set to "1", if a file name consisting only of numerical figures is input, "0" at the head of the file name is deleted.
- (Note 3) MDI programs cannot be registered in the NC memory in the following cases.
- When the setting is made for other than programs with the parameter "#1166 fixpro".
 - During "Editing" is displayed.
 - When the remaining size of program is smaller than the MDI program to be registered.
 - When the remaining number of programs that can be registered is "0".
 - Entered program name already exists in the NC memory, and the status is in automatic operation or program restarting.
 - When the program name to be input is subject to edit lock (edit lock B: 8000 to 9999, edit lock C: 9000 to 9999), the operation message "Edit lock B" or "Edit lock C" appears, and the program name cannot be registered.
- When "#8936 Delete leading 0" is set to "1", if a file name consisting only of numerical figures is input, "0" at the head of the file name is deleted to be checked.
(Ex. When MDI registration is designated to "008000" while edit lock B is valid, the operation message "Edit lock B" appears, and the program name cannot be registered.)
- (Note 4) When a parameter "#8936 Delete leading 0" is set to "1", if a file name consisting only of numerical figures is input, a file is newly created with the "0" at the head of the name deleted.
However, if the file name is out of the range between 1 and 99999999, the leading "0" is not deleted.
This also applies to MTB macros.
- (Note 5) If the file to be registered is being edited in the custom screen, the operation message "Read-only file - Can't edit" appears and may not be registered.



4.2.5 Erasing a File

Operation method

- (1) Press the menu [Erase file].  The following menu appears.
The list appears as a pop-up window.

Memory			Memory card			USB Memory	Top jump	Bottom jump	Close
--------	--	--	----------------	--	--	---------------	-------------	----------------	-------

- (2) Select a device.
(Ex.) Menu [Memory]  The selected device name and directory (memory: /program) appear in the Device name, Directory display column.
For the devices other than memory, root directory is selected.

- (3) Use the [↑], [↓], ,  keys to align the cursor with target machining program.
The name of the machining program to be deleted can be input in the input area.

- (4) Press the [INPUT] key.  The operation message "Erase? (Y/N)" appears.

- (5) Press the [Y] or [INPUT] key.  The file is erased. The list display is closed.
Press the [N] key not to delete.

(Note 1) The file is not erased in the following cases.

- The file that is to be erased is currently being used in automatic operation.
- The file that is to be erased is subject to edit lock B or C.
- Data protection key 3 is enabled.
- The file to be erased is in the "program restarting" state.

(Note 2) If the file to be erased is being edited in the custom screen, the operation message "Can't erase designated file" appears and it may not be deleted.

4.2.6 Editing Operations

When the program is edited, the key input data is directly written into the program display area. All data is overwritten from the cursor position. "Editing" appears on the right side of the file name display once input is started.
Press the [INPUT] key to save the program to the device and clear the "editing" message.

The editing operations from when the file is actually opened are explained in the following sections.
These editing operations are common for the machining program and MDI program.

CAUTION

 If "there is no value after the G" command, the operation will be the "G00" operation when the program is run due to key chattering, etc., during editing.

4.2.7 Changing the Display

Switching the active area

Switching the active area is possible only when the multi-program display type is selected. Press the [←→ change] key to switch the active area between the left and right window.

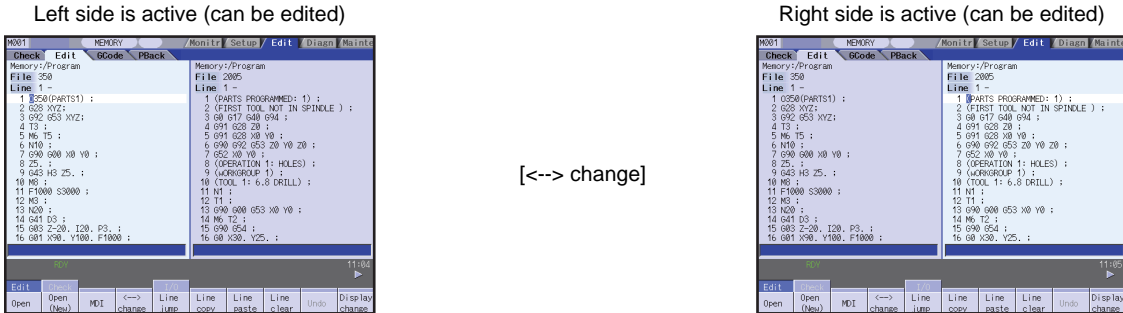

Changing the display using the page changeover keys (▲ : Previous Page, ▼ : Next Page)

- ▲ key: This displays one page of preceding lines of the current top line. When there is less than one page of data, a page of data will be displayed including the data currently displayed. (The cursor moves to the last line of the screen. Cursor does not move in mass-editing.)
- ▼ key: This displays one page of following lines of the current bottom line. (The cursor moves to the top line of the screen. Cursor does not move in mass-editing.)

Changing the display with the cursor key

The cursor will move up one line in the program each time the cursor key ([↑], [↓]) is pressed. If the [↓] key is pressed at the top line of the program display area, the program will scroll up one line. If the [↑] key is pressed at the end, the program will scroll down one line. When a block is displayed over 2 or more lines, [↑][↓] keys move the cursor by block unit during regular editing and by line unit during mass-editing.

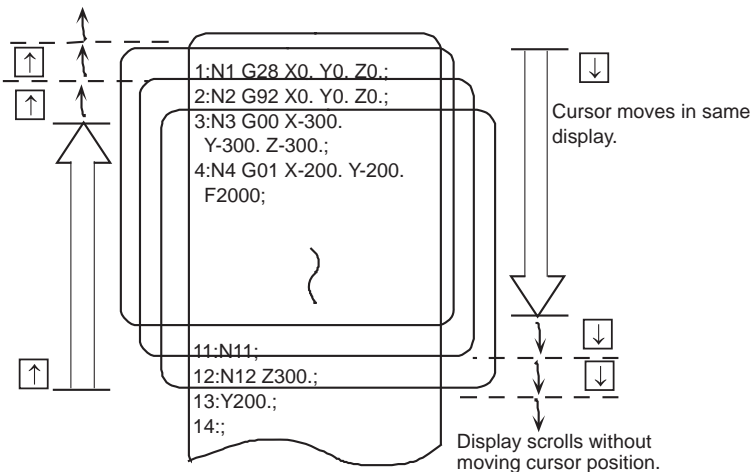

Move the cursor using the tab keys ([| ←] : back tab/ [→ |] : tab).

[| ←]key :Moves to the start of the word where the cursor is currently positioned.

If the cursor is at the start of a word, it moves to the start of the previous word.

[→ |]key :Moves to the word after the word where the cursor is currently positioned.

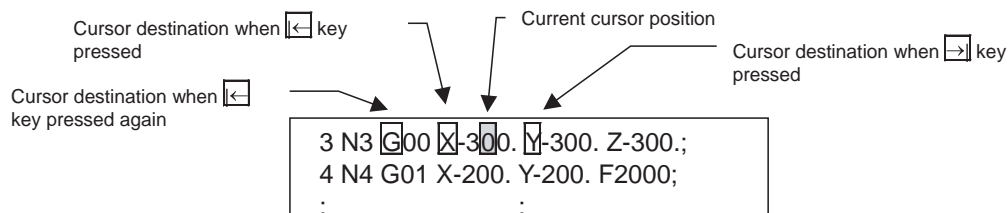

(Note) Pressing [| ←] [→ |] keys or [←] [→] keys does not make any difference in mass-editing.

Split display by word unit

In regular editing, program is split by word unit and displayed.

In mass-editing, program is not split by word unit and displayed as text data.

4.2.8 Displaying an Arbitrary Line**Operation method**

(1) Press the menu [Line jump] .



The menu is highlighted.
The cursor appears at the lower input area.

```
Memory:/Program
File 348
Line 1 - 16
1 G348(PARTS1) ;
2 G28 XYZ;
3 G82 G53 XYZ;
4 T3 ;
5 M6 T5 ;
6 N10 ;
7 G90 G0 X0 Y0 ;
8 Z5. ;
9 G643 H3 Z5. ;
10 M8 ;
11 F1000 S3000 ;
12 M3 ;
13 N20 ;
14 G41 D3 ;
15 G3 Z-20. I20. P3. ;
16 G1 X90. Y100. F1000 ;
```

(2) Input the line No.

(Ex.) 6 [INPUT]



The program appears with the set line No. at the head.
The cursor moves to the head.
The menu highlight returns to normal.



```
Memory:/Program
File 348
Line 6 - 21
6 N10 ;
7 G90 G0 X0 Y0 ;
8 Z5. ;
9 G643 H3 Z5. ;
10 M8 ;
11 F1000 S3000 ;
12 M3 ;
13 N20 ;
14 G41 D3 ;
15 G3 Z-20. I20. P3. ;
16 G1 X90. Y100. F1000 ;
17 G91 X100. ;
18 Y100 ;
19 X-100. ;
20 Y-110 ;
21 N30 ;
```

(Note 1) When "0" is input, the cursor moves to the first line.

(Note 2) When "E" is input, the cursor moves to the end.

4.2.9 Rewriting Data



Operation method



- (1) Move the cursor to the position of the data to be rewritten.
The cursor can be moved to one place to the right of EOB (;).
- (2) Set the data.  The message "Editing" appears when setting is started. The data is set from the position of the cursor. Data at the area is overwritten. The cursor moves one space (character) at a time to the right as the data is set.
- (3) When one line of setting is completed, press the [INPUT] key.  EOB (;) is added to the set data and the data is fixed. When newly creating data, the cursor moves to the head of the next line. When changing existing data, etc., the cursor does not move.

- (Note 1) Up to 255 characters can be input in one block in regular editing and 127 characters in mass-editing.
- (Note 2) When the cursor is on or one place to the right of EOB (;), input data is inserted even if not in input mode (refer to "4.2.10 Inserting Data".)
- (Note 3) When changing to another function such as the program check, or to another screen such as the operation screen when "Editing" displays, the operation message "Save current file? (Y/N)" displays. If [N] key is pressed changing to the other screen once, and the Edit screen is selected again, the program before editing operation will be displayed. (Edited contents will be invalid.)
- (Note 4) "Saving" is displayed in flickering during saving.

4.2.10 Inserting Data



Operation method

- (1) Move the cursor to the position where data is to be inserted.
- (2) Press the [INSERT] key.  The insertion mode is entered. "INS" and "Editing" appear to the right of the file name.
- (3) Set the data.  The data is inserted before the cursor position. Data after the cursor moves to the right.
- (4) When the setting is completed, press the [INPUT] key.  The set data is fixed. The cursor does not move, but if there is no EOB (;) at the end of the line, it will be added. Then, the cursor moves to the next line. The mode returns to the overwrite mode, and the message "Editing" disappears.



- (Note 1) Up to 256 characters can be set in one line.
- (Note 2) The insertion mode will be finished if a key such as [DELETE], [C.B], [CAN], [INPUT], [↑], [↓], [←], [→], [↵], [→|],  or  pressed.
- (Note 3) During regular editing, EOB (;) is added to the line without EOB (;) before moving to the next line; EOB (;) is not added to the the line with EOB (;). (No cursor movement.)
- (Note 4) During mass-editing, linefeed is inserted every time EOB (;) is input. (Cursor moves to the head of next line.)

4.2.11 Deleting Data

Operation method (Deleting one character)

- (1) Move the cursor to the character to be deleted.
- (2) Press the [DELETE] key.  1 character is deleted at the cursor position, and "Editing" appears. The data from the cursor position moves to the left. When this key is held down, the characters can be deleted one at a time.
- (3) Press the [INPUT] key.  The edited machining program is saved to the device and "Editing" disappears.

Operation method (Deleting one line)

- (1) Move the cursor to the line to be deleted.
- (2) Press the [C.B] key.  1 line is deleted at the cursor position, and "Editing" appears. The lines following the cursor position are shifted upward. The cursor position does not change. When this key is held down, the line can be deleted one at a time.
- (3) Press the [INPUT] key.  The edited machining program is saved to the device and "Editing" disappears.

(Note 1) In the case where the block for the deleted line covers multiple lines, these lines are also deleted.

(Note 2) Last line only with "%" cannot be deleted.

Operation method (Deleting designated lines)

(1) Press the [Line clear] menu.



The menu is highlighted.
The cursor appears at the lower input area.

(2) Designate the deletion range.
(Ex.) From line 8 to line 10
8/10 [INPUT]



The background color for the range to be deleted turns light blue. The operation message "Erase? (Y/N) " appears.

When deleting 1 line, it is also possible to make a selection using the [↑], [↓] keys and designate by pressing the [INPUT] key.

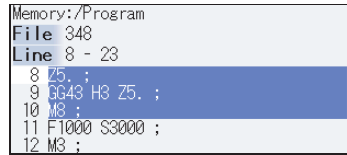

(3) Press the [Y] or [INPUT] key.



The data in the range with the blue background is deleted and the menu highlight returns to normal. The lines following the deleted data are shifted upward.
The cursor position and top line No. do not change.

Press the [N] key not to delete.

(Note 1) If the [INPUT] key is pressed without setting a line No., the line where the cursor is will be deleted.

(Note 2) If the last line of the file is the range to be deleted, the last line can be designated as "E".

(Example) From 8th line to last line : 8/E

From 1st line to last line: /E

(Note 3) "Executing" is displayed in flickering during line clear.

Operation method (Deleting several lines (one screen of data) displayed on a screen)

(1) Press the [SHIFT] and [C.B CAN] keys.



The block that is positioned at the top of the current display and its following 16 blocks are deleted.
If some of the blocks are longer than the field width and the last few blocks of the 16 blocks to be deleted are pushed outside of the visible area because of that, be noted that those blocks will still be deleted.

(2) Press the [INPUT] key.



The edited machining program is saved to the device and "Editing" disappears.

4.2.12 Searching for Character Strings



Operation method

- | | | |
|--|---|---|
| (1) Press the [String search] menu. | ➔ | The menu is highlighted
.The cursor appears at the lower input area. |
| (2) Set the character string to be searched for, and press the [INPUT] key.
(Ex.) G20 [INPUT] | ➔ | A search for a character string is made from the character after the cursor position downwards.If the character string is discovered, the cursor moves to the start of that character string.A message appears if there is no character string applicable to the program.Marking can be performed by adding an option to the character string being searched for.
(Ex.) G20/MR :G20 are marked in red.
(Refer to the "Marking function" for further details.) |
| (3) To continue searching, press the [INPUT] key again. | ➔ | The next corresponding character string is searched for.
The search finishes when the end of the program is reached.
(Note)It is not possible to return to the head of the program and resume the search. To search from the head of the program, move the cursor to the top line and carry out the search operation again. |
| (4) To end the search, press the menu key. | ➔ | The menu highlight returns to normal, and the character string in the input area disappears.
The search mode is held until the menu key is pressed.
(The character string remains in the input area.) |

(Note 1) "Executing" is displayed in flickering during string search.

Marking function

Marking can be performed by the character string being searched for.

Argument character string format	Details	Marking color
"Search character string"	The cursor moves to the character string searched for.	None
"Search character string/MR"	The cursor moves to the character string searched for. All displayed searched character strings are marked in red.	Red 
"Search character string/MB"	The cursor moves to the character string searched for. All displayed searched character strings are marked in blue.	Blue 
"Search character string/MG"	The cursor moves to the character string searched for. All displayed searched character string are marked in green.	Green 
"/MC"	The marking for all marked character strings is cleared.	-
"/MCR"	The marking for character strings marked in red is cleared.	-
"/MCB"	The marking for character strings marked in blue is cleared.	-
"/MCG"	The marking for character strings marked in green is cleared.	-

- (Note 1) The marking status is maintained when another program is opened while character strings are still marked.
- (Note 2) If the input mistake check warning function is enabled while character strings are still marked, the marking is given priority in the case where the input mistake location and the marked display overlap.
- (Note 3) In the case where the search marking and input mistake check warning function are displayed simultaneously, the marking is cleared and the input mistake warning display remains.
- (Note 4) With the multi-program display type, the search and marking is valid only in the area where the search and marking is carried out.
- (Note 5) The marked status is maintained until the NC power is turned OFF.
- (Note 6) Marking function is invalid in mass-editing.

Important points when performing search

- (1) If the designated character string cannot be found, the operation message "Designated character string not found" will be displayed.
- (2) A search is performed for a character string containing the designated character string, irrespective of the characters before and after. As a result, if "G2" is designated, G20 - G29 and G200 etc. will also be the subject of a search.

Character string data setting example

Designated character string	Search character string example
N10	Character strings that include "N10" such as "N10" and "N100".
N10 X100.	Character string "N10 X100".
X-012.34	Character string "X-012.34" (A search is not performed for "X-12.34".)

4.2.13 Replacing Character Strings

A character string in a program can be searched for and replaced.

The following two methods can be used.

- The applicable character string is searched for and replaced one by one. (To search for the next character string, press the [INPUT] key.)
- All applicable character strings in the program are replaced in a batch. (Designate "/G" when setting.)

Operation method

- | | | |
|---|---|--|
| (1) Press the menu [String replace] . | ➔ | The menu is highlighted.
The cursor appears at the lower input area. |
| (2) Designate the search character string and the replace character string. (Ex.) Search character string: G02 Replace character string: In the case of G03G02/G03 [INPUT] (Note 1) | ➔ | The character string is searched downward from the character after the current cursor position. If a character string is discovered, the cursor moves to the start of that character string, and the operation message "Replace? (Y/N)" appears. If any character string is not found in the program, the cursor does not move. |
| (3) Press the [Y] or [INPUT] key.

Press the [N] key not to replace. | ➔ | The character string is replaced, and a search is performed for the next applicable character string. (If a batch replacement is performed, a search is not made as the replace has been completed.)
The operation message "Designated character string not found" appears when the end of the program is reached. "Editing" appears if replace is performed. |
| (4) Press the [Y] or [INPUT] key again if continuing the search/replace. | ➔ | The same operation as above is performed. |
| (5) To end search/replace, press the [String replace] . | ➔ | The menu highlight returns to normal, and the character string in the input area disappears. The replacement mode is held until the menu key is pressed.
(The character string remains in the setting area.) |

(Note 1) When batch replacing for all the character strings in the program, add "/G" to the above setting.

Search character string/replace character string/G (Ex.) G02/G03/G

During batch replacement, after replacing all character strings to the end of the program, the process ends while showing the last character string replaced. Note that the replacement mode is held, and the character string remains in the input area.

(Note 2) If the program character strings from the current cursor position to the last line are to be replaced in a batch, add "/E" to the above setting.

Search character string/replace character string/E (Ex.) G02/G03/E

(Note 3) "Executing" is displayed in flickering during string replace.

4.2.14 Copying/Pasting Data

Operation method (Copying)

- (1) Press the [Line copy] menu. ➔ The menu is highlighted.
The cursor appears at the lower input area.
- (2) Designate the range to be copied.
(Ex.) From line 8 to line 10
8/10 [INPUT] ➔ The background color for the range to be copied turns light blue. The menu highlight returns to normal.

When copying 1 line, it is also possible to make a selection using the [↑] and [↓] keys and designate by pressing the [INPUT] key.

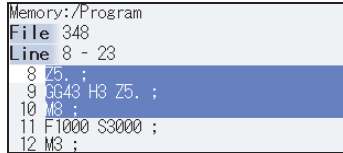

Notes when copying

- (1) If [INPUT] key is input without setting a line No., the line where the cursor is at is copied.
- (2) The highlight of the copy target lines disappears when editing operations are resumed.
- (3) If the file is edited after the Line copy menu is pressed, the data copied in the line is canceled.
- (4) If the last line of the file is the range to be copied, the last line can be designated as "E".
(Example) From 8th line to last line : 8/E
- (5) The copied data is maintained while the copy source file is opened even if the display type or editing area is switched to another one.

Operation method (Pasting the copied data)

- (1) Move the cursor to the line where the data is to be pasted.
- (2) Press the [Line paste] menu. ➔ The copied data is inserted in the line before the cursor position, and "Editing" appears.
- (3) Press the [INPUT] key. ➔ The edited machining program is saved to device, and "Editing" disappears.

(Note 1) With multi-program display type, data can be copied and pasted between both left and right areas.

(Note 2) "Executing" is displayed in flickering during line paste.

4.2.15 Adding Sequence No. (N No.) Automatically

When the sequence No. (N No.) is input once, the sequence No. to which a constant value is added can be automatically added to each block of the machining program.

The added sequence No. data is to N2 to N999999.

This function is disabled during mass-editing.

Operation method

(1) Press the menu [N auto add]. → The menu key is highlighted and turned to the additional value input wait status. The cursor appears in the input area.

(2) Input the additional value.
(Ex.) 10 [INPUT] → "N+10" is displayed in N No. additional value display column. The cursor moves from the input area to the edit area.

<When creating a new program>

(3) Press the menu [Open (New)], then press the menu [Memory]. → The list appears as a pop-up window. The machining programs in memory are displayed.

(4) Input a file name not used, then press the [INPUT] key.
(Ex.) 101 → "O101" is created in edit area.

(5) Input a program with N No.
(Ex.) N100G28XYZ



```
Memory:/Program
File 101
Line 1 -      N+10  Editing
1 N100G28XYZ
```

<When editing an existing program>

(3) Press the menu [Open], then press the menu [Memory]. → The list appears as a pop-up window. The machining programs in memory are displayed.

(4) Select a file, then press the [INPUT] key. → The selected file is opened in edit area.

(5) Move the cursor to the position where data is to be inserted. Press the [INSERT] key.

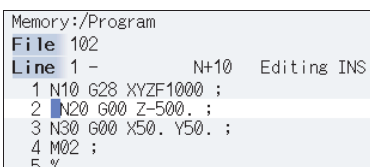

```
Memory:/Program
File 102
Line 1 -      N+10  Editing INS
1 N10 G28 XYZF1000 ;
2 N20 G00 Z-500. ;
3 N30 G00 X50. Y50. ;
4 M02 ;
5 %
```

(6) Input " ; " (EOB). → "N110" (previous block N No. "N100" + an additional value "10") is added after a " ; " (EOB).

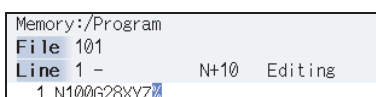

```
Memory:/Program
File 101
Line 1 -      N+10  Editing
1 N100G28XYZ
```

- (7) Input the second block data and ";" (EOB).
(Ex.) G92X0.Y0.Z0.;



"N120" is added behind ";".

```
Memory:/Program
File 101
Line 1 - N+10 Editing
1 N100G28XYZ;N110G92X0.Y0.Z0.;N120
```

- (8) Press the [INPUT] key.



The message "Editing" disappears. The program is saved.

```
Memory:/Program
File 101
Line 1 - N+10
1 N100 G28 XYZ;
2 N110 G92 X0. Y0. Z0. ;
3 N120 ;
4
```

The N No. data is automatically generated until the edit is interrupted with the [INPUT] key.

- (Note 1) When the menu [N auto add] is pressed again while the menu is highlighting, N No. additional value display column is cleared, and N No. automatic addition is canceled.
- (Note 2) The setting range is 1 to 1000. When "01" is input, "1" is set. When "0" is input, this function is canceled. When an illegal value or 9 characters or more is input, an error will occur.
- (Note 3) The additional value can be set even when the machining program has been not opened. Even if the machining program is opened again, the additional value is not invalid.
- (Note 4) This function is enabled only during regular editing of edit screen.
- (Note 5) This function is disabled during mass-editing. However, the set N No. additional value in regular editing is not cleared, and the additional value is valid during regular editing again.
- (Note 6) Even if the same N No. exists by automatic addition, an error will not occur.
- (Note 7) The system separately has N No. in a right area and left area of the edit screen.
- (Note 8) When the previous block is leading zero like "N010", N No. automatic addition can be executed. However, "0" is not added, and "N10" is displayed.

Example when N No. is added

- (1) When the previous block has N No. (When the cursor is located at the last character in the overwrite mode.)

```
N100 G28 X0 Y0 Z0 ; -> Input ";" -> N100 G28 X0 Y0 Z0;N110
N100 G28 X0 Y0 Z0 ; -> Input ";" -> N100 G28 X0 Y0 Z0 ;N110
N100 G28 X0 Y0 Z0 ; -> Input ";" -> N100 G28 X0 Y0 Z0 ;N110
```

- (2) When the previous block has N No. (When the insertion mode)

```
N100 G28 X0 Y0 Z0 ; -> Input ";" -> N100 G2;N110 X0 Y0 Z0 ;
N100G28X0Y0Z0; N200G90X20.Y20.Z20.;
-> Input ";" -> N100G28X0Y0Z0;N110 N200G90X20.Y20.Z20.;
```

Example when N No. is not added

- (1) When the previous block has no N No.

G00X10.% -> Input ";" -> G00X10.;%

- (2) When the head of previous block has no N No.

- Usually

G00N100X10.% -> Input ";" -> G00N100X10.;%

- When comment

(N100)G00N100X10.% -> Input ";" -> (N100)G00N100X10.;%

- When the previous block has a space

N100G00N100X10.% -> Input ";" -> N100G00N100X10.;%

- (3) When the N No. of previous block is over 9 characters.

N000001000.% -> Input ";" -> N000001000.%;

- (4) When limits of total characters display per block is exceeded.

- (5) When the N No. is over 1000000.

- (6) When the N No. automatic additional value is not set.

- (7) When the display character string in overwrite mode is interrupted.

N100 G28 X0;Y0 Z0 ; -> Input ";" -> N100 G28 X0;Y0 Z0 ;

4.2.16 G Code Guidance

G code guidance is a function that shows the command format details or the outline of its operation for the G code being edited while creating or editing the machining program. With this function, the G code format can be confirmed immediately. G code guidance is also displayed in the same manner even when MDI program is displayed.

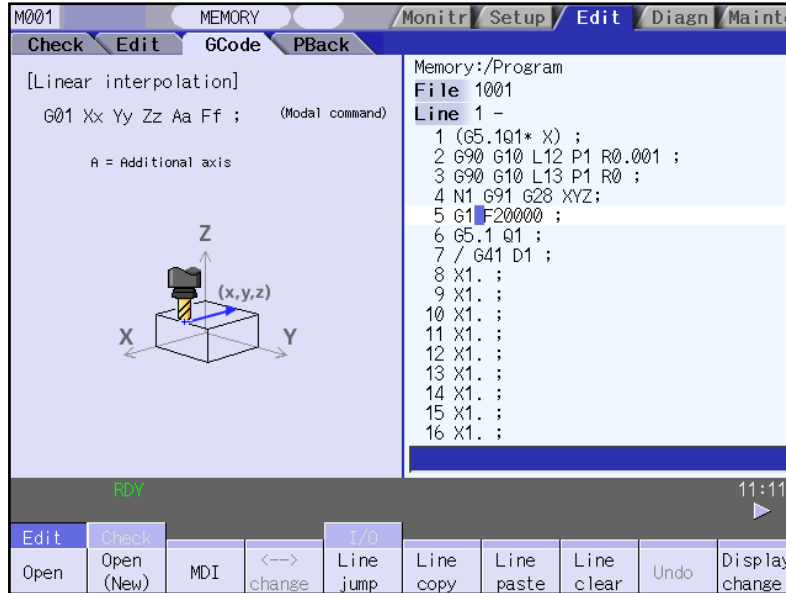

The contents displayed on the G code guidance area depends on the cursor position on the Edit screen, and is refreshed when moving the cursor.

The G code that meets following conditions are displayed in this area.

- G code that exists between the head of block and cursor position including the cursor position.
- G code that exists immediately before the cursor if multiple G codes meet the above condition.

Specific example

- G91 G17 ; █ ➡ The guidance will not be refreshed because the cursor is out of the block.
- G91 G17 █ ; ➡ The guidance for G17 will be displayed.
- G91 █ G17 ; ➡ The guidance for G91 will be displayed.
- G91 G00 X100. █ Y100. ; ➡ The guidance for G00 will be displayed because G00 is the nearest G code to the cursor.

G codes displayed in the G code guidance area

With G code guidance function, the commands having "G" followed by 1 or more numbers are regarded as the G code. Thus, when "G" that is located immediately before the cursor is within the comment, the guidance will not be refreshed. In the same manner, when a G code is commanded using variables such as "G#100" or "G#500", etc. but numbers, the guidance will not be refreshed.

The G code that can be displayed in the guidance area is as follows.

Gnnnnnnn.m L ll ("n", "m", and "l" are arbitrary number.)

Commanded value	Number of valid digits	Remarks
N(integer)	1 to 8	When including "0" before integer command value, unnecessary "0" is ignored.
m (decimal places)	0, 1	
l(value commanded using "L")	0 to 2	This is valid when "L" exists immediately after the integer command value or decimal command value and is followed by a command value. If the command with "L" address precedes G code, the "L" command will not be described in the guidance.

(Note 1) As for the G codes not included in the specifications, the guidance will not be displayed even if the above condition is met.

- | | | |
|-----------------------|---|---|
| G00 X100. (GCODE) ; | ➔ | "G" included in the comment "GCODE" is ignored, thus, G code guidance will not be refreshed. |
| N11 GOTO1 ; | ➔ | "G" included in the command "GOTO" is ignored, thus, G code guidance will not be refreshed. |
| G91 G120 X100 Y100. ; | ➔ | G code "G120" is not included in the specifications, thus, G code guidance will not be refreshed. |
| G00000031.1 | ➔ | The guidance for G31.1 will be displayed. |
| G00000031.10 | ➔ | Commanded value exceeds the number of valid digits, thus, G code guidance will not be refreshed. |
| L50 G10 | ➔ | The guidance not for "G10 L50" but "G10" will be displayed. |

Precautions for G code guidance

(1) G code guidance may be refreshed when the cursor is located near the comment.

[Ex.] (PROG01) ;  The guidance for G01 will be displayed.

(2) When the cursor is located at the axis address, etc., the guidance for the nearest G code will be displayed even if the address has no relationship with the G code.

[Ex.] G01 G90 X100 ;  G code that has a relationship with "X100. " is "G01", however, G code guidance for "G90" will be displayed.

(3) When moving the cursor to the block with no G code as follows, the contents of guidance will differ depending on the cursor's route even if the cursor is in the same block.

```

N01 G91 G01 X100. F1000
↓
[Ex.] N02 Y100. Z100. ; ← ... a
      ↑ b
N03 G02 X50. Y50. R50. ;
    
```

 When the cursor is moved by the route "a", the guidance for G01 which is displayed last in N01 block will also be displayed in N02 block. When the cursor is moved by the route "b", the guidance for G02 which is displayed last in N03 block will also be displayed in N02 block.

(4) The instructions of G-code guidance are commonly used for M700V, M70V, and E70 series. Thus, G code could not function though the guidance is displayed.

(5) Basically, G code format in the guidance is displayed using the format of 3-axis specifications of X, Y, and Z.

(6) Whichever plane is selected among the plane selection functions G17 to G19, the display data in the guidance is displayed using X-Y plane (G17) format.

(7) When the G code command includes an address which have two or more meanings, both contents will be displayed.

(8) G code guidance will not be refreshed while the character string is searched or replaced.

(9) G code guidance cannot be displayed in mass-editing.

(10) E70 loads guidance data from memory card (CF card) when NC starts, but if the memory card (CF card) is inserted after the NC has started, NC will load guidance data at the timing as follows.

- (a) When operation, parameter, or alarm guidance is displayed.
- (b) When switching display type to display G code guidance on edit screen.
- (c) When G code guidance is displayed during display transition.

When NC is loading guidance data, "guidance data loading" message will show up, and loading will take few seconds to complete.

(11) Once guidance data is loaded, guidance can be shown even after the memory card (CF card) is removed.

4.2.17 Playback Editing (M system)

The playback function enables creation of a program while trying sample machining by manual (handle or jog) feed or mechanical handle feed. A machining program can be created with movement distance data obtained by manual operation used as programmed command values.

	#1126 PB_G90	Reference
M system	0 (Incremental value)	Absolute/incremental command
	1 (Absolute value)	depending on G command

<Absolute/incremental command depending on G command>

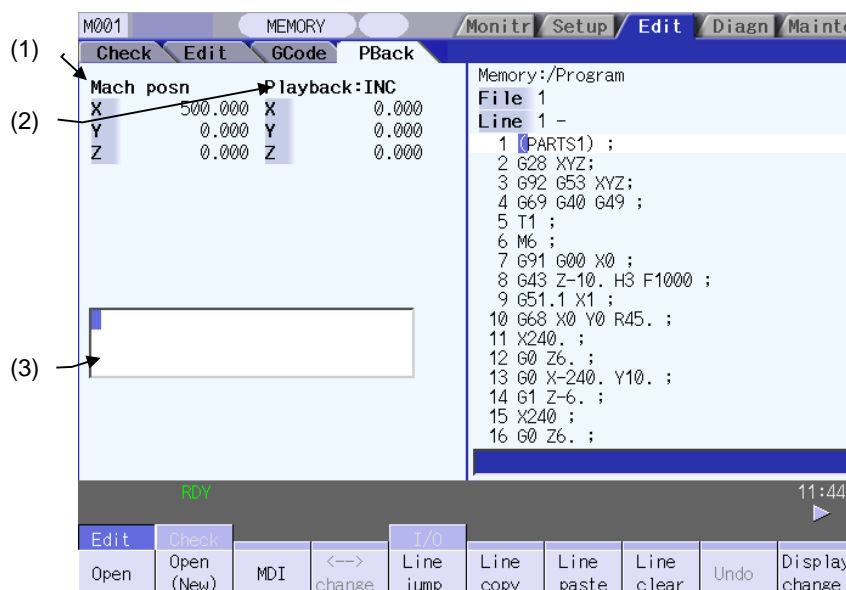

Display items

Display item	Details
(1) Machine position counter	This displays the machine position counter. M system: Max. 3 axes When the rotary axis (except for all coordinate linear type), the display range is 0.000° to 359.999° .
(2) Playback counter	This displays the playback movement amount (axis movement value).When "absolute/incremental command depending on G command", the title and playback movement amount differs according to the parameter "#1126 PB_G90".(Note 1) When "Absolute/incremental command depending on address code", both titles are displayed. M system: Max. 3 axes When the rotary axis (except for all coordinate linear type), the display range is following below. For INC (Rotary type short-cut disabled, workpiece coordinate linear type): -359.999° to 359.999° For INC (Rotary type short-cut enabled): -180.000° to 179.999° For ABS: 0.000° to 359.999°
(3) Playback editing area	The contents of playback editing is input. When the axis address keys such as X and Y are input, the playback counter value currently displayed is input after the axis address.

(Note 1) The displayed title and playback movement amount are as follows.

#1126 PB_G90	Title	Playback movement amount
0 (Incremental value)	Playback: INC	Playback movement amount before axis moves + axis movement amount
1 (Absolute value)	Playback: ABS	The program position + manual interrupt amount

Operation method (Absolute/incremental command depending on G command)

(1) Set "#1126 PB_G90" to "0" on the parameter screen. ➔ Incremental value mode is set.

(2) Press the [Display change] key several times on the edit screen. ➔ The "playback display type" is displayed. The menu [←→ change] cannot be used.

Mach	posn		P layback:INC
X1	150.000	X1	0.000
Y1	150.000	Y1	0.000
Z1	150.000	Z1	0.000

When the incremental value is set, the initial value is "0".

(3) Open the program pressing [Edit] and [Open] on the edit screen. ➔ The selected program is displayed in right area.

Mach	posn		P layback:INC
X1	150.000	X1	0.000
Y1	150.000	Y1	0.000
Z1	150.000	Z1	0.000

Memory:/Program
File 103
Line 1 -
1 M00(LOR CHK 01) ;
2 G28 XYZ ;
3 G90 G00 X500. Y0. F2000 ;
4 G01 X500. Y500. ;
5 G01 X0. Y500. ;
6 G01 X0. Y0. ;
7 G02 X250. Y0. R125. ;
8 G03 X500. Y0. R125. ;
9 M02 ;
10 %

(Note 1) When the program is not displayed in the right area, a playback editing will not be executed.

(Note 2) When the incremental value is set, playback movement amount will be cleared to 0 for all axes.

(4) Move the axis during manual mode. ➔ The axis movement amount is displayed in playback movement amount.

Mach	posn		P layback:INC
X1	100.000	X1	-50.000
Y1	190.000	Y1	40.000
Z1	180.000	Z1	30.000

In the incremental value mode, the axis movement amount by manual mode is added to currently playback movement amount.

When the absolute value is set, "the program position + manual interrupt amount" is displayed as the playback movement amount.

- (5) Input the data such as the G codes in the area for playback editing.



The alphanumeric characters, [←],[→] and [DELETE] keys can be input in the area for playback editing.

Mach	posn	Playback:INC
X1	100.000	X1 -50.000
Y1	190.000	Y1 40.000
Z1	180.000	Z1 30.000

F3000G01		
----------	--	--

(Note 1) If the [C/B] key is pressed, all the data in the playback editing area will be deleted.

(Note 2) When the [↑] and [↓] keys are pressed, the program cursor in the right area will move.

(Note 3) When the page-switching key is pressed, the program in the right area will scroll.

(Note 4) When the menu key is pressed, the process corresponding to the right area will run. When the cursor appears on input area of the right area by pressing [Line jump], [Line copy], [Line clear], [String search], [String replace], [MDI registration] or [N auto add], the key input is made to the input area of the right area. When window is displayed by pressing [Open], [Open(New)] or [Erase file], the key input is made to the currently displayed window.

(Note 5) The program cursor in the right area cannot move left and right, but can move only up and down.

- (6) Press the axis address key such as [X] or [Y].



The playback movement amount is input after the axis address in the playback editing area. If the axis address key is pressed while the playback movement amount is being changed, the playback movement amount at the time the key was pressed will be input.

Mach	posn	Playback:INC
X1	100.000	X1 -50.000
Y1	190.000	Y1 40.000
Z1	180.000	Z1 30.000

F3000G01X-50.		
---------------	--	--

(Note) When inputting a comment, etc., the characters that are the same as the axis address will all be handled as the axis address.

- (7) Press the [INPUT] key.



The program in the playback editing area will be inserted at the block before the cursor position in the right area, and the program is saved.

When there is no "EOB" (;) at the end of the character string, it is added automatically.

The cursor moves to the line head being cleared the content of the playback edit.

For an absolute value, the playback movement amount will not change. For an incremental value, the difference of the axis command value for the axis used in step (6) and the playback movement amount will remain as the playback movement amount.

(Note) If the program is not displayed on right area, the operation message "Can't execute playback edit" appears.

Notes for playback editing

- (1) Playback editing of a program in automatic operation or program restart is not possible.
- (2) Up to 95 characters can be edited in the playback editing area.
- (3) If the screen system is changed or the program file is opened when the input program is in the playback edit area, the program being edited will be aborted.
- (4) Other files can be opened during playback editing. Playback editing can be continued even when other file is opened. However, if an incremental value is designated, the playback movement amount will be cleared to 0 for all axes. A new file can be created and edited, and MDI editing carried out in the same manner.
- (5) If the program being playback edited automatically starts, playback editing cannot be continued.
- (6) The playback movement amount after playback editing will differ according to the parameter "#1126 PB_G90" state and the commanded G code. The playback movement amount after [INPUT] is pressed is calculated for each block that has been playback edited.

X axis playback movement amount before editing	Details to be playback edited	X axis playback movement amount after [INPUT]	
		For an absolute value	For an incremental value
X 100.000	G01 X10.;	X 100.000 The program position + manual interrupt amount is inserted as the playback movement amount.	X 90.000 The difference of the axis command value (X10.) and playback movement amount before [INPUT] (X100.) is inserted as the playback movement amount.
	G92 X10.;	X 10.000 The command value (X10.) following G92 is inserted as the playback movement amount.	X 0.000 Regardless of the command value following G92, 0 is inserted as the playback movement amount.

- (7) The playback editing is disabled during mass-editing.
- (8) If the file to be played back edit is being edited in the custom screen, the operation message "Can't write into being edited file" appears and may not be able to edit.
- (9) Do not set the same address to the parameter "#1013 axname" and "#1014 incax". If the same address is set, the absolute counter has priority.
- (10) The playback editing cannot be enabled for an axis of auxiliary axis state. When an axis address of auxiliary axis state is input, a setting error will occur.

4.3 Program Check (2D)



The program check function (2D) is used to graphically draw the machining program movement path without performing auto operation.

The machining program can be checked with graphic data drawn at a high speed.

Using [All display] menu, normal display and full-screen display modes can be switched.

■ Normal display ([All display] is OFF)

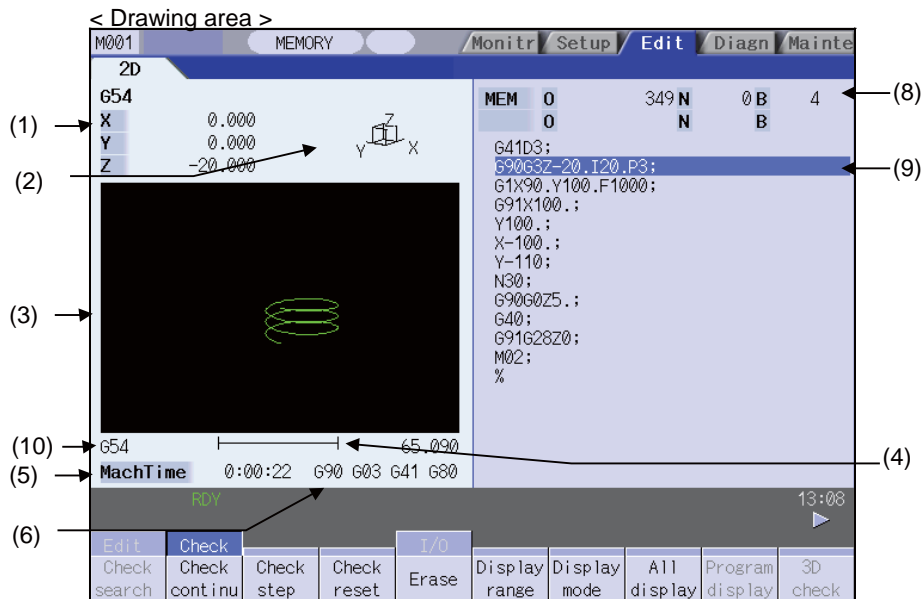

< Drawing area: 2-plane >

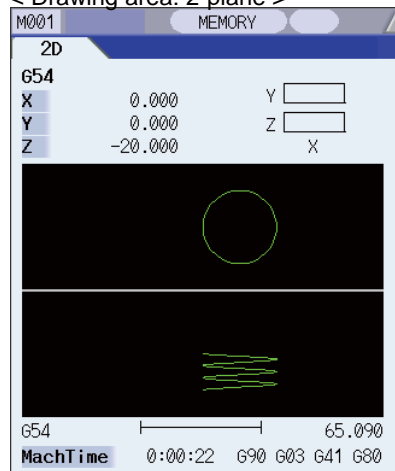

< Input area displayed >

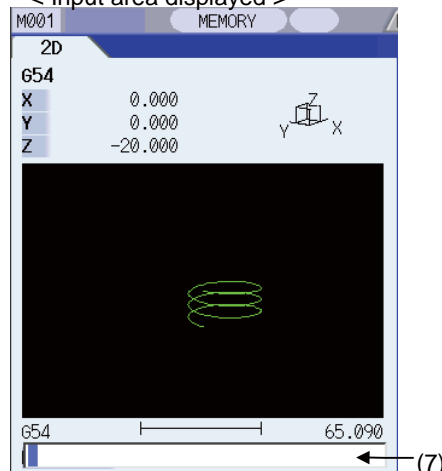

- Full-screen display ([All display] is ON)
< Drawing area >

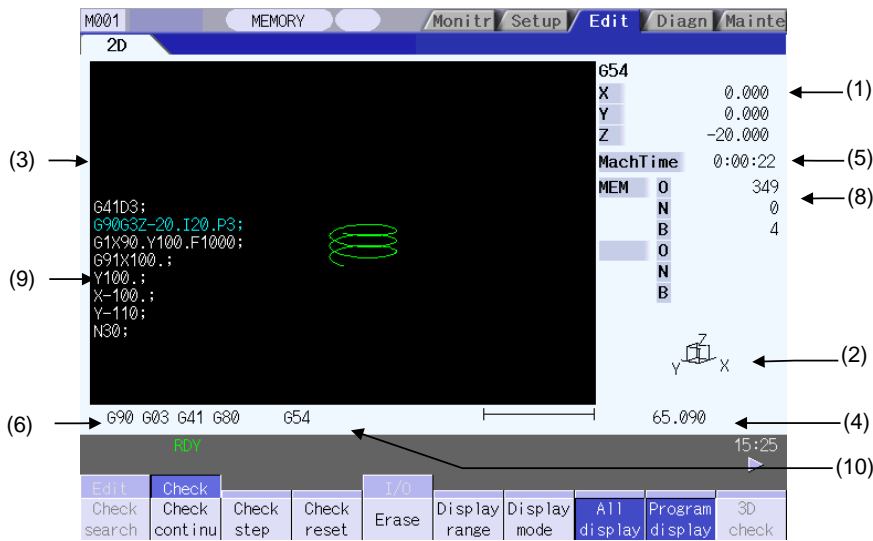

Display items

Display item	Details
(1) Check counter	<p>This displays the axis counter for the check drawing. Select the coordinate system to be displayed on the counter from the menu [Drawing System].</p> <p>When [All Wk. Coord] is selected: The display will be switched by the setting of "#1231 set03/bit1" and "#1231 set03/bit5". (Refer to "4.3.14 Switching the Draw Path".)</p> <p>When other than [All Wk. Coord] is selected: Regardless of the setting of "#1231 set03/bit5", the displayed counter will be of the workpiece coordinate position or the tool position (workpiece coordinate system).</p> <p>The 2nd axis name (#1022 axname2) which conforms to the basic axis name set in the user parameter "#1026 base_I", "#1-027 base_J", and "#1028 base_K" will be displayed for the 3 axes to display.</p>
(2) Display mode	This shows the plane for drawing.
(3) 2D drawing area	<p>This is the area where the tool path is drawn when performing a program check. The drawing viewpoint can be moved, and the drawing size can be enlarged and reduced. Select the coordinate system to draw from the menu [Drawing System].</p> <p>The display for the path to be drawn will be switched by the setting of "#1231 set03/bit1" and "#1231 set03/bit2". (Refer to "4.3.14 Switching the Draw Path")</p> <p>Select the zero point to be displayed with following parameter: #1231 set03/bit4 0:Basic machine coordinate system zero point 1:Workpiece coordinate system zero point</p>
(4) Scale	This shows the display range scale. Use [Zoom in] or [Zoom out] menu to change the scale value.
(5) Machining time display	This calculates and displays the machining time.
(6) G modal display for check	<p>This displays the following modals.</p> <ul style="list-style-type: none"> - Absolute/incremental (G90, G91: Group 3) - Operation mode (G00, G01, G02, G03 etc.: Group 1) - Tool radius compensation (G40, G41, G42: Group 7) - Fixed cycle (G80, G81 etc.: Group 9)
(7) Input area	<p>This displays details of the key input when setting the display axis name, and when setting the extended workpiece coordinate system as the coordinate to draw.</p> <p>Press the menu [Display mode] keys to display the input area.</p> <p>With the menu [Drawing system], the input area is displayed in the disabled state. With the menu [Coord G54.1P], the input area is enabled. With the [INPUT] key, the input area is hidden.</p>

Display item		Details
Currently executed machining program		
(8)	Main O10···	This displays the device name, program number, sequence number, and block number currently being executed.
	Sub O1234···	This displays the sub-program device name, program number, sequence number, and block number for the sub-program currently being accessed.
(9)	Buffer display	This displays the contents of the machining program currently being checked. The block being executed is highlighted.
(10)	Drawing coordinate settings display	This displays the current selected drawing coordinate settings.

Menus

Menu	Details	Type	Reference
Check search	This performs a check search. Select a program to perform a check for from the program file list displayed in the pop-up window.	C	4.3.1 Checking Continuously
Check continu	This checks the program continuously.	B	
Check step	This checks the program per block.	B	
Check reset	This resets the program check.	C	4.3.3 Cancelling the Program Check
Erase	This erases the graphics displayed on the screen. Each time this menu is pressed, the graphic data is erased in the order of rapid traverse and cutting feed. When the graphic is drawn after setting "#1231 set03/bit2" to "1", pressing this button again will erase whichever a path of rapid traverse or cutting feed at once.	C	
Display range	This changes the graphic drawing display range. Press this menu to display the menu for changing the display mode. This changes the display range and erases the graphic data displayed on the screen.	C	4.3.6 Changing the Display Range
Display mode	This changes the drawing plane. Press this menu to display the menu for changing the display mode. There are 3 types of graphic drawing display mode: 1-plane, 2-plane, and 3-dimension. This changes the drawing plane and erases the graphic data displayed on the screen.	C	4.3.7 Changing the Display Mode
All display	This switches the normal display mode and the full-screen display mode.	B	4.3.10 Switching to Full-screen Display Mode
Program display	This displays the machining program being checked on the graphic drawing area. This menu can be selected only when the full-screen display mode is applied.	B	
3D check	In E70 series, this menu cannot be selected		
Opt Skip	In E70 series, this menu cannot be selected.		
Rotate	This sets the viewpoint angle for the 3-dimension display mode. This changes the viewpoint angle and erases the graphic data displayed on the screen. However, this menu cannot be used for other than the 3-dimension display mode.	C	4.3.8 Changing the Display Angle
Std range	The display range (scale and display position) is automatically set from the machine movable area. The machine movable area is set with the parameters "#2013 OT-" and "2014 OT+" (software limit). When the display range is changed, the graphic data displayed on the screen is erased.	C	

Menu	Details	Type	Reference
Drawing System	This sets the name and values of the counter to display in the graphic check, and the coordinate system to be drawn.	C	4.3.4 Setting the Coordinate System to Draw
Auto Graphic	After the scale is automatically adjusted so that the entire machining program can be displayed in the 90% of the drawing area, the graphic is drawn on the center of the drawing area. It is automatically adjusted in the following cases. - When the program is selected - When display size is switched (normal display <-> full display) - When the display range is changed When auto graphic is valid, the menu is highlighted.	B	4.3.11 Setting auto graphic
Grid display	Whether to display or not the grid line in the drawing area for the 1-plane display mode can be selected. When the grid display is valid, the menu is highlighted.	B	
Next Ax	In E70 series, this menu cannot be selected		

- (Note 1) The menu [Operate search] key cannot be selected while the check is performed or interrupted. Menu can be selected after [Check reset] is pressed.
- (Note 2) While a scale is automatically adjusted or a graphic is drawn, the menu [Check search], [Check continu], [Check step], [Display range], [Display mode], [Std range] or [Drawing System] cannot be selected.
- (Note 3) The menu [Auto Graphic] or [Grid display] cannot be selected for other than the 1-plane display mode

4.3.1 Checking Continuously

Operation method

- (1) Press the main menu [Check] .  The program check screen becomes active.
- (2) Press the [Check search] key.  The following menu appears.
The list appears in a pop-up window.

Memory			Memory card				Top jump	Bottom jump	Close
--------	--	--	-------------	--	--	--	----------	-------------	-------

- (3) Select a device.(Ex.) Menu [Memory]  The selected device name and directory (memory: /program) appear in the device name and directory display columns.
- (4) Use the [↑], [↓], [↑] or [↓] key to align the cursor with the target machining program.
The name of the machining program to be edited can be input in the input area.
(Note) When the number of characters of directory path (full path) exceeds 48, changing directories cannot be performed.

- (5) Press the [INPUT] key.  The check search is started. The operation message "Search complete" appears when the search is completed.After performing the search, the device and program position appear in the current machining program display column.The list is then closed.The system distinguishes between the presence or lack of an extension, and therefore due care should be taken.
- When setting data exists in the input area, a search is performed in this data. This procedure is also used when performing an NB search.

(Ex.)
 1001/1/2 O1001 N1 B2
 1001.PRG/1/2 O1001.PRG N1 B2
 /1/2 (current O number) N1 B2
 1001//2 O1001 N0 B2
 1001/1 O1001 N1 B0
 1001 O1001 N0 B0
 /1 (current O number) N1 B0
 //2 (current O number) N0 B2

MEM	0	348	N	0	B	0
	0		N	0	B	0
0348(PARTS1);						
G28XYZ;						
G92G53XYZ;						
T3;						
M6T5;						
N10;						
G90G0X0Y0;						
Z5.;						
GG43H3Z5.;						
M8;						
F1000S3000;						
M3;						

- (6) Press the [Check continu] key.



A program check is executed and that path is drawn. A "Checking" message appears and the menu is highlighted. The check counter display is updated. The check G modal does not display. The machining time is updated.

A block stoppage occurs when performing a program check if the [Check continu] or [Check step] keys are pressed while performing a continuous check. Furthermore, the program check is restarted if the [Check continu] key is pressed during the block stoppage. The program check is reset if the [Check reset] key is pressed while performing a continuous check.

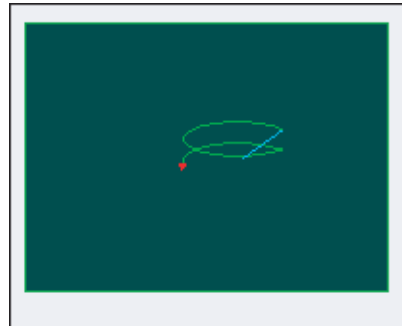

A "Program check completed" message appears when the continuous check is completed. The [Check continu] menu highlight returns to normal.

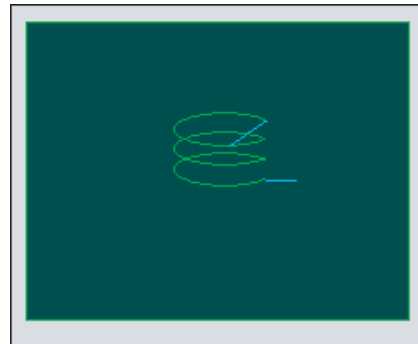

4.3.2 Checking One Block at a Time

Operation method

- (1) Press the main menu [Check] .
- (2) A check search is performed using the same method as for "4.3.1 Checking Continuously".
- (3) Press the menu [Check step] .



The program check screen becomes active.



The program check is executed for one block, and a graphic drawing of the machining program movement path is made. The check counter display is updated. The check G modal display is updated. The machining time is updated.
<State during one block check>

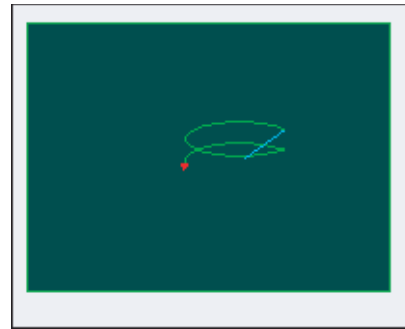

<State when one block check is completed>

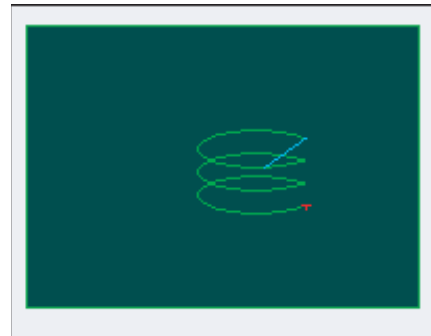

- (4) Press the menu [Check step] .



The program check is executed for the next block. The menu returns to normal state.

The program check is continued from the next block if the [Check continu] key is pressed during block stoppage.

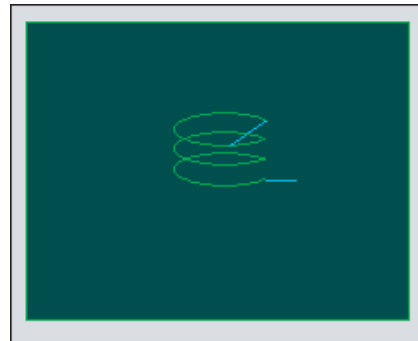

4.3.3 Canceling the Program Check

Operation method

(1) Press the menu [Check reset] .



The program check is reset and a "Reset complete" message appears.

4.3.4 Setting the coordinate system to draw

Press the menu [Drawing system] to select the coordinate system to draw from among the coordinate selection menus below. During the graphic check, it is possible to draw paths of the running programs of the selected coordinate system only.

If "All wk. coord" is selected, all paths of the program will be drawn. If other than "All wk. coord" is selected, paths of the program of only selected coordinate will be drawn. The default setting is "All wk. coord".

- (Note 1) The coordinate system to draw that is set here is held even after turning the power ON again.
- (Note 2) When the parameter "#1231 set03/bit4 (Switch zero point mark display position)" is set to "1", the zero point mark's position is not of the selected coordinate system to draw, but of the workpiece coordinate system or extended workpiece coordinate system specified by the machining program being checked.
- (Note 3) When the drawing coordinate system is set for other than "All Wk. Coord", if switching the coordinate system has not been commanded in the program to execute the program check, this draws the program performs drawing in the currently set coordinate system, that is not the correct position. Thus, note that the coordinate system is specified in the program.

Menus to select the coordinate system to draw

Menu	Details	Type	Reference
All wk. Coord	This draws all workpiece coordinate systems. The display for the check counter switches by the setting of "#1231 set03/bit1" and "#1231 st03/bit5". (Refer to "4.3.14 Switching the Draw Path".) In the area to show the setting of the coordinate system to draw, "All Work" is displayed.	C	Select the type of workpiece coordinate system to draw (When selecting all workpiece coordinates, or coordinate system G54-59)
G54	This specifies the workpiece coordinate (between G54 and G59) as a coordinate system to draw. In the graphic check counter, the workpiece coordinate position or tool position (workpiece coordinate system) counter is displayed regardless of the setting of the parameter "#1231 set03/bit5 (Switch graphic check counter display)". In the area to show the setting of the coordinate system to draw, the selected workpiece coordinate system is displayed.	C	
G55		C	
G56		C	
G57		C	
G58		C	
G59		C	
Coord G54.1 P	This specifies the extended workpiece coordinate (G54.1 Pn) as the coordinate system to draw. The graphic check counter is changed to the workpiece coordinate position or tool position (workpiece coordinate system) counter regardless of the setting of the parameter "#1231 set03/bit5 (Switch graphic check counter display)". In the area to show the setting of the coordinate system to draw, the selected workpiece coordinate system is displayed.	A	Select the type of workpiece coordinate system to draw (When selecting the coordinate system G54.1P)

Select the type of workpiece coordinate system to draw (When selecting all workpiece coordinates, or coordinate system G54-59)

- (1) Press the menu [All wk. coord].

In the area to show the setting of the coordinate system to draw, "All Work" is displayed.



In the same manner, by pressing a menu between [G54] and [G59], in the area to show the setting of the coordinate system to draw, the selected workpiece coordinate system is displayed.

Select the type of workpiece coordinate system to draw (When selecting the coordinate system G54.1P)

- (1) Press the menu [Coord G54.1P].



The operation message "Input P number" is displayed.
The menu is highlighted.
The input area is enabled.

- (2) Input "20", and press the [INPUT] key.



In the area to show the setting of the coordinate system to draw, "G54.1P20" is displayed.

Difference of drawing by combination of "CoordinateSystem" and "Coord Select"

By combination of the drawing coordinate system (CoordinateSystem) and the workpiece coordinate system selection (Coord Select), the drawing at 2D check changes as follows.

<Example>

[Workpiece coordinate]
 G54: X 100.000 Y 100.000 Z 0.000
 G55: X 200.000 Y 200.000 Z 0.000

[Machining program]
 N1 G28 XYZ
 N10 G90 G54 G0 X100. Y100. Z100.
 N11 G91 G01 X-100. F500
 N12 Y-100.
 N13 X100.
 N14 Y100.
 N15 Z-100.
 N16 Y-100.
 N17 Z100.
 N18 G0 Y100. Z-100.
 N19 G01 X-100. F500
 N20 Z100.
 N30 G28 XYZ
 N40 G90 G55 G0 X200. Y200. Z200.
 N41 G91 G01 X-100. F500
 N42 Y-100.
 N43 X100.
 N44 Y100.
 N45 Z-100.
 N46 Y-100.
 N47 Z100.
 N48 G0 Y100. Z-100.
 N49 G01 X-100. F500
 N40 Z100.
 N50 G28 XYZ
 M30
 %

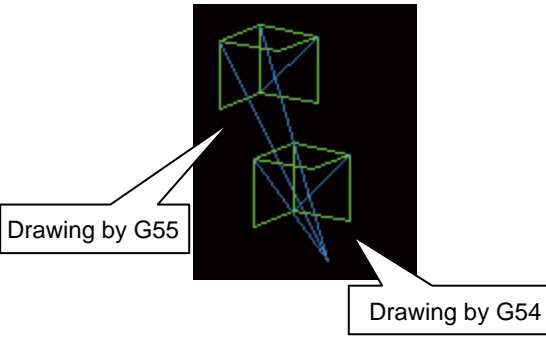
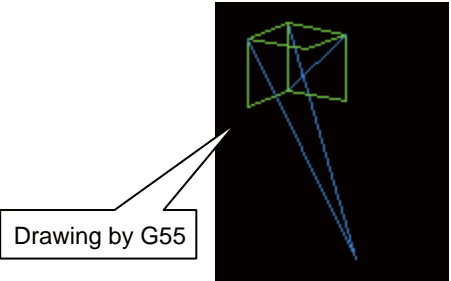
Drawing coordinate system selection	Drawing at 2D check	
All wk. coord		Workpiece coordinates G54 and G55 both are drawn.
Workpiece coordinate system G55		Workpiece coordinate G55 is drawn. G54 is not drawn.

4.3.5 Drawing during a Program Check

During the program check, the tool center path (machine position) is drawn. However, if a radius compensation is applied on the program being checked, the program path (tool position) and tool center path (machine position) are drawn. The colors of the lines displayed during the program check are expressed as follows.

		With radius compensation	Without radius compensation
Manual feed		-	-
Rapid traverse	Programmed path	White	-
	Tool center move path	Blue	Blue
Cutting feed	Programmed path	White	-
	Tool center move path	Green	Green

4.3.6 Changing the Display Range

The graphic drawing's scale can be enlarged or reduced, and the position moved or centered.

Operation method (Enlarging the and reducing the drawing)

- (1) Press the menu [Display range].



A white frame indicating the display range appears on the screen. The display range input mode is activated, and the following menu appears.

Zoom in	Zoom out	Up	Down	Left	Right	Centering			
---------	----------	----	------	------	-------	-----------	--	--	--

- (2) Press the menu [Zoom In] or [Zoom out].

The size of the white frame can be changed by using key operations.

To enlarge the drawing size: Press the menu [Zoom In] or [-] key.

To reduce the drawing size: Press the menu [Zoom out] or [+] key. A solid-line frame appears with respect to the original scale when enlarging, and a dotted-line frame appears when reducing.

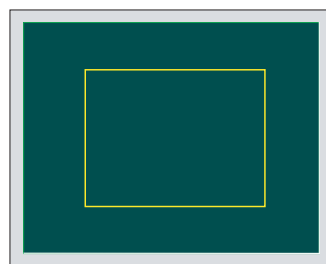

- (3) Press the [INPUT] key.



The display scale changes. By changing the display scale, the graphic data displayed on the screen is erased. When auto graphic is valid, the graphic data is automatically drawn again on the changed display scale.

Operation method (Changing the drawing display position)

- (1) Press the menu [Display range] .



A white frame indicating the display range appears on the screen. The display range input mode is activated, and the following menu appears.

Zoom in	Zoom out	Up	Down	Left	Right	Centering			
---------	----------	----	------	------	-------	-----------	--	--	--

- (2) Press the [Up] , [Down] , [Left] , [Right] menu or cursor movement keys keys [↑] , [↓] , [←] , [→] .

The cursor (□) indicating the center of the display and the frame line move up, down, left and right according to the key operations.

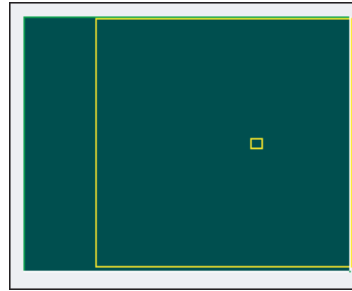

- (3) Press the [INPUT] key.



The display position changes so that the cursor position (□) is the center of the area. By changing the display position, the graphic data displayed on the screen is erased, however, the scale value is not changed.

(Note 1) When changing the display range while the 2-plane display mode such as [XY/XZ], the display range (scale and display position) for the upper and lower areas changes in the same manner. The operation method is the same as the 1-plane display mode.

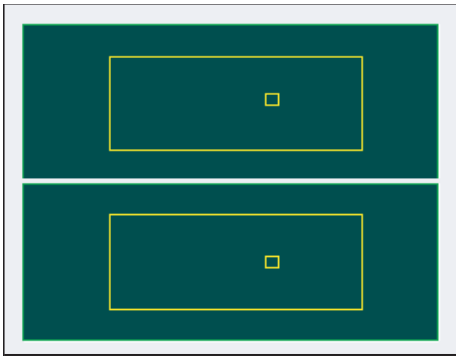

The white-framed display range in the upper and lower areas simultaneously move to the left/right when the [Left] , [Right] keys are pressed.

The white-framed display range of either upper or lower areas moves up and down when the [Up] , [Down] keys are pressed.

Which frame to be moved up/down can be changed with the page key.

(Note 2) The set displayed position will be held even after the power is turned OFF and ON again.

Operation method (Centering)

(1) Press the menu [Display range] .



A white frame indicating the display range appears on the screen.
The display range input mode is activated, and the following menu appears.

Zoom in	Zoom out	Up	Down	Left	Right	Centering			
---------	----------	----	------	------	-------	-----------	--	--	--

(2) Press the [Centering] .



The display position is changed so that the current machine position appears in the center of the drawing area.
When auto graphic is valid, the graphic data is automatically drawn again in the changed display range.

(Note 1) In the 2-plane display mode such as [XY/XZ], centering is applied for the upper and lower areas.
The operation method is the same as the 1-plane display mode.

(Note 2) When the [Centering] menu key is pressed after the display scale has changed, only the centering is applied without changing the scale value.

4.3.7 Changing the Display Mode

There are three types of graphic drawing mode: 1-plane, 2-plane, and 3-dimension. Press the menu [Display mode] key, and by selecting one of the following display mode menus, the axis configuration for each plane changes, and the menu display returns to normal. It is also possible to change the display mode by setting the axis name in the input area.

(Note 1) When the display mode is changed, the graphics displayed up to that point are erased.

(Note 2) These set display mode is maintained even after rebooting the machine.

(Note 3) The display mode can be set independently at the trace function and program check function.
These settings are not linked with one another.

(Note 4) The menu axis names XYZ are compatible with the basic axes IJK. X = base axis I, Y = base axis J, and Z = base axis K.

Display mode menu

Menu	Details	Type
XY	This changes to the 1- plane display mode configured of X-Y. The X-axis display in the horizontal axis, and the Y-axis displays in the vertical axis.	C
YZ	This changes to the 1- plane display mode configured of Y-Z. The Y-axis display in the horizontal axis, and the Z-axis displays in the vertical axis.	C
XZ	This changes to the 1- plane display mode configured of X-Z. The X-axis display in the horizontal axis, and the Z-axis displays in the vertical axis.	C
XY/XZ	Changes to 2-plane display mode composing X-Y, and X-Z. The X-axis display in the horizontal axis, and the Y-axis and Z-axis display in the vertical axis.	C
YX/YZ	Changes to 2-plane display mode composing Y-X, and Y-Z. The Y-axis display in the horizontal axis, and the X-axis and Z-axis display in the vertical axis.	C
XYZ	This changes to the three-dimensional display mode.A cube is displayed on the lower right of the screen.	C

Changing the display axis name

- (1) Set the axis name and press the [INPUT] key. ➔ XYZ appears the graphic display mode name.
 XYZ [INPUT] There are 3 drawing axes: X, Y, and C.

There are three types of display mode: 1- plane, 2- plane, and 3D. An image displays which display mode is currently selected. The selected axis name displays for the image axis name.

Display example

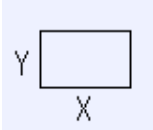
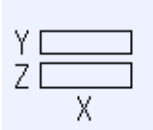
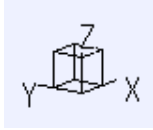
<1-plane> (XY)	<2-plane> (XY/XZ)	<3-dimension> (XYZ)
		

4.3.8 Changing the Display Angle

This is used to set the graphic drawing display angle when in 3-dimension display mode.
 Press the menu key or cursor keys to rotate the cubic displayed at the screen upper right and press the [INPUT] to set.

- (Note 1) When the display angle is changed, the graphics displayed up to that point are erased.
- (Note 2) The set display angle is maintained even after rebooting the machine.
- (Note 3) The display angle can be set independently at the trace function and program check function.
 These settings are not linked with one another.

Operation method

- (1) Press the menu [Rotate] . ➔ The mode changes to the rotation mode and the following menu appears.



- (2) Use the [Up], [Down], [Left], [Right] menu to adjust the display angle. ➔ Rotate the cubic display in the lower right of the screen using the operation keys.

The cursor movement keys ([↑], [↓], [←], [→]) can also be used to rotate.

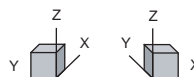

- (3) Press the [INPUT] key. ➔ The display angle changes.
 By changing the display angle, the graphic data displayed on the screen is erased.

(Note 1) The set display angle is maintained even after rebooting the machine.

4.3.9 Switching the Axis Movement Direction (+, -)

The path is drawn according to the axis movement direction designated by a base axis specification parameter "#1495 grf_ax_direction". The movement direction can be set for each axis.

When "#1495 grf_ax_direction" is set to 0, the axis movement directions are as follows.

<2D mode>

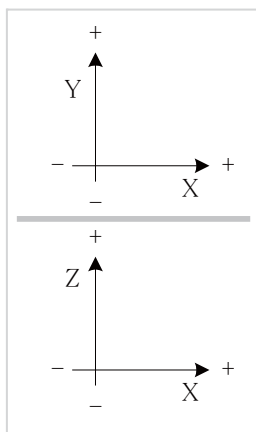
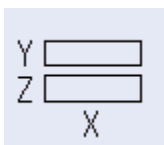

<3D mode>

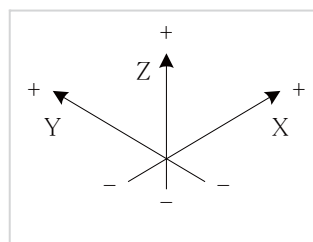
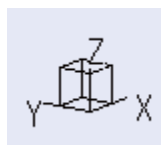

When the axis movement direction is opposite direction, the axis direction movement of 2D or 3D mode are as follow.
(Example) When the Yaxis movement direction is set in the opposite direction

<2D mode>

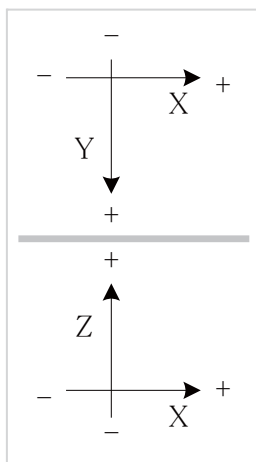
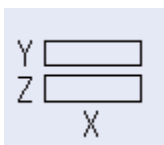

<3D mode>

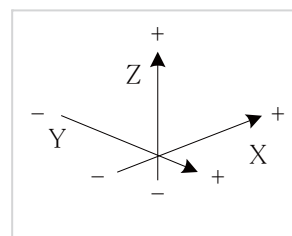
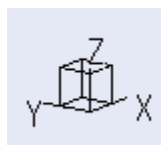

4.3.10 Switching to Full-screen Display Mode

Press the [All display] menu key to display the program check window on the whole screen. (full-screen display mode). Press this menu again to return the normal display.

Switching the display mode

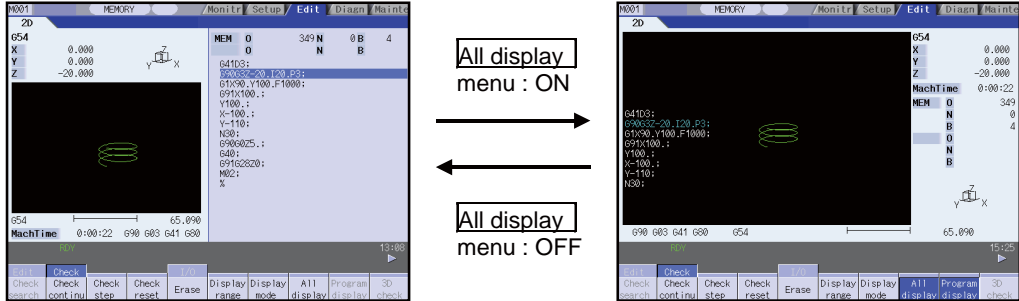

Normal display mode

Full-screen display mode

- (Note 1) The selected display mode is maintained even after rebooting the machine.
- (Note 2) The full-screen display mode is applied to the trace function and program check (2D solid) function commonly.
- (Note 3) When auto graphic is valid, the graphic is drawn after the drawing's scale is automatically adjusted to the scale to draw the entire machining program (the area of about 90% of the drawing area).

Displaying a program

When pressing the [Program display] menu key, the contents of the machining program on checking is displayed on the drawing area.

When pressing the [Program display] again, the displayed program is erased.

Note that this menu can be used only when the full-screen display mode is selected.

- (Note 1) The selected display mode is maintained even after rebooting the machine.
- (Note 2) The program display mode is applied to the trace function and program check (2D) function commonly.
- (Note 3) The [Program display] menu key cannot be selected while the normal display mode is selected. Program display mode is valid only when the full-screen display mode is selected.

4.3.11 Setting Auto Graphic

If [Auto graphic] is valid, a graphic is automatically drawn when a file is selected to check a graphic, the display size is switched (normal display <-> whole display), or the display range is changed.

When a file is selected, or the display size is switched, a graphic is drawn in the center of the drawing area after the scale is automatically adjusted so that the entire machining program can be drawn in the 90% of the drawing area.

A drawing path is switched according to the setting of parameter "#1231 set03/bit1, bit2".

Refer to "4.3.14 Switching the Draw Path" on how to operate.

(1) Press the menu [Auto Graphic].



The menu [Auto Graphic] is highlighted.

(2) Press the menu [Check search].



The check search list is displayed.

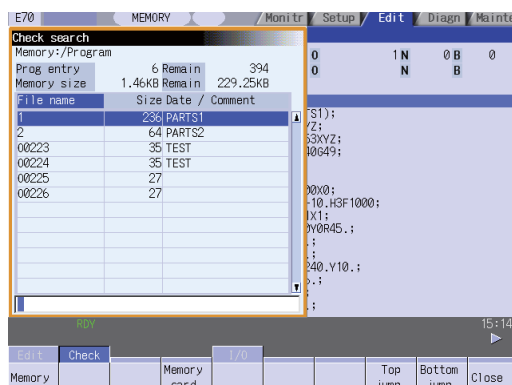

(3) Use the [↑], [↓], [PageUp], [PageDown] keys to point the cursor with the target machining program. (Or enter the target file name in the input area.)

(4) Press the [INPUT] key.



The check search is started.

A "Search completed" message appears when the search is completed.

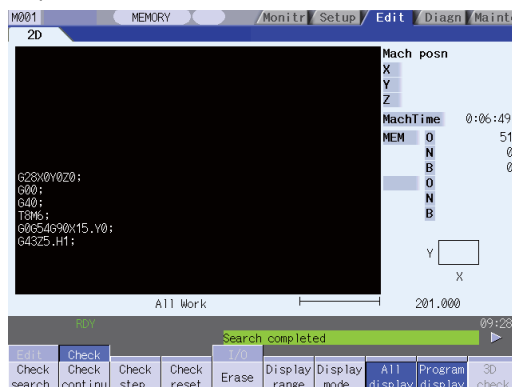

When the check search is completed, the graphic previously displayed is erased and the auto-adjustment of the scale will start.

During the auto-adjustment, a message "Executing auto scale" will be highlighted.

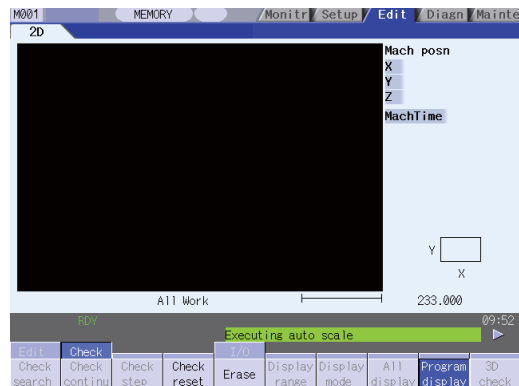

When the auto-adjustment of the scale is completed, "Checking" message is displayed and the graphic drawing is performed automatically.

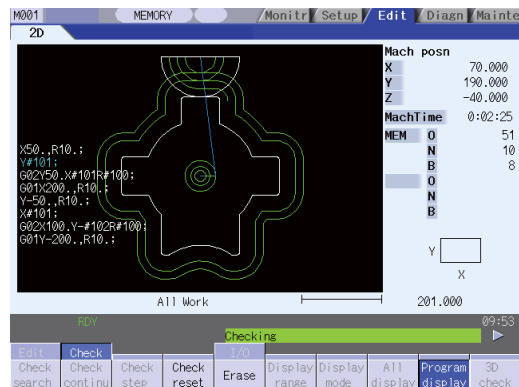

When the graphic drawing is completed, "Program check completed" message is displayed and the graphic drawing mode will be canceled.

Each menu is displayed normally, and the menu selection will be available.

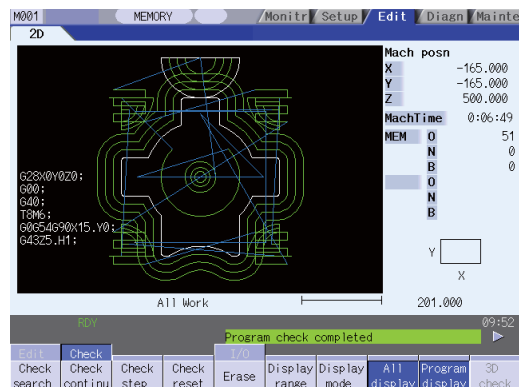

Precautions

- (1) Auto graphic is executed only for the 1-plane display mode. [Auto Graphic] menu cannot be selected for the other modes. Auto graphic mode always remains as it is in the 1-plane display mode.
- (2) Once the auto graphic mode is set, it is retained after the power is turned ON again.
- (3) Auto graphic cannot be set with a trace function.
- (4) Even M00 or M01 command does not cause "PROGRAM STOP".
- (5) If a program which contains M99 command is selected, auto adjustment of the scale will be executed repeatedly and the adjustment will not be completed with the "Executing auto scale" message blinking. Do not select a program which contains M99. Execute check reset when it happens.
- (6) When a large capacity program is selected, it may take time to perform the auto graphic.
- (7) If a displayed position for a figure is changed due to change in display range, a graphic drawing will not be performed automatically.
Auto graphic drawing is performed only when the figure is enlarged or reduced.
- (8) If a check search is performed on a file which went through an auto-adjustment of the scale, only graphic drawing will be performed as long as there is no changes in "a path and a file name (including a device)", "the date of updating", or display mode (XY/YZ/XZ.. etc).
However, a maximum of 12 files to which an auto-adjustment of the scale has been executed, can be memorized.
- (9) Auto adjustment of the scale will be interrupted if one of the following operations is taken:
 - Press the [Check reset] menu;
 - Press the [Auto Graphic] menu;
 - The screen is changed to other than [2D check];
 - A program error occurs.

4.3.12 Availability of Check Mode with Other Functions

It is important to be aware that certain NC parameters, program commands, and machine operation panel switches cannot be used while performing a program check.

Function name	Remarks
Decimal point programming	Both decimal point input type I and II are valid.
Z-axis command cancel	Signals are ignored and a check drawing is made.
Interlock	Signals are ignored and a check drawing is made.
External deceleration	Signals are ignored and a check drawing is made.
Override	Signals are ignored and a check drawing is made.
Auto operation pause (feed hold)	Signals are ignored and a check drawing is made.
Auto operation start-up (cycle start)	"M01 Operation alarm (0112)" occurs if automatic operation is started up while the check drawing is being made.
Auto-restart	The check is completed at M02/M30 and is not restarted.
Manual mode/handle	The mode can be changed to manual or handle mode and the machine can be moved even during the check. However, this is not reflected to the check drawing position.
F1-digit feed	The speed command does not influence the check drawing.
User macro I, II	Basic variable calculations, decisions and branch functions are all enabled. However, the following functions are ignored, or indefinite values are input. Macro interface input/output, Single block stoppage, Miscellaneous function complete signal waiting control, Feed hold, Feedrate override, G09 enabled/disabled control, Reading of position information for other than the previous block end point coordinates
M, S, T and 2nd miscellaneous function commands	M, S, T and 2nd miscellaneous function command signals commanded by the program during the check are not output. Neither do they display on the Operation screen etc.
G command modal	G modal displays on the modal display screen while the check drawing is being made.
Tool compensation amount	The check drawing is made with the tool compensation amount set when starting the check drawing.
Workpiece coordinate system offset amount	The check drawing is made with the workpiece coordinate system offset amount set when starting the check drawing. The display data is not changed when changes are made with G10 or system variables.
Parameter	The setting values when starting the check drawing are used. Parameters are changed to command values when changing the parameters using G10.
Optional block skip	The setting status when starting the check drawing are used.

(Note) Reference position return and start position return

The reference position return command and start position return command are valid, but actual machine motion (trace display) is partially different from the drawing by program check. As shown in the figure below, when returning to the reference position via the intermediate point with the G28 or G30 command, positioning to the intermediate point is done by a straight line and positioning from there to the reference position is done by each axis independently.

With the G29 command, positioning to the intermediate point is done by each axis independently.

Under program checking, however, positioning is always done by a straight line even when returning via the intermediate point; this may cause a little difference from the trace display.

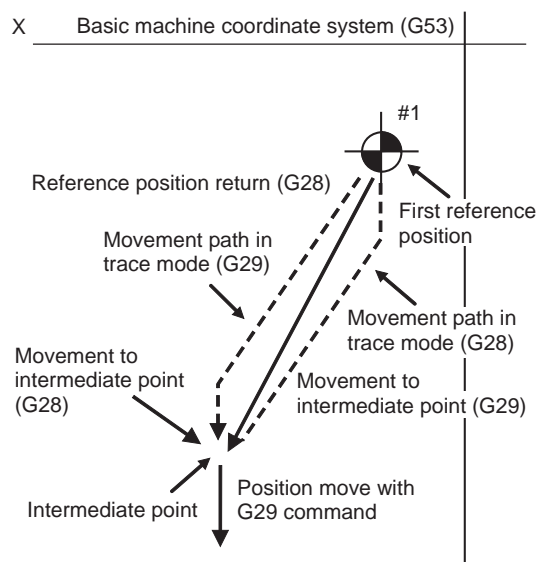

4.3.13 Handling of Variable Commands, Programmable Parameter Input, and Programmable Compensation Data Input

If a program check is performed for a machining program for which the variable command data etc. is rewritten, all data types are treated as shown in the following table after completion.

Data type	Saving data before program check	Explanation
Parameter	x	The programmable parameter input commands are set as actual data. (The data before the check is not saved.)
Local variable	○ / x	It is possible to return to the status prior to starting the program check based on the "#1231 set03(bit0)" graphic check interchangeable parameter value. 0:Returns to original status after check completion 1:Does not return to original status after check completion
Common variable	○ / x	
Workpiece coordinate system offset	○ / x	
Tool compensation amount	○ / x	

4.3.14 Switching the Draw Path

Drawn path can be switched by designating a parameter.

Drawn path is switched by combination of "#1231 set03/bit1" and "#1231 set03/bit2".

#1231	set03/bit1	
	0	1
set03/bit2	0	Tool center move path (machine position) and programmed path (tool position) (Note1)
	1	Tool center move path (machine position) Programmed path (tool position) (Note1)

(Note1) A programmed path does not reflect the radius compensation.

The counter display is switched by combination of "#1231 set03/bit1" and "#1231 set03/bit5". When the drawing coordinate system by the menu [Drawing system] is set for other than "All wk. coord", the counter of the workpiece coordinate position or the tool position (workpiece coordinate system) is displayed regardless of a parameter "#1231 set03/bit5".

#1231	set03/bit5	
	0	1
set03/bit1	0	Machine position Workpiece coordinate position (Note2)
	1	Tool position (machine coordinate system) Tool position (workpiece coordinate system) (Note2)

(Note2) The name of the counter display is changed according to the currently executed workpiece coordinate system.

4.3.15 Notes for Program Check (2D)

Check function

- (1) The check function draws while referring only to the NC internal operation results. Thus, the path is not drawn for commands requiring machine movement.
- (2) Check search and check start are not possible during automatic start or automatic pause. The operation message "Executing automatic operation" appears.
- (3) Operation search is possible for a program with 32 or less file name characters.
- (4) Graphic check is not available for MDI program.

Notes for checking (Common for continuous check and check step)

- (1) When the menu [Zoom in] , [Zoom out] , [Display mode] , [Rotate] or [Display range] key is pressed while checking, the graphic data is erased, however, the program check is not interrupted.
- (2) Drawing is continued even after changing to another screen while checking.
- (3) Refer to "4.3.13 Handling of Variable Commands, Programmable Parameter Input, and Programmable Compensation Data Input" for further details on all types of data set in the program while checking.
- (4) Checking the program stops if there is a M00/M01 command. However, when executing the M01 command, drawing is stopped regardless of the ON/OFF status of the optional stop switch signal.
- (5) Automatic operation cannot be performed even if the automatic operation button is pressed while checking. "M01 Program check mode 0112" occurs. Execute automatic start after the check is completed or after the check is interrupted by pressing the [Check reset].
- (6) The contents of ONB display and buffer display in the check screen during automatic operation are the contents of the program during automatic operation. The contents of ONB display and buffer display in the operation screen during check execution are the contents of the program during check execution.
- (7) When operation search or check operation ("Check continu" or "Check step") is performed during program restarting, the operation message "in program restarting" is displayed, and the program will not be searched or graphically checked.
- (8) If it is switched to manual operation mode during checking, the error "M01 Program check mode 0112" will occur and axis cannot be moved. To move it, cancel the checking using reset ([Check reset] menu or NC reset). An alarm will be cancelled after switching to memory mode from manual operation mode. Checking can be continued with the alarm.
- (9) If origin set operation is executed during check, workpiece coordinate counter becomes an origin set value. However, the coordinate system will return to the value before check after the completion of checking or reset ([Check reset] menu or NC reset) is pressed.

Notes for ending check

- (1) If an M02/M30 command is found, "Program check completed" occurs.
- (2) By performing commands such as a check reset or turning the trace display ON, the check mode is exited. Clear the errors with these operations in the case of a program error.

Notes for switching between trace mode and check mode

- (1) The checking mode is released when the trace mode becomes ON. It is also released series if NC reset is executed.
- (2) Graphic check (2D) cannot be performed during the trace mode.
- (3) When trace window is displayed during check, check will be terminated.

4.4 Program Input/Output



The machining program can input/output between the NC internal memory and the external input/output device. The hard disk inside the NC unit is also treated as an external device.

(Note) When the program input/output function is used, set the parameter "#8923 Hide Edit-IO menu" to "0".

This function applies to the devices as follows.

- Memory
- Serial
- Memory card (CF card)
- USB memory
- Ethernet

<During file transmission>

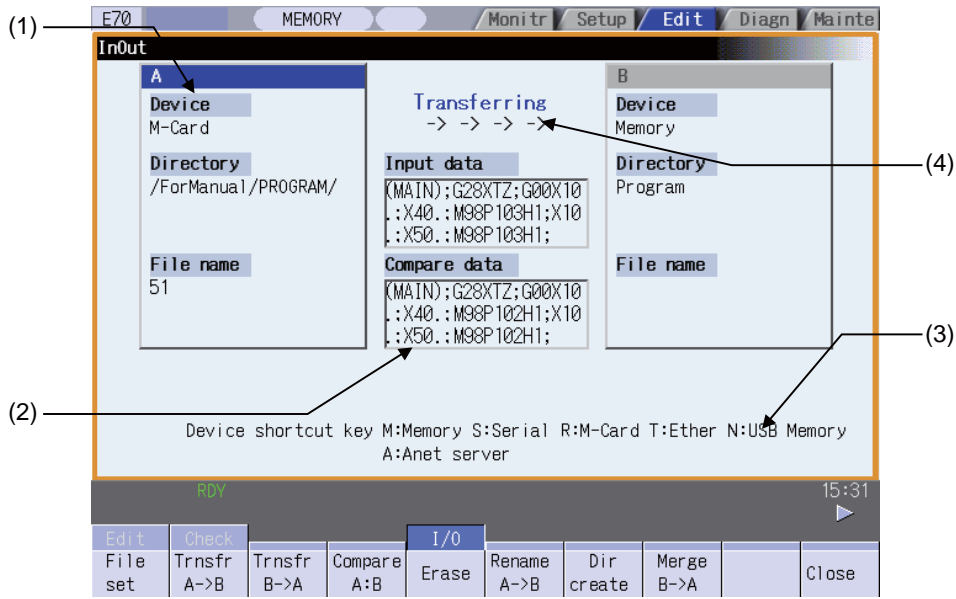

<During file setting>

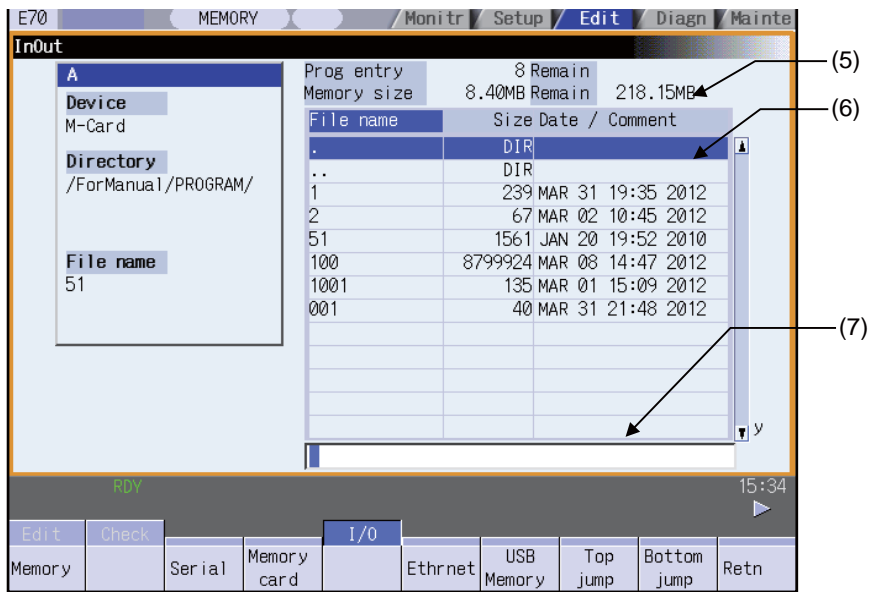

Display items

Display item	Details
(1) Device, directory, file name setting area	This sets the device, directory, and file name for which the transmission, compare, and erase functions are used. When the number of characters exceeds the display possible number (directory:63, file name:42), the excess is not displayed. As for the device and directory, the setting values are retained even when the power is turned OFF. (Note 4)
(2) Input/compare data display	This displays data that is being transferred or compared. If an error occurs while comparing data, the block for which the error occurred displays.
(3) Guidance display area	This displays the device name shortcut key.
(4) Process progress display section	This displays the details and data input/output direction for the process currently being performed.
(5) Capacity display section (Note 1)	This displays the file (machining program) registration count information and memory capacity information for the selected device. Number of programs registered: This displays the file (machining program) registration count. Remainder: This displays the remaining file registration count. This displays only when the memory is selected. Number of memory characters: This displays the memory character count. Remainder: This displays the remaining character count.
(6) List display section	This displays the device A or B directory contents list (directory and file name). File name: This displays the file (machining program) name. Size: This displays the file size. <DIR> displays in the case of the directory. Date/comment: The file comment (max. 17 characters) displays in the case of the memory device. The file update data displays in the case of memory card, USB memory or Ethernet devices.
(7) Input area	This displays the input key.

(Note 1) Some items may not be displayed depending on the device.

Display item	Device				
	Memory	Serial	Memory card	USB memory	Ethernet
Number of programs registered	○	×	○	○	○
Remainder	○	×	×	×	×
Number of memory characters	○	×	○	○	○*
Remainder	○	×	○	○	×
List	○	×	○	○	○

○ : Displayed × : Not displayed

- When the Ethernet parameter "#97*1 Host n no total siz" is set to 1, the number of host memory characters will not appear.

(Note 2) When the device is not mounted, a registration count and a memory capacity are not displayed and an empty list is displayed.

(Note 3) When the device is serial, an empty list is displayed.

(Note 4) When the number of characters in the directory path (full path) from the root directory exceeds 100, the directory path is not retained, but a previously set directory path containing 100 characters or less retained. When the device is "Memory", the initial directory display is "Program". When the device is "Ethernet", the initial directory display is "/" (root).

Menus

Menu	Details	Type	Reference
File set	This sets the device, directory and file name for which input/output operations are performed. (Note) When the device is serial or nothing, an empty list is displayed. When the device is not mounted, an operation message "(Device name) not ready" appears.	A	4.4.2 Selecting a Device, Directory, and File
Transfr A→B	This copies the file in file setting column A file to file setting column B. (The originally transferred file is not affected.)	A	4.4.3 Transferring a File
Transfr B→A	This copies the file in file setting column B file to file setting column A. (The originally transferred file is not affected.)	A	
Compare A:B	This compares the files in file setting column A and file setting column B.	B	4.4.4 Comparing Files (Compare)
Erase	This erases the selected file in file setting column.	A	4.4.5 Erasing a File
Rename A→B	This changes the name of the file in file setting column A to that of in file setting column B. (Note)The same device must be selected for A and B.	A	4.4.6 Changing a File Name (Rename)
Dir create	This creates a new directory in the selected file setting column. The directory can be created when memory card or USB memory is selected for the device.	A	4.4.7 Creating a Directory
Merge B→A	This adds the file contents of file setting column B to file setting column A. (The file setting column B file is not affected.)	A	4.4.8 Merging a File
Close	This closes the pop-up window and quits this function.	C	
MemCrd format	The formats the memory card (front IC card).	A	4.4.9 Formatting an External Device
USB Mem format	This formats the USB memory.	A	
Halt	This interrupts the process (transfer, compare, etc.) during its execution.	C	

4.4.1 Changing the Valid Area

It is necessary to enable the areas including device, directory, and file name in the file setting column A or B in order to set those items.

Change the display area using the [←],[→], direction cursor keys or the [| ←], [→ |] tab keys

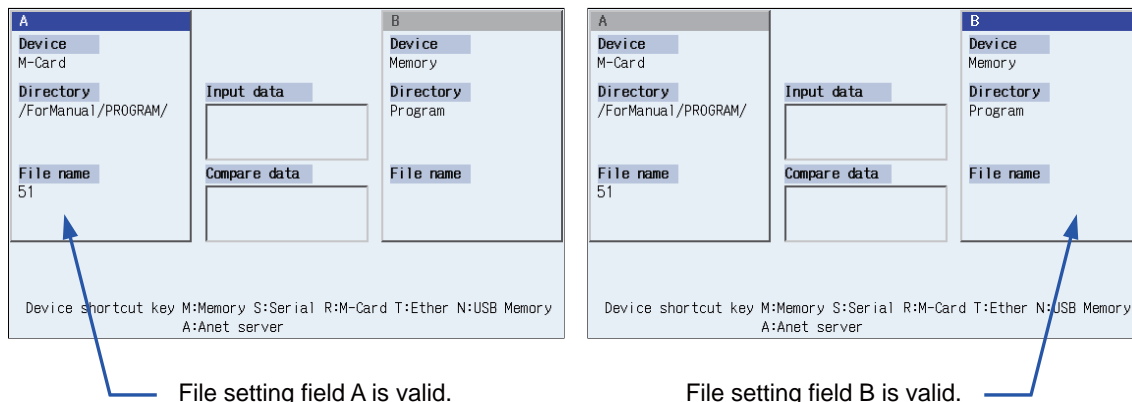

Changing file setting column B to a valid area (refer to upper right diagram)

- (1) Press the [→] or [→|] key ➡ File setting column B changes to a valid area.

Changing file setting column A to a valid area (refer to upper left diagram)

- (1) Press the [←] or [|←] key. ➡ File setting column A changes to a valid area.

4.4.2 Selecting a Device, Directory, and File

This section explains the file device, directory, and file name specification methods for the file transfer and erase commands etc. performed on this screen.

File operation procedure

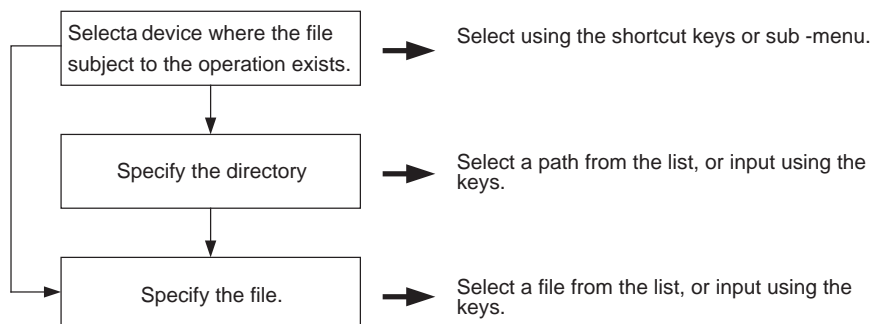

Outline of device, directory, and file name designating methods

Device	Designation target file	Designation method		
		Device	Directory	File name
NC memory	- Machining program - User macro program - Fixed cycle program	Select from the submenu	- (Default)	Key input in the input area, and then [INPUT]
		Designate using the shortcut key.		Select from the list
Device other than the NC memory	All files	Select from the submenu	Key input in the input area, then [INPUT]	Key input in the input area, and then [INPUT]
		Designate using the shortcut key.	Select from the list	Select from the list

- (1) The device can be selected using the sub-menu or shortcut keys.
(The devices that can be used will differ depending on the specifications.)
- (2) One of the following methods can be used to designate the directory (for devices other than the NC memory) and file name.
 - Designate the directory path or file name in the input area and press the [INPUT] key.
 - Move the cursor in the list display section to the target directory or file name and press the [INPUT] key. A wildcard (*) can be used for the file name.

(Note) When the number of characters of directory path (full path) exceeds 128, changing directories cannot be performed.

Notes when selecting a file

- (1) During directory and file name setting, the designated directory, path or file name will be set, even if it does not actually exist. This will not cause an error. Note that the previously set directory is overwritten.
- (2) When selecting a fixed cycle program, it is necessary to set the basic common parameter "#1166 fixpro". Furthermore, select "Memory" for the device, and "Program" for the directory.

Initial directory when the Ethernet is selected

An initial directory is specified at turning the power ON by the following parameter.

- #9706 Host No.
- #9714 Host1 directory
- #9734 Host2 directory
- #9754 Host3 directory
- #9774 Host4 directory

Operation method (Selecting an NC memory program)

- (1) Press the [M] short cut key. ➔ The device name changes to "Memory".
"Program" appears in the directory.
- (2) Press the menu [File set] . ➔ The NC memory program list and input area appear.

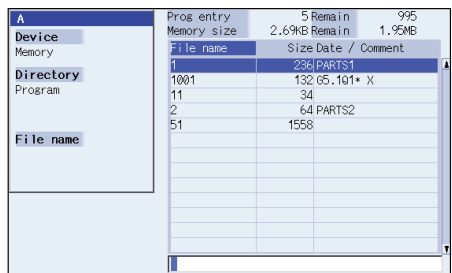

The menu appears as follows.

<First page>

Memory		Serial	Memory card		Ethernet	USB Memory	Top jump	Bottom jump	Retn
--------	--	--------	-------------	--	----------	------------	----------	-------------	------

<Second page>

Comment nondisp		Program	Program all				List update	Sort change	Retn
-----------------	--	---------	-------------	--	--	--	-------------	-------------	------

By pressing the operation menu at this point, it is possible to change the device.
When the menu [Program] or [Program all] is selected, the setting of "File name" column is cleared.
When the device is only the memory, the menu [Program] or [Program all] is valid.

When selecting the file name from the list

- (3) Move the cursor to the file name to be selected, and fix.
[↑], [↓] [INPUT]

- ➔ The selected file name appears.
The list and input area are cleared, and the screen returns to the original display.
The menu returns to its original display.

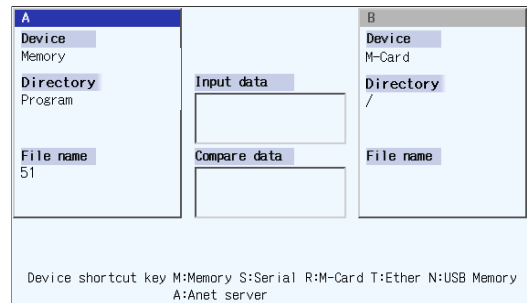

When inputting the file name from the input area:

- (3) Input the file name.
10013 [INPUT]

- ➔ The input file name appears. The list and input area are cleared, and the screen returns to the original display. The menu returns to its original display.

Designating multiple files

A wildcard (*) can be used for the file name.

By using a wildcard, multiple files can be transferred, compared, and erased at one time.

[Ex. 1] When programs 1 to 1000 exist in the NC memory.

Designate "*" in the file name: The target program is "1 to 1000".

Designate "*.*" in the file name: There is no target program.

Designate "1*" in the file name: The target program is "1, 10 to 19, 100 to 199, 1000".

Designate "1*.*" in the file name: There is no target program.

Designate "**1" in the file name: The target program is that where the position of the 1 is "1".

(1, 11, 21, 31,101, 111,981, 991)

Designate "**1*" in the file name: The target program is all of the programs containing "1".

(1, 10 to 19, 21, 31,100 to 199, 201, 210,981, 991, 1000)

Designate "1*1" in the file name: The target program is "11, 111, 121, 131, 141, 151, 161, 171, 181, 191".

[Ex. 2] When programs 1.PRG to 1000.PRG, and 1 to 1000 exist in the HD.

Designate "*" in the file name: The target program is "1 to 1000".

Designate "*.*" in the file name: The target program is "1.PRG to 1000.PRG".

Designate "1*" in the file name: The target program is "1, 10 to 19, 100 to 199, 1000".

Designate "1*.*" in the file name: The target program is "1.PRG, 10.PRG to 19.PRG, 100.PRG to 199.PRG, 1000.PRG".

Operation method (Selecting a file from a device other than the NC memory)

- (1) Press a device selection shortcut key.
(Example) [R] → The device name changes to "Memory Card". The root directory (/) appears in the directory.
- (2) Press the menu [File] set . → The Memory Card program list and input area appear.

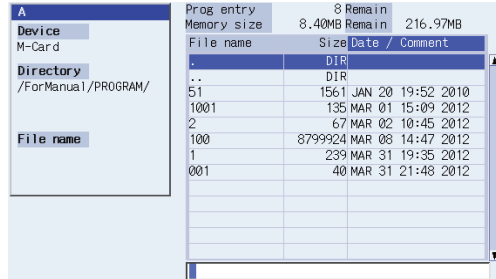

A menu similar to the following appears.

<First page>

Memory		Serial	Memory card		Ethernet	USB Memory	Top jump	Bottom jump	Retn
--------	--	--------	-------------	--	----------	------------	----------	-------------	------

<Second page>

Comment nondisp		Program	Program all				List update	Sort change	Retn
-----------------	--	---------	-------------	--	--	--	-------------	-------------	------

By pressing the operation menu at this time, the device can be changed.
When the device is only the memory, the menu [Program] , [Program all] are valid.

When selecting a directory from the list.

- Move the cursor to the directory to be selected and fix.
 - (3) [↑], [↓] [INPUT] → The directory selected in the directory column appears. The contents of the selected directory appear in the list. Select "." to move to one directory above. There is no change when "." is selected.
- Repeat this operation until the cursor arrives at the target directory.
Next, refer to operation (4).

When inputting a directory from the input area:

- (3) Input the directory path. → The input directory path appears in the directory column.
- (Example) /PRG/PRECUT [INPUT]

When selecting the file name from the list.

- Move the cursor to the file name to be selected and fix.
- (4) [↑], [↓] [INPUT] → The file name selected in the file name column appears. The list and input area are cleared, and the screen returns to the original display. The menu display returns to normal.

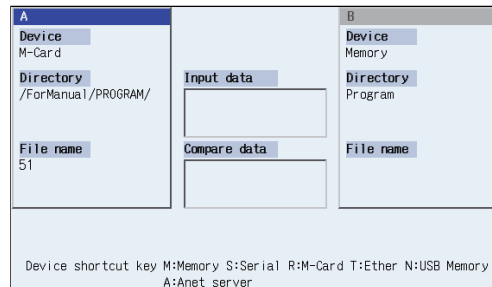

When inputting a file name from the input area:

- (4) Input the file name.10013.PRG [INPUT] → The file name input in the file name column appears. The list and input area are cleared, and the screen returns to the original display. The menu display returns to normal.

4.4.3 Transferring a File

This section explains the method used to transfer files between different devices, or between the same device. Refer to "4.5.2 Selecting a Device, Directory, and File" for details of the device, directory, and file specification method.

Operation method

- (1) Use the [←] or [| ←] key to select file setting column A.
- (2) Designate the transfer source device, directory and file name. ➡ The designated file displays in file setting column A. A wildcard "*" can be used for the file name to designate multiple files.
- (3) Use the [→] or [→ |] key to select file setting column B.
- (4) Designate the transfer destination device, directory and file name. ➡ The designated file appears in file setting column B.
- (5) Press the menu [Transfr A → B] . ➡ A message appears to confirm the transfer.
Press the menu [Transfr B → A] when transferring from device B to device A.
- (6) Press the [Y] or [INPUT] key. ➡ File transfer is commenced. The process progress display area displays message indicating that transfer is in progress, and also indicates the transfer direction. Furthermore, the data being transferred appears in the input/comparison data display area of the input data display column.

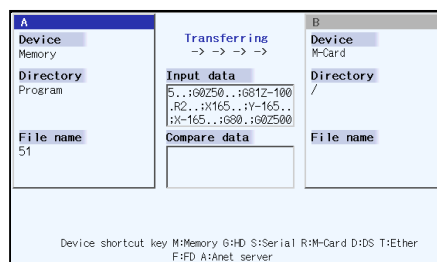

A message appears indicating a transfer completion after transfer has been completed.

CAUTION

⚠ " ; ", "EOB", "%", and "EOR" are symbols used for explanation. The actual codes for ISO are "CR, LF" ("LF") and "%".

The programs created on the Edit screen are stored in the NC memory in a "CR, LF" format, however, the programs created with external devices such as the FD or RS-232C may be stored in an "LF" format.

The actual codes for EIA are "EOB (End of Block)" and "EOR (End of Record)".

⚠ To prevent the influence of data loss and data transformation over the line, always carry out data comparison after transferring a machining program.

Notes (Notes related to transferring in general)

- (1) Depending on the type of file, some data cannot be transferred during automatic operation. Do not transfer during automatic operation.
- (2) When the capacity of the transfer destination is reached during file transfer, only the data transferred up to that point is registered as a file, and an error will occur.
- (3) During input to the NC memory or comparison, if the file format size on the NC memory side differs from the other side file format size (when the maximum number of registrations differs between the NC memory and the other side), processing is carried out matching the smaller size.
(Ex. 1) If a format size of 200 files is input for a format size of 1000 NC files, 200 files are registered.
(Ex. 2) If a format size of 1000 files is input for a format size of 200 NC files, the files up to the 200th file are registered and an error message appears. (The remaining files are not registered.)
- (4) Up to 223 files, including the directory, can be registered in the FD's root directory.

Notes (Notes when transferring machining program files)

- (1) For the serial, always set both ends of the "EOR" code at the head and end to feed (NULL). If "EOB" etc., is directly after "EOR", the operation may not be executed normally due to the input buffer influence during the next input operation.
- (2) The transfer speed is slower if there are many registrations.
- (3) The size of one block of the machining program to be transferred should be 250 characters or less.
- (4) The characters that can be used for the file name and directory path are 1-byte number, 1-byte capital alphabetical letters, and 1-byte symbols recognized by the system.
Note that the following characters cannot be used.
, /, :, ", " (comma), *, ?, ", <, >, a to z (small letters), Space
Up to 32 characters are allowed for the file name to create in or transfer to NC memory.
- (5) If the file whose name includes lower case alphabet is transferred to NC memory, the lower case letter will be converted into the capital letter.
- (6) When using tape, carry out parity V adjustment to improve the reliability of the tape format. Then use it with the input/output parameter "Parity V" validated.
- (7) When the machine tool builder macro and fixed cycle program are input, change the program type with the parameter (#1166 fixpro). Also, set the device and directory as follows.
Device: Memory, Directory: Program
- (8) Transferring or verifying the multiple files between the external device connected serially and that other than the serial connection.
- (9) With machining program created by the MELDAS500 Series or earlier model, "EOB" is registered as "LF". However, when these programs are stored in the E70 Series NC memory, "EOB" will be converted to "CR LF", and the number of characters will increase. Thus, when all of the machining programs output from an MELDAS500 Series or earlier model, having the same specifications as the maximum memory capacity, are stored in the E70 Series NC memory, the memory capacity may be exceeded.
- (10) When the file to be transferred (input) is running or in "program restarting" mode, the operation message "Executing automatic operation" or "Program restarting" is displayed and file will not be transferred (input).
- (11) If the file to be transferred (input) is being edited in the custom screen, the operation message "Can't write into being edited file" appears and may not be transferred (input).

- (12) When "#8936 Delete leading 0" is set to "1", if a file name consisting only of numerical figures is input, "0" at the head of the file name is deleted to be checked. However, if the file name is out of the range between 1 and 99999999, the leading "0" is not deleted. This applies to a machine tool builder's macros. Therefore, for example, while the program "1" is in automatic operation, if a file name to transfer (input) is named "0001", the operation message "Executing automatic operation" will be displayed, and transfer cannot be carried out. In the case of fixed cycles, regardless of the setting of "#8936 Delete leading 0", the name of the file to transfer must be 9 digits, and it must not start from "0". Attempting to transfer a file whose name does not satisfy the conditions above will cause an error.
- (13) If a file to be transferred (input) is subject to edit lock (Edit lock B: 8000 to 9999, Edit lock C: 9000 to 9999), the operation message "Edit lock B" or "Edit lock C" will appear and it cannot be transferred.
If "#8936 Delete leading 0" is set to "1" and the program name consisting only of numerical figures is input, "0" at the head will be deleted and checking will be performed. (Example: If the transferring (inputting) file name is "008000", the operation message "Edit lock B" will be displayed and it cannot be transferred.)
- (14) The transfer range from the external device other than serial to NC memory will change depending on the value set in the user parameter "#19006 EOR Disable".
- When the user parameter "#19006 EOR Disable" is set to "0", the head line will not be transferred. Up to "%" in the second line onward will be transferred, and data after "%" will not be transferred. If there is no "%", all data will be transferred.
 - When the user parameter "#19006 EOR Disable" is set to "1", all file contents will be transferred.

4.4.4 Comparing Files (Compare)

This chapter explains method used compare files after transferring.

Refer to "4.5.2 Selecting a Device, Directory, and File" for details of the device, directory, and file specification method.

Operation method

- (1) Use the [←] or [| ←] key to select file setting column A.
- (2) Designate the device, directory and file name to be compared. ➡ The designated file name appears in file setting column A.
- (3) Use the [→] or [→ |] key to select file setting column B.
- (4) Designate the other device, directory and file name to be compared. ➡ The designated file name appears in file setting column B.
- (5) Press the menu [Compare A:B]. ➡ The file comparison starts. The input data and comparison data appear in the input/comparison data display area. A message appears when the comparison is completed. If a comparison error occurs, the block with the error is displayed in the comparison data display column on the screen.

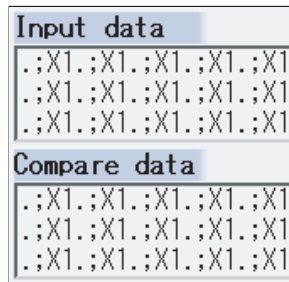

- (Note 1) Files that can be compared are text files only. Correct outcome will not be obtained through binary file comparison.
- (Note 2) In a file comparison, even if "#8936 Delete leading 0" is set to "1", when comparing one separate file that contains one program, "0" at the head of the program name is not deleted. Designating the file name is required. However, in the case of serial/batch file, comparison is carried out with deleting "0" at the head of the program.

4.4.5 Erasing a File

This chapter explains the method used to erase files.

Refer to "4.5.2 Selecting a Device, Directory, and File" for details of the device, directory, and file specification method.

Operation method (Erasing a file in file setting column A)

- | | | |
|-----|---|---|
| (1) | Use the [←] or [←] key to select file setting column A. | |
| (2) | Designate the device, directory and file name to be erased. | ➡ The designated file appears in file setting column A. |
| (3) | Press the menu [Erase] . | ➡ A message to confirm the erasing appears. |
| (4) | Press the [Y] or [INPUT] key. | ➡ The file is erased.
A message appears when the erasing is completed. |

(Note 1) If the file to be erased is running, an error will occur, and the file will not be erased.

(Note 2) If the file to be erased is being edited in the custom screen, the operation message "Can't erase designated file" appears and may not be erased.

Operation method (Erasing a file in file setting column B)



Use the [→] or [→ |] key to select file setting column B, and designate the device, directory, and file name for file setting column B. Following this, the operation method is same as for "Erasing a file in file setting column A".

4.4.6 Changing a File Name (Rename)

This section explains the method used to change the file name.

Refer to "4.5.2 Selecting a Device, Directory, and File" for details of the device, directory, and file specification method.

(1) Changing a file name

- (1) Use the [←] or [| ←] key to select file setting column A.
- (2) Designate the device, directory and file name before the change.  The designated file appears in file setting column A.
- (3) Use the [→] or [→ |] key to select file setting column B.
- (4) Designate the device, directory, and file name after the change.  The designated file appears in file setting column B.
- (5) Press the[Rename A → B] menu.
- (6) Press the [Y] or [INPUT] key.  Renaming of the file starts. A message appears when the renaming is completed.

(Note 1) Make sure the original and new devices are the same.

(Note 2) If the file to be renamed is running or program restarting, an error will occur, and the name will not be changed.

(Note 3) If the file to be renamed is being edited in the custom screen, the operation message "Can't rename designated file" appears and may not be changed.

(Note 4) If a file that does not exist is designated for the original file, or if an existing file name is designated for the new file selection, an error occurs, and the name is not changed.

(Note 5) The directory where the file in operation search/check search is stored cannot be renamed. The operation message "Can't rename designated file" appears.

4.4.7 Creating a Directory

This section explains the method used to newly create a directory.

Refer to "4.5.2 Selecting a Device, Directory, and File" for details of the device, directory, and file specification method.

Operation method

- (1) Use the [←] or [| ←] key to select file setting column A.

- (2) Designate the device



The designated device name appears. USB memory and memory card is the device to make directory.

- (3) Select a directory to be newly created from the list, or designate by inputting from the input area.



The designated details appear.

File name	Size	Date	Comment
DIR			
..			
51	1561	JAN 20 19:52	2010
1001	135	MAR 01 15:09	2012
2	67	MAR 02 10:45	2012
100	8799924	MAR 08 14:47	2012
1	239	MAR 31 19:35	2012
001	40	MAR 31 21:48	2012

- (4) Set the new directory in the input area and press [INPUT] key.



The set directory name appears.

- (5) Press the [Dir create] menu.



The directory is created.

The directory can also be created in file setting area B.

- (Note 1) Make sure that the directory path is less than 100 characters. When the path exceeds 100 characters, it cannot be recognized as a path.

4.4.8 Merging a File

This section explains the method used to add a file in file setting column B to a file in file setting column A. Refer to "4.5.2 Selecting a Device, Directory, and File" for details of the device, directory, and file specification method.

Operation method

- (1) Use the [←] or [| ←] key to select file setting column A.
- (2) Designate the merge destination device, directory, and file name. ➡ The designated file name appears in file setting column A.
- (3) Use the [→] or [→ |] key to select file setting column B.
- (4) Designate the merge source device, directory, and file name. ➡ The designated file name appears in file setting column B.
- (5) Press the menu [Merg B → A] . ➡ A message confirming the merge appears.
- (6) Press the [Y] or [INPUT] key. ➡ The file merge starts. The data being merged appears in the input/comparison data display area input data display column. Furthermore, a message indicating that merging is being performed, and an arrow from the merge source (file setting column B) to the merge destination (file setting column A) display in the process progress display area.

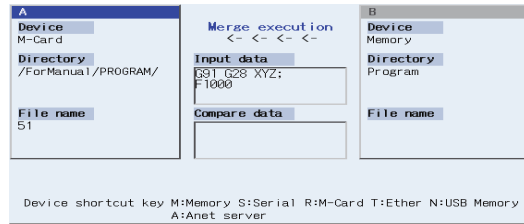

A message appears when the merge is completed. The details of the file in file setting column A will be as follows when the merge is completed.

<pre>(FILE A) G28 XYZ G90 F800 G00 X100. Y100.; (FILE B) G91 G28 XYZ F1000; G01 X200. Y200.; M02; %</pre>	} Details of file in file setting column A before merge.
<pre>(FILE B) G91 G28 XYZ F1000; G01 X200. Y200.; M02; %</pre>	} Details of file in file setting column B before merge.

The details of the file in file setting column B do not change.

- (Note 1) If the merge destination file (file in file setting column A) is running, an error will occur, and the files will not be merged.
- (Note 2) If the merge destination file (file in file setting column A) is being edited in the custom screen, the operation message "Can't write into being edited file" appears and may not be changed.
- (Note 3) The devices that can be merged are the memory, memory card and USB memory.

4.4.9 Formatting an External Device

This section explains the method to format the external devices.

Operation method (Formatting a memory card)

- | | | |
|--------------------------------------|---|--|
| (1) Press the menu [MemCrd format] . | ➔ | A message confirming the formatting appears. |
| (2) Press the [Y] or [INPUT] key. | ➔ | The memory card is formatted.A message appears when the formatting is completed. |

(Note 1)The memory card is formatted with FAT16.

(Note 2)The volume label is set when the memory card is formatted.

Operation method (Formatting a USB memory)

First, press [USB format]. Refer to "Formatting a memory card" for more details.

(Note 1) USB memory is formatted with FAT16.

(Note 2) Only the DS formatted with FAT16 can be used.

4.4.10 List of File Names

There is a directory for each type of data in the NC memory.

The NC memory directory and file name handled on this screen is as follows.

Furthermore, when storing the NC memory file in a device other than the NC memory, be careful not to change the file extension (.XXX).

Data type	NC memory directory path	File name
Machining program	/PRG/USER	(Program No.)
Fixed cycle program	/PRG/FIX	(Program No.)

4.4.11 Edit Lock B and C

This function prohibits editing, erasing, etc. of the machining programs B and C, and protects the machining programs stored in the NC memory.

Machining program	Edit Lock B	Edit Lock C
A 1 to 7999 10000 to 99999999	---	---
B(user standard program) 8000 to 8999	Editing prohibited	---
C(machine tool builder custom) 9000 to 9999	Editing prohibited	Editing prohibited

The operations below in the Edit MDI and the Input/Output screens are influenced by the edit lock setting.

An error will occur if operations that are not possible are attempted.

When the edit lock is valid, processing is executed (except the edit lock target program) by the input/output function.

○ : Operation possible × : Operation not possible

Screen	Operation	Edit lock B			Edit lock C		
		Machining program			Machining program		
		A	B	C	A	B	C
Edit	Search	○	○	×	○	○	×
	Edit	○	×	×	○	○	×
	MDI registration	○	×	×	○	○	×
Edit(Input/Output)	Transfer	○	×	×	○	○	×
	Compare	○	×	×	○	○	×
	Copy	○	×	×	○	○	×
	Merge	○	×	×	○	○	×
	Rename	○	×	×	○	○	×
	Erase	○	×	×	○	○	×
Operation	Buffer correction	○	×	×	○	○	×

(Note 1) When multiple serial files or a wildcard (*) is designated for input/output function, programs except subject to edit lock will be processed.

(Note 2) When a multiple programs are input to the memory without designating the file name like serial input or program batch input, the message "Edit lock B" or "Edit lock C" will be displayed and the input will be interrupted if the program which is subject to edit lock is detected.

4.4.12 Program Display Lock C

This function prohibits display and search for machining program C (machine tool builder custom program).

The following influences are received on each screen according to parameter "#1122 pglk_c".

Influences of program display lock parameter on operation screen

Screen operation	#1122 pglk_c	
	1 (Display: ○ Search: ×)	2 (Display: × Search: ×)
Buffer display of operating program		
Display when [Program display] highlights on 2D check full-screen	The program contents are not displayed. Only "%" is displayed.	
When the menu [Edit] was pressed	The operation message "Program display lock C" appears. The window is opened.	
When the main menu [P corr] was pressed	(When the edit lock B or C is valid, edit lock B or C is given to priority.)	
Search from the operation search window	The search can be executed.	The search cannot be executed. The operation message "Program display lock C" appears. The window is not closed. The contents of input area are not cleared.
Search from the restart search window		
Search from the top search window (of restart search)		

Influences of program display lock parameter on operation screen

Screen operation	#1122 pglk_c	
	1 (Display: ○ Search: ×)	2 (Display: × Search: ×)
The file is automatically opened when changing the edit screen (Note 1)	The program contents are not displayed. Only "%" is displayed.	-(It is not possible to search, so the file is never automatically opened when changing the edit screen.)
When the file is opened by the menu [Open].	The operation message "Program display lock C" appears. The window is not closed. (When the edit lock B or C is valid, edit lock B or C is given to priority.)	
When the main menu [P corr] was pressed		
Right side program display when check main menu is selected	The program contents are not displayed. Only "%" is displayed.	
Search from the operation search window of 2D check	The search can be executed.	The search cannot be executed. The operation message "Program display lock C" appears. The window is not closed.

(Note 1) When changing the edit screen, the file opened immediately before or operation searched/check searched is automatically opened.

4.4.13 Data Protect Keys

The data protect keys can be used to prohibit data setting and erasure. The following three keys are available. (Their names differ according to the machine tool builder. For further details, refer to the instruction manual issued by the machine tool builder.)

- (1) KEY1: Provides general protection for tool data and protection of the coordinate system preset using the origin set.
- (2) KEY2: Protects user parameters and common variables.
- (3) KEY3: Protects the machining program.

Data settings and deletion is stopped if any of the data protection keys is OFF.

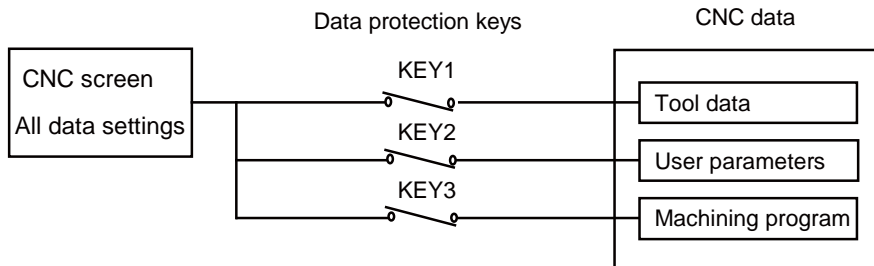

Machining program protection (KEY3)

When the KEY3 is OFF, the following operations are stopped.

No.	Operation details	Screen
1	MDI data memory registration	Edit
2	Machining program editing	Edit
3	New machining program creation	Edit
4	Comment setting for programs being registered	Edit
5	Machining program registration to memory, verification, input/output	Edit
6	Machining program deletion (1 program, all)	Edit
7	Comment setting for programs being registered	Edit
8	Machining program copy, file name change, merge	Edit
9	Machining program buffer correction	Operation

(Note 1) If editing or settings, etc. are performed on the screens shown above when KEY3 is OFF, a "Data protect" message appears.

4.4.14 The Batch Input/Output the Machining Program of NC Memory

One file which consists of two or more machining program can be transferred to NC memory by dividing the file. The machining programs united with one file can be transferred to the external device. The targets are the machining programs of the user.

Batch input and verify to NC memory

Example of "the external device -> NC memory" of machining program batch transfer

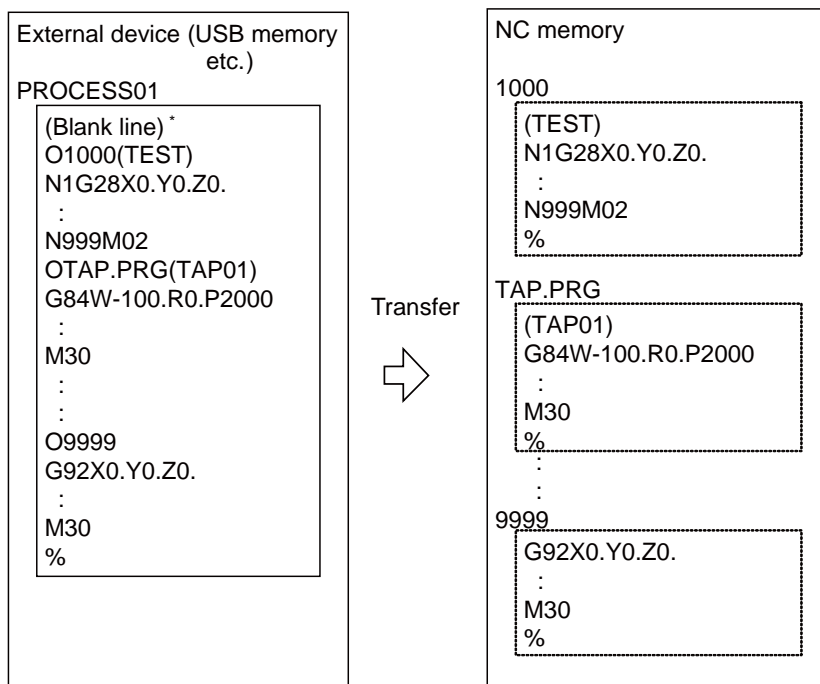

When the external device is serial, the top line is %.

When the transfer direction file name is designated, the top program name of transfer source can be omitted. ("O1000" can be omitted in above example.)

- (1) Use the [←] or [| ←] key to select file setting column A.
- (2) Designate the transfer source device and directory. ➡ The designated device and directory appear.
- (3) Designate the file which consists of two or more machining programs. ➡ The designated file name appears.
- (4) Use the [→] or [→ |] key to select file setting column B.
- (5) Designate the transfer direction device (memory). ➡ The designated device name (memory) appears.
- (6) Press the menu [Program all] . ➡ The "Program all" appears in the directory.
 When the file name is designated, only the top program of transfer source is stored in the designated file. For example of "Example of "the external device -> NC memory" of machining program batch transfer", when "TESTCUT" is designated as the transfer direction file name, the top program is transferred as not "1000" but "TESTCUT".
- (7) Press the menu [Transfr A → B] after press the menu Return or  key. ➡ The operation message "OK? (Y/N)" appears.
- (8) Press the [Y] or [INPUT] key. ➡ Transmission of machining data starts. Transmitting data is displayed in input data display column. The operation message "Transfer complete" appears upon the completion of transmission.
 When the same machining program already exists in transfer direction device, the operation message "Overwrite this file?(Y/N)" appears. The transferring the following program is continued by selecting [Y] or [N] key.
- (9) Press the menu [Compare A:B] key. ➡ The verification of the file starts. The verifying data is displayed. When the verification is completed, the message appears. When the verification error occurs, the error block is displayed in verification data display column and the operation message "Compare error. Compare next file?(Y/N)" appears.

- (Note 1) When programs are input in a batch to NC memory, always specify "Program batch" to NC memory directory as transfer direction. If "Program batch" is not specified, one file is transferred (No batch).
- (Note 2) When the program which is subject to edit lock exists in transfer source, the message "Edit lock B" or "Edit lock C" appears, and transfer is interrupted. When the program which is not subject to edit lock is transferred, delete the program which is subject to edit lock in transfer source. (Refer to "4.5.11 Edit Lock B and C".)
- (Note 3) When the machining program protection is valid (KEY3 is OFF), the program cannot be transferred/verified. (Refer to "4.5.13 Data Protect Keys".)
- (Note 4) The program during automatic operation, program restart or program checking cannot be overwritten. the operation message "Executing automatic operation", "Program restarting" or "Program checking" appears, and transfer is interrupted.
- (Note 5) If the transfer destination includes the file being edited in the custom screen, the operation message "Can't write into being edited file" appears and the transfer may be interrupted.

(Note 6) The first line of the transfer source file is ignored.

(Note 7) When the transfer source is serial, the file is similarly transferred even if the transfer direction setting is the following case 1 and case 2.

	Case 1	Case 2
Device name	Memory	Memory
Directory	Program batch	Program
File name	(Null or file designation)	(Null or file designation)

Batch output and verify from NC memory

Example of "NC memory -> the external device" of machining program batch transfer

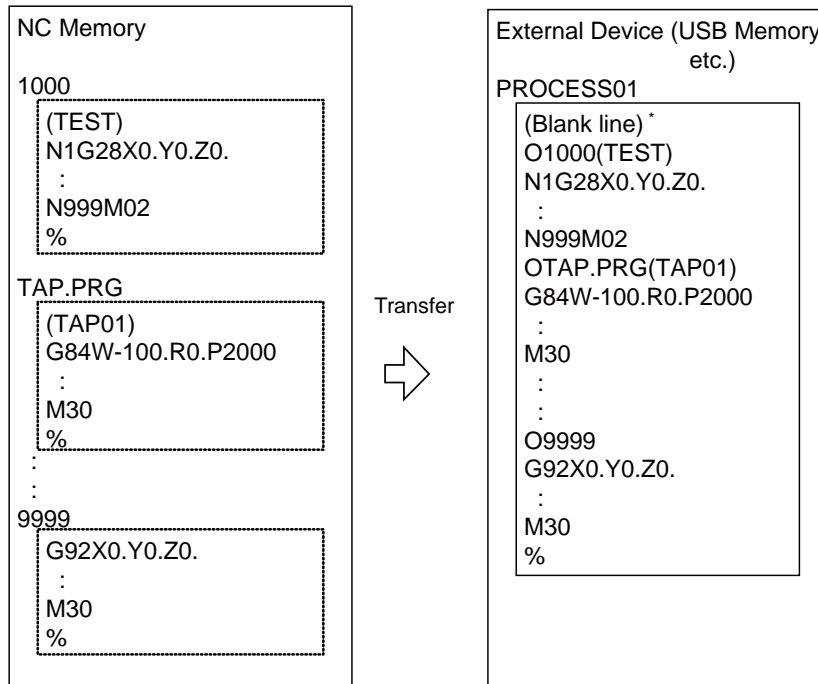

When the external device is serial, the top line is %.

- (1) Use the [←] or [← |] key to select file setting column A.

- (2) Designate the transfer source device (memory). ➡ The designated device (memory) appears.

- (3) Press the menu [Program all] . ➡ The "Program all" appears in the directory.
Do not specify the file name. If the name is specified, an error will occur.

- (4) Use the [→] or [→ |] key to select file setting column B.

- (5) Designate the transfer direction device and directory. ➡ The designated device name and directory appear.

- (6) Designate the transfer direction file to input multiple machining programs. ➡ The designated file name appears.
When the file name is not designated, output to the file "ALL.PRG" of the designated directory.

- (7) Press the menu [Transfr A → B] . ➡ The operation message "OK? (Y/N)" appears.

Transmission of machining data starts.

- (8) Press the [Y] or [INPUT] key. ➡ Transmitting data is displayed in input data display column.
The operation message "Transfer complete" appears upon the completion of transmission.

When the same machining program already exists in transfer direction device, the operation message "Overwrite this file?(Y/N)" appears. The transferring the following program is continued by selecting [Y] or [N] key.

- (9) Press the menu [Compare A:B] key. ➡ The verification of the file starts. The verifying data is displayed. When the verification is completed, the message appears. When the verification error occurs, the error block is displayed in verification data display column and the operation message "Compare error. Compare next file?(Y/N)" appears.

- (Note 1) When programs are output in a batch from NC memory, always specify "Program batch" to NC memory directory as transfer source. If "Program batch" is not specified, the program is transferred by one program per one file.
- (Note 2) When the programs which are subject to edit lock exists in NC memory, those file is not transferred. (The files are transferred excluding those files.) The verification is executed excluding the programs which are subject to edit lock. (Refer to "4.5.11 Edit Lock B and C".)
- (Note 3) When the machining program protection is valid (KEY3 is OFF), the program cannot be transferred/verified. (Refer to "4.5.13 Data Protect Keys".)
- (Note 4) When the transfer direction is serial, the program is similarly transferred even if source of following case 1 and case 2 is set.

	Case 1	Case 2
Device name	Memory	Memory
Directory	Program batch	Program
File name	(Null)	* (Wild card)

Notes

- (1) When the machining program batch input/output function of NC memory is used, "(" cannot be used for the machining program name. It is recognized that the inside of ")" is a comment.
- (2) The file name of file which consists of two or more machining program can have up to 32 characters, including the extension as well as the machining program.
- (3) When the "Program batch" is designated to NC memory directory, it is not possible to delete, rename and merge files. When the files are deleted in a batch, use "Program" for directory, and a wild card (*) for file name.
- (4) Refer to Note of "4.5.3 Transferring a File" for other notes.

4.4.15 Leading Zero

When creating a new machining program

When "#8936 Delete leading 0" is set to "1", if a file name consisting only of numerical figures is input, the file is created with "0" at the head of the file name deleted.

However, if the file name is out of the range between 1 and 99999999, the leading "0" is not deleted. This also applies to MTB macros.

In the case of fixed cycles, regardless of the setting of "#8936 Delete leading 0", a file name to create must be 9 digits, and it must not start from "0". Attempting to create a name not following the conditions above will cause an error.

When "#8936 Delete leading 0" is set to "1", if a file name consisting only of numerical figures is input, the leading "0" is deleted when checking whether the file exists or not, and when checking edit lock B/edit lock C.

(Example) For a directory that has a file "1", if a file name "0001" is attempted to be input as a new file, an error will occur.

Example of deleting of leading zero

Input file name	Created file name	Note
0012345678	12345678	The leading "0"s are deleted
0123456789	0123456789	As this name is out of the range between 1 and 99999999, the leading "0" is not deleted
0123A	0123A	As a nonnumerical character (alphabet) is included, the leading "0" is not deleted
0123.PRG	0123.PRG	As a nonnumerical character (extension) is included, the leading "0" is not deleted

When transferring, or comparing files

In a file transfer with "#8936 Delete leading 0" set to "1", only when the file name of the transfer destination consists only of numerical figures, the leading "0" is deleted when the file is transferred.

However, if the file name is out of the range between 1 and 99999999, the leading "0" is not deleted. This also applies to MTB macros.

In the case of fixed cycles, regardless of the setting of "#8936 Delete leading 0", the name of the file to transfer must be 9 digits, and it must not start from "0". Attempting to create new file whose name does not satisfy the conditions above will cause an error.

In a file comparison, even if "#8936 Delete leading 0" is set to "1", when comparing one separate file that contains one program, "0" at the head of the program name is not deleted. Designating the file name is required.

However, in the case of serial/batch file, comparison is carried out with "0" at the head of the program name deleted.

(Example 1) One file has one program

- (1) The file is transferred from the Memory card to memory.

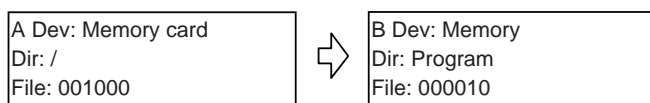

When transferring to the memory, the following occurs.

The leading zero is deleted from the file name.

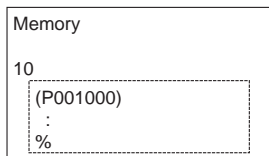

- (2) In order to carry out comparison, change the file name of the transfer destination to "10".
(In a comparison of one separate file that has one program, as "0" at the head of the program name is not deleted, if the file name remains "000010", it will be compared with the file "000010" of the transfer destination.)

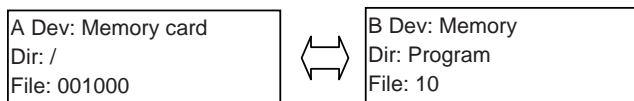

(Example 2) Serial/Batch file

(1) The serial of the transfer destination has files as below.

```

Serial
-----
%
O0000(P0000)
:
O001000(P001000)
:
O001001(P001001)
:
O001000.PRG(P001000.PRG)
:
O001001.PRG(P001001.PRG)
:
O0123456789(P0123456789)
:
%
    
```

(2) The files are transferred from the serial to memory.

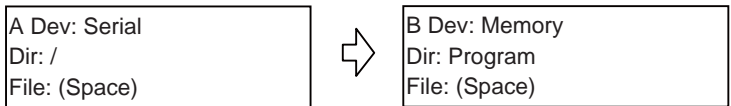

The files are transferred to the memory as follows.

- Files whose leading zeros are deleted: 001000, 001001
- Files whose leading zeros are not deleted as the names are out of the range between 1 and 99999999: 0000, 0123456789
- Files whose leading zeros are not deleted as the names contain nonnumerical characters: 001000.PRG, 001001.PRG

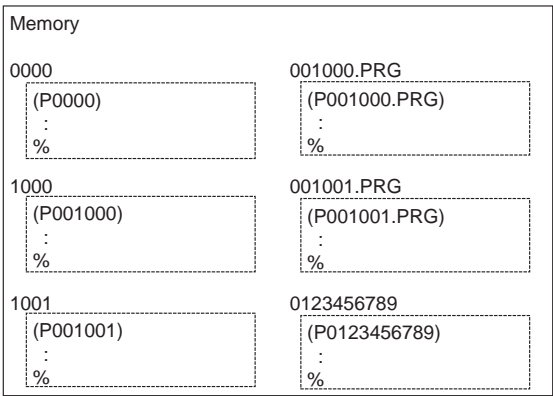

(3) Comparison is carried out. (As the serial/batch files are compared with the leading zeros deleted, changing file names is not required.)

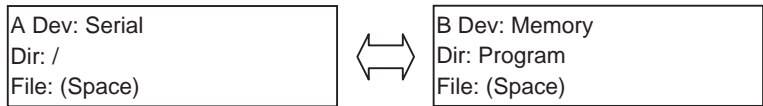

Diagnosis Screens

5.1 System Configuration Screen

The hardware configuration (card name and sub-number), software configuration (software number and sub-number), and PLC program configuration (file name, file label, and execution type) are displayed in this screen.

■ Software configuration

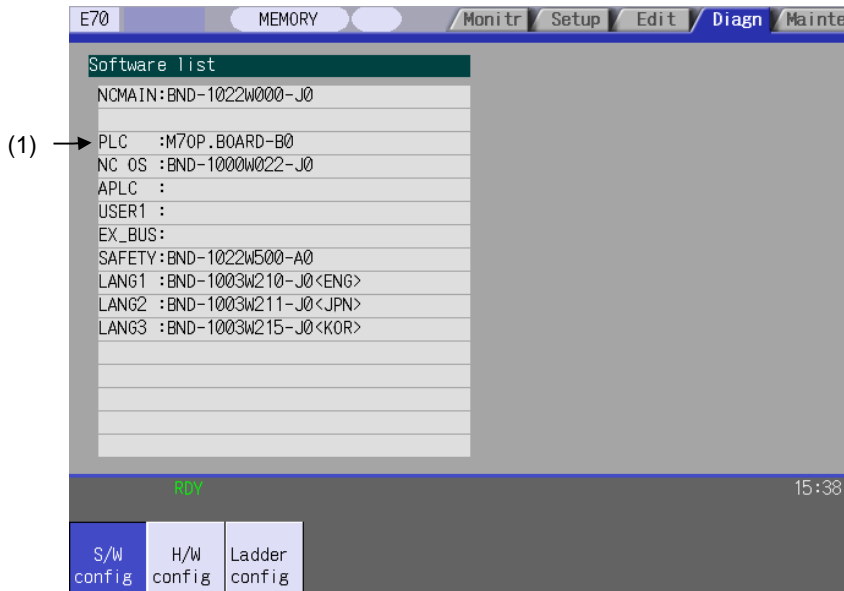

■ Hardware configuration

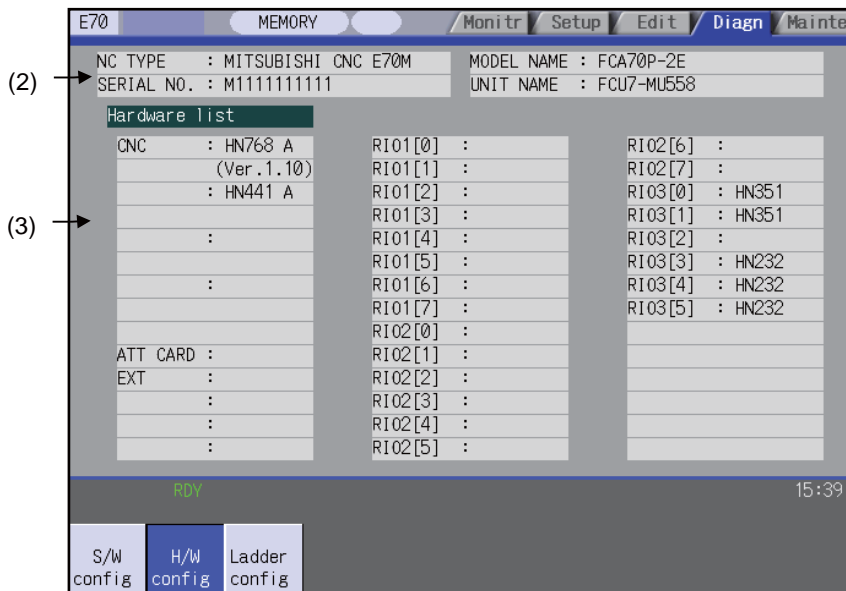

■ PLC program configuration

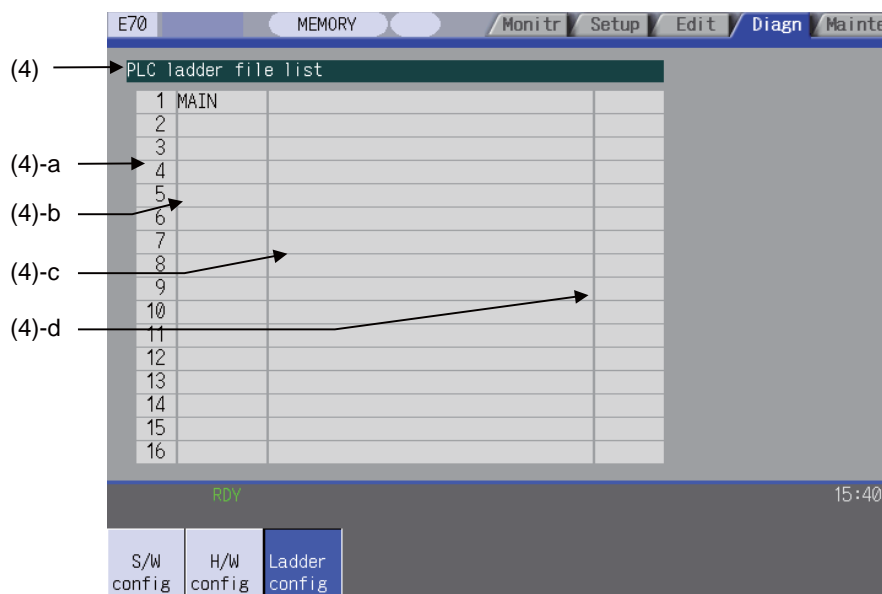

Display items

Display item		Details	
(1)	Software list	This displays a list of the software being used.	
(2)	NC serial No.	This displays the NC model name, serial No, system type, and unit type.	
		NC TYPE : MITSUBISHI CNC E70*	NC type
		MODEL NAME : FCA70* -**	System type name
		SERIAL NO. : M7123456789	Serial No.
	UNIT NAME : FCU7-MU558	Unit type	
(3)	Hardware list	This displays each hardware name.	
	E70 Series	CNC :HN768 :HN793 :HN441	Main CPU Front memory interface card Memory card
		RIO1[n] : RIO2[n] : RIO3[n] :	Remote IO unit 1 (n= 0 to 7) Remote IO unit 2 (n= 0 to 7) Remote IO unit 3 (n= 0 to 7) There are up to three channels. The 7th and 8th station of the RIO3 channel is fixed for use with the handle I/F and is not displayed.

Display item		Details	
(4)	PLC ladder file list	This displays the file name, file label, execution type for each PLC ladder program. Use <input type="button" value="↑"/> / <input type="button" value="↓"/> keys to change the pages and refer it.	
		(a) Registration No.	This displays the registration No. of each PLC program file. Registration size is max. 32 files. The target file to be executed is max. 20 files.
		(b) File name	This displays the file name of PLC program file. (data of GX Developer) Max. 8 characters.
		(c) File label	This displays this file label of PLC program file. (data of GX Developer) Max. 32 characters.
		(d) Execution type	This displays the execution type of PLC program. HIGH:High-speed PLC program MIDDLE:Middle-speed PLC program INTIAL:Initial state of PLC program WAIT:Standby PLC program LOW:Low-speed PLC program (blank):Not the target of the execution.

Menus

Menu	Details	Type	Reference
<input type="button" value="S/W config"/>	This displays the software list.	B	
<input type="button" value="H/W config"/>	This displays the hardware list.	B	
<input type="button" value="Ladder config"/>	This displays the PLC program list (file name, file label, and execution type)	B	

5.2 Option Display Screen

There is no software option available for E70 series.

5.3 I/F Diagnosis Screen

The various input/output signals for the PLC (Programmable Logic Controller) control can be displayed and set in this screen.

These signals can be used in confirmation of the machine sequence operation during PLC development, and in confirmation and forced output, etc., of the input/output data between the NC and PLC.

(Note) Pay close attention to the sequence operation when using these functions during machine operation.

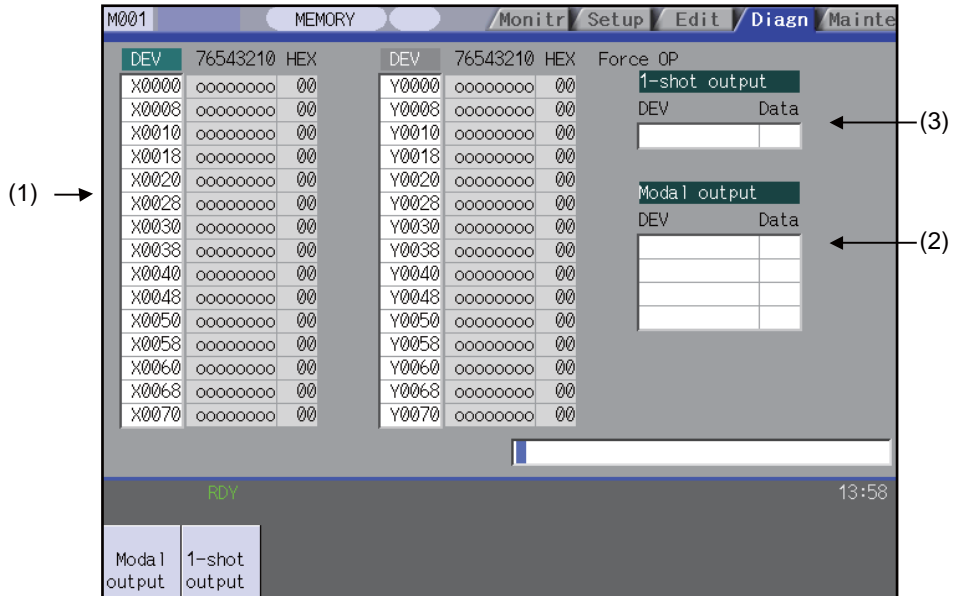

Display items

Display item	Details
(1) Device No. and input/output signal value (binary/ hexadecimal display)	This displays the data from the device Nos. designated in the setting area in numerical order. The data is displayed as binary (bit units) and hexadecimal values. Individual device Nos. can be displayed separately in the left area and right area. Select the valid area with the key when operations such as display changeover and data setting are carried out. Each X, Y, M, F, L, SM, TI, TO, TS, TA, STI, STO, STS, STA, CI, CO, CS, CA, D, R, SB, B, V, SW, SD, W, P, K, and H data is the target data.
(2) Modal output	This displays the data and device to carry out modal output. The details to be defined are set here when carrying out the modal type forced output of PLC interface signals. Refer to "5.3.2 Carrying Out Modal Output" for details.
(3) 1-shot output	This displays the data and device to carry out one-shot output. The details to be defined are set here when carrying out the one-shot type forced output of PLC interface signals. Refer to "5.3.3 Carrying Out One-shot Output" for details.

Menus

Menu	Details	Type	Reference
	This changes the setting area to an input standby status. The signal is forcibly output (modal).	A	5.3.2 Carrying out modal output
	This changes the setting area to an input standby status. The signal is forcibly output (one-shot).	A	5.3.3 Carrying out one-shot output

How to read the device No. and display data

A device is an address for classifying a signal handled in the PLC. A device No. is a series of numbers attached to that device.

Device No. (bit-type)

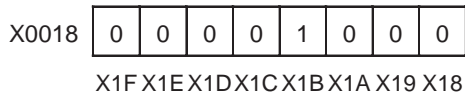
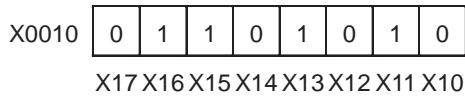

DEV	76543210	HEX	DEV	76543210	HEX
X0000	00000000	00	Y0000	00000000	00
X0008	10100001	A1	Y0008	00000000	00
X0010	01101010	6A	Y0010	10100000	A0
X0018	00001000	08	Y0018	00000001	01
X0020	01111100	7C	Y0020	00000000	00
X0028	00001111	0F	Y0028	00000000	00
X0030	00000010	02	Y0030	00000000	00

Signal status display corresponding to each device No. (I/O)

Device No. (word-type)

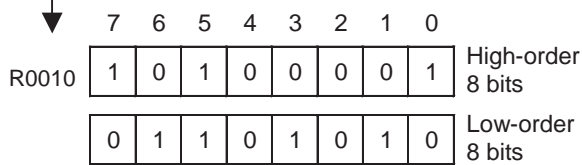

DEV	76543210	HEX
R00010	10100001	A1
	01101010	6A
R00011	00001001	09
	00000101	05
R00012	00010010	12
	00000110	06
R00013	00001010	0A
	00010101	15

List of devices for PLC uses

Device	Device No.	No. of points	Units	Details
X(*)	X0 to X1FFF	8192	1-bit	Input signals to the PLC. Machine input, etc.
Y	Y0 to Y1FFF	8192	1-bit	Output signals to the PLC. Machine output, etc.
M	M0 to M10239	10240	1-bit	For temporary memory
F	F0 to F1023	1024	1-bit	For temporary memory. Alarm message interface.
L	L0 to L511	512	1-bit	Latch relay (Backup memory)
SM(*)	SM0 to SM127	128	1-bit	Special relay
TI	TI0 to TI703	704	1-bit	Timer contact
TO	TO0 to TO703	704	1-bit	Timer output
TS	TS0 to TS703	704	16-bit	Timer setting value
TA	TA0 to TA703	704	16-bit	Timer current value
STI	STI0 to STI63	64	1-bit	Integrated timer contact
STO	STO0 to STO63	64	1-bit	Integrated timer output
STS	STS0 to STS63	64	16-bit	Integrated timer setting value
STA	STA0 to STA63	64	16-bit	Integrated timer current value
CI	CI0 to CI255	256	1-bit	Counter contact
CO	CO0 to CO255	256	1-bit	Counter output
CS	CS0 to CS255	256	16-bit	Counter setting value
CA	CA0 to CA255	256	16-bit	Counter current value
D	D0 to D2047	2048	16-bit	Data register
R(*)	R0 to R13311	13312	16-bit	File register
SB	SB0 to SB1FF	512	1-bit	MELSEC NET/10 link special relay
B	B0 to B1FFF	8192	1-bit	MELSEC NET/10 link relay
V	V0 to V255	256	1-bit	MELSEC NET/10 edge relay
SW	SW0 to SW1FF	512	16-bit	MELSEC NET/10 link special register
SD	SD0 to SD127	128	16-bit	MELSEC NET/10 special register
W	W0 to W1FFF	8192	16-bit	MELSEC NET/10 link register

(Note) The use of devices marked with a * mark in the device column has been determined. Do not use devices other than those corresponding to the input/output signals with the machine side (input/output signals of the remote I/O unit), even if it is an undefined vacant device.

5.3.1 Displaying the PLC Device Data



The various status signals and register data used in the PLC can be monitored and displayed.

When this screen is first selected, the respective 16-byte amounts of input/output data are displayed from device "X0000" on the left display area, and from device "Y0000" on the right side.

This screen constantly monitors and displays the PLC signal statuses. Consequently, when signals are changed in the PLC, the display is changed according to the changes.

Note that because time differences occur between the PLC signal change and the signal display, there may be a delay in the display. The machine may also not be able to correspond to extremely brief signal changes.

Displaying the data of a arbitrary device No. "X0020"

- (1) Press the menu tab key  /  , and select the area to display the data.
- (2) Set the device No. (X0020), and press the [INPUT] key.



The device "X0020" appears at the head of the valid display area.

DEV	76543210	HEX	DEV	76543210	HEX
X0020	11111111	FF	Y0000	00000000	00
X0028	01000000	40	Y0008	00000001	01
X0030	00001110	0E	Y0010	00000000	00
X0038	00000000	00	Y0018	00000000	00

(Note) When setting the device No., an error will occur if a number exceeding the specifications or an illegal address is set.

Changing the display with the page keys

The valid area device Nos. change in page units when  /  is pressed. Changing of the pages stops within the range of device numbers of which the device has.

- (1) Press the  key.



The data is displayed from the next number currently displayed.

DEV	76543210	HEX	DEV	76543210	HEX
X0000	10000001	81	Y0000	00000000	00
X0008	00000010	02	Y0008	00000001	01
X0010	00001111	0F	Y0010	00000000	00
X0018	10011111	9F	Y0018	00000000	00



DEV	76543210	HEX	DEV	76543210	HEX
X0080	11111111	FF	Y0000	00000000	00
X0088	01000000	40	Y0008	00000001	01
X0090	00001111	0F	Y0010	00000000	00
X0098	00000000	00	Y0018	00000000	00



5.3.2 Carrying Out Modal Output

Modal type forced output of PLC interface signals is carried out. Once set, this data is held until cancelled, the power is turned ON/OFF, or other data is overwritten. There are four sets of devices that modally output. If this number is exceeded, the previously existing data is overwritten.

Menus used in modal output

Menu	Details	Type	Reference
Modal clear	This releases the modal output for the device at the cursor position in the modal output area. The released data is erased from this area.	C	"Releasing the modal output"



Modally outputting data "1" to device "X0048"

- (1) Press the menu key [Modal output] .  The modal output mode is entered, and the cursor appears at the modal output area.
- (2) Using the [↑] and [↓] keys, move the cursor to the setting position.
- (3) Set the device and data, and press the [INPUT] key. X0048/1 [INPUT]  Modal output is executed, and the cursor disappears. The data that was in the cursor position is overwritten by the input data, and is invalidated. The modal output mode is cancelled by pressing the  key.

(Note 1) The data of the modally output device is displayed in order in the selected area.
This modal output is held until the output is cancelled or the power is turned OFF.

(Note 2) When no data is set (Ex. "X0048/", "X0048"), the operation message "Setting Data not found" is displayed.

Releasing the modal output

- (1) Press the menu key [Modal output] .  The modal output mode is entered, and the cursor appears at the modal output area.
- (2) Using the [↑] and [↓] keys, move the cursor to the data to be released.
- (3) Press the menu key [Modal clear] .  The data that was in the cursor position is released from modal output. The "DEV" and "Data" columns become blank. The modal output mode is cancelled by pressing the  key.

CAUTION

 Pay close attention to the sequence operation when carrying out forced data setting (forced output) in the I/F diagnosis screen during machine operation.

5.3.3 Carrying Out One-shot Output

The one-shot type PLC interface signal forced output is forcibly output only once during the screen operations. Thus, it may not be possible to confirm the PLC interface signals updated with the PLC on the screen.

One-shot outputting data "1" to device "X0042"

- | | | |
|--|---|---|
| (1) Press the menu key [1-shot output]. | ➔ | The one-shot output mode is entered, and the cursor appears at the one-shot output area. |
| (2) Set the device and data, press the [INPUT] key.
X0042/1 [INPUT] | ➔ | The input data is overwritten in the one-shot output area, and is one-shot output. The cursor in the one-shot output area disappears. The data of the one-shot output device is displayed in order in the selected area. The one-shot output mode is cancelled by pressing the  key. |

(Note 1) Because the input signal (X, etc.) to the PLC is updated at the head of each PLC cycle, the machine immediately returns to the normal state, even if one-shot type forced output is carried out.

(Note 2) When no data is set (Ex.: "X0048/", "X0048"), the operation message "Setting Data not found" is displayed.

CAUTION

 Pay close attention to the sequence operation when carrying out forced data setting (forced output) in the I/F diagnosis screen during mach

5.4 Drive Monitor Screen

The diagnosis information from the drive section can be monitored with this screen. Servo axis unit, spindle unit, power supply unit and synchronous error information is displayed.

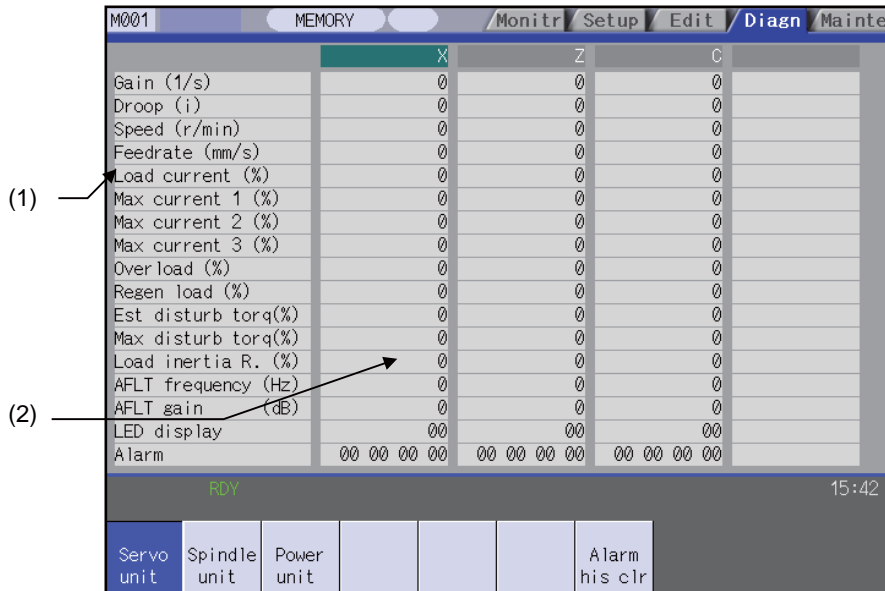

Display items



Display item	Details
(1) Monitoring items	This displays each item being monitored. The display is changed using the page changeover keys.
(2) Data of each axis and unit	This displays the data of each axis or each unit being monitored.

Menus

Menu	Details	Type	Reference
Servo unit	This displays the diagnosis information of the servo unit in the data display area.	B	5.4.1 Servo axis unit display items
Spindle unit	This displays the diagnosis information of the spindle unit in the data display area.	B	5.4.2 Spindle unit display items
Power unit	This displays the diagnosis information of the in the data display area.	B	5.4.3 Display items for the power supply unit
Alarm his clr	This clears the diagnosis information alarm history.	A	5.4.6 Clearing the alarm history
Next Ax	This displays the data for the next four axes. The menu appears and operation is possible only when diagnosis information for five or more axes is displayed.	C	

5.4.1 Servo Axis Unit Display Items

The various data related to the servo axis (NC axis, PLC axis) is monitored.

To reference, change the display items using the  key and  key.

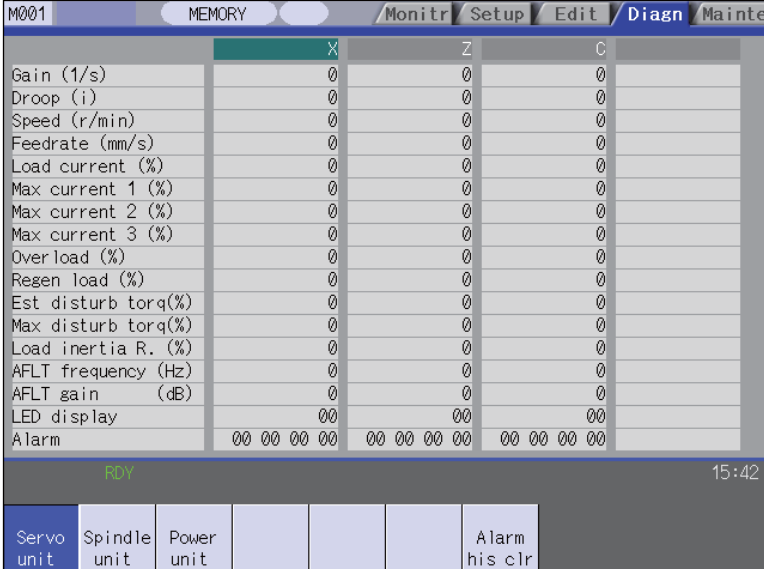

	X	Z	C
Gain (1/s)	0	0	0
Droop (i)	0	0	0
Speed (r/min)	0	0	0
Feedrate (mm/s)	0	0	0
Load current (%)	0	0	0
Max current 1 (%)	0	0	0
Max current 2 (%)	0	0	0
Max current 3 (%)	0	0	0
Overload (%)	0	0	0
Regen load (%)	0	0	0
Est disturb torq(%)	0	0	0
Max disturb torq(%)	0	0	0
Load inertia R. (%)	0	0	0
AFLT frequency (Hz)	0	0	0
AFLT gain (dB)	0	0	0
LED display	00	00	00
Alarm	00 00 00 00	00 00 00 00	00 00 00 00

RDY 15:42

Servo unit Spindle unit Power unit Alarm his clr

The axis name set in the base axis specification parameter "#1022 axname2" appears at the axis name.

Display items

Display item	Details
Gain (1/s)	This displays the position loop gain. Position loop gain : $\frac{\text{Feedrate (mm/s)}}{\text{Tracking delay error (mm)}}$
Droop (i)	The error of the actual machine position to the command position is called droop. This error is proportional to command speed value.
Speed (r/min)	This displays the actual rotation speed of motor.
Feedrate (mm/s)	This displays the feedrate detected by the detector mounted on the machine end.
Load current (%)	This displays the FB value of the motor current in terms of continuous current during stalling.
Max current 1 (%)	This displays the motor current command in terms of continuous current during stalling. An absolute value of the current command peak value sampled after the power ON is displayed.
Max current 2 (%)	This displays the motor current command in terms of continuous current during stalling. An absolute value of the current command peak value sampled in most recent 2 seconds is displayed.
Max current 3 (%)	This displays the FB value of the motor current in terms of continuous current during stalling. An absolute value of the current FB peak value sampled in most recent 2 seconds is displayed.
Overload (%)	This is the data used to monitor the motor overload.
Regen Load (%)	This is the data used to monitor the resistance overload state when the resistance regenerative power supply is connected.
Est disturb torq (%)	This displays the estimated disturbance torque in terms of stall rated torque when the disturbance observer is valid.
Max disturb torq (%)	This displays the estimated disturbance torque in terms of stall rated torque when the collision detection function is adjusted. An absolute value of the estimated disturbance torque peak value sampled in most recent 2 seconds is displayed.
Load inertia R. (%)	This displays the estimated load inertia ratio when the collision detection function is adjusted.
AFLT frequency (Hz)	This displays the present operation frequency of the adaptive filter.

Display item	Details
AFLT gain (dB)	This displays the present filter depth of the adaptive filter.
LED display	This displays the 7-segment LED of the driver.
Alarm	This displays the alarms and warnings other than the LED display (displayed on drive unit side).
Cycle counter (p)	This displays the position within one rotation of the encoder detector. The position is displayed as a grid point value as "0", within one rotation in the range of "0" to "RNG (movement units) × 1000".
Grid space	This displays the grid space for the reference position return. (Command unit)
Grid amnt	This displays the distance from the dog-off point to the grid point when the dog-type reference position return is displayed. The grid mask amount is not included. (Command unit)
Machine posn	This displays the NC basic machine coordinate system position. (Command unit)
Motor end FB	This displays the feedback value of the speed detector. (Command unit)
Machine end FB	This displays the feedback position of the machine end position detector. (Command unit)
FB error (i)	This displays the error of the motor end FB and machine end FB.
DFB compen amnt (i)	This displays the compensation pulse amount during dual feedback control.
Remain command	The remaining movement distance of one block is displayed. (Command unit)
Currnt posn (2)	The value of the tool compensation amount subtracted from the current position is displayed. (Command unit)
Man int amt	The amount of interrupt movement in the manual absolute OFF state is displayed. (Command unit)
Abs pos command	This displays the coordinates of absolute position excluding the machine error compensation amount. (Command unit)
AUX current sta No. (Note)	This displays the current station No.
AUX current posn (Note)	This displays the current coordinates position.
AUX inst station No. (Note)	This displays the command station No. of automatic operation or the nearest station No. to stop by manual operation etc.
AUX inst posn (Note)	This displays the coordinates position corresponding to target station No.
Mach err comp val	This displays the machine error compensation amount. (Command unit)

(Note) The data only for the PLC axis indexing function. "-" is displayed in the usual axis (NC axis or during PLC axis control) not used by the PLC axis indexing function.

Display item	Details
Control input 1L 1H : 6L 6H	This indicates the control signal input from NC. This is used by the system.
Control output 1L 1H : 6L 6H	This indicates the control signal output to NC. This is used by the system.
Detection system	This displays the detector type symbol of the absolute position detection system. ES:Semi-closed encoder EC:Ball screw end encoder LS:Linear scale MP:MP scale ESS:Semi-closed high-speed serial encoder ECS:Ball screw end high-speed serial encoder INC:Incremental
Power OFF posn	This displays the coordinate at NC power OFF in the basic machine coordinate system. (Command unit)
Power ON posn	This displays the coordinate at NC power ON in the basic machine coordinate system. (Command unit)
Current posn	This displays the current coordinate in the basic machine coordinate system. (Command unit)
R0	This displays the multi-rotation counter value of the detector stored in the memory during basic point setting.
P0	This displays the position within one rotation of the detector stored in the memory during basic point setting.
E0	This displays the absolute position error stored in the memory during basic point setting.
Rn	This displays the multi-rotation counter value of the current detector.
Pn	This displays the position within one rotation of the detector.
En	This displays the absolute position error during NC power OFF.
ABS0	This displays the absolute position reference counter.
ABSn	This displays the current absolute position.
MPOS	This displays the offset amount of the MP scale when the power is turned ON.
Unit type	This displays the servo driver type.
Unit serial No.	This displays the servo driver serial No.
Software version	This displays the servo side software version.
Control method	SEMI:Semi-closed loop CLOSED:Closed loop DUAL:Dual feedback
Motor end detector	This displays the motor end detector type.
Motor end detect No	This displays the motor end detector serial No.
Machine end detector	This displays the machine end detector type. The type is displayed when the control method is CLOSED or DUAL. * is displayed when the method is SEMI.
Mach. end detect No	This displays the machine end detector serial No.
Motor	This displays the motor type.
Work time	This displays the READY ON work time. (Units: 1hr)
Alarm hist 1:Time 1:Alarm } 8:Time 8:Alarm	This displays servo alarms that occurred in latest order with the following formats. Time:Work time when the alarm occurred. Alarm No.:Number of the servo alarms that occurred.
Maint hist 1 to 4	This displays the maintenance dates. Year:One digit Month:1 to 9, X (Oct.), Y (Nov.), Z (Dec.)
Maint status	This displays the maintenance status.

5.4.2 Spindle Unit Display Items

The various data related to the spindle is monitored.

Change the display items using the  key and  key to refer to the data.

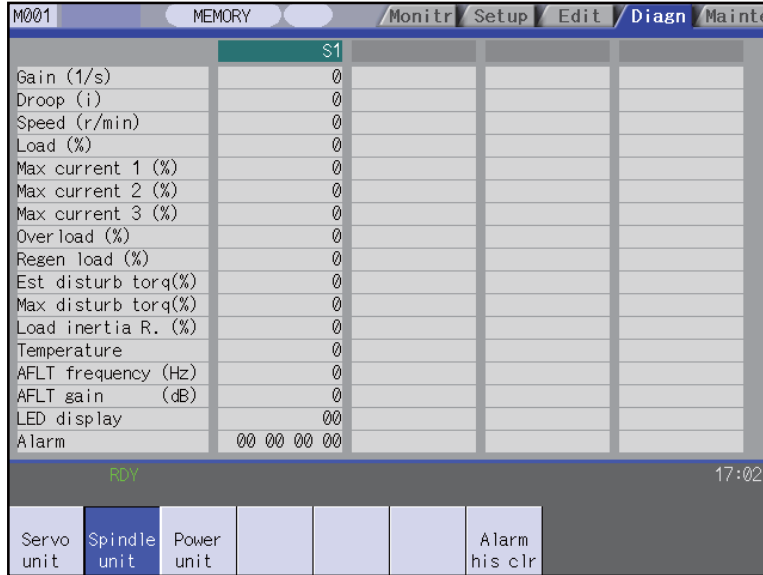

Display items

Display items	Details
Gain(1/s)	This displays the position loop gain. Position loop gain : $\frac{\text{Feedrate (mm/s)}}{\text{Tracking delay error (mm)}}$
Droop(i)	The error of the actual machine position to the command position is called droop. This error is proportional to command speed value.
Speed(r/min)	This displays the actual rotation speed of motor.
Load(%)	This displays the motor load.
Max current 1(%)	This displays the motor current command in terms of continuous current during stalling. An absolute value of the current command peak value sampled after the power ON is displayed.
Max current 2(%)	This displays the motor current command in terms of continuous current during stalling. An absolute value of the current command peak value sampled in most recent 2 seconds is displayed.
Max current 3(%)	This displays the FB value of the motor current in terms of continuous current during stalling. An absolute value of the current FB peak value sampled in most recent 2 seconds is displayed.
Overload(%)	This is the data used to monitor the motor overload.
Regen load(%)	This is the data used to monitor the resistance overload state when the resistance regenerative power supply is connected.
Est disturb torq(%)	This displays the estimated disturbance torque in terms of stall rated torque when the disturbance observer is valid.
Max disturb torq(%)	This displays the estimated disturbance torque in terms of stall rated torque when the collision detection function is adjusted. An absolute value of the estimated disturbance torque peak value sampled in most recent 2 seconds is displayed.
Load inertia R.(%)	This displays the estimated load inertia ratio when the collision detection function is adjusted.
Temperature (° C)	This displays the thermistor temperature.
AFLT frequency(Hz)	This displays the current operation frequency of the adaptive filter.
AFLT gain(dB)	This displays the current filter depth of the adaptive filter.
LED display	This displays the 7-segment LED of the driver.
Alarm	This displays the alarms and warnings other than the LED display.
Cycle counter(p)	This displays the position within one rotation of the encoder detector. The position is displayed within one rotation in the range of "0" to "RNG (movement units) × 1000" using the grid point value as "0".

Display items	Details
Grid space	This displays the grid space for the reference position return. (Command unit)
Grid amnt	This displays the distance from the dog-off point to the grid point when the dog-type reference position return is displayed. The grid mask amount is not included. (Command unit)
Machine posn	This displays the NC basic machine coordinate system position. (Command unit)
Motor end FB	This displays the feedback value of the speed detector. (Command unit)
FB error(i)	This displays the error of the motor end FB and machine end FB.
DFB compen amnt(i)	This displays the compensation pulse amount during dual feedback control.
Sync tap err(mm)	This displays the synchronous error width between the spindle and the drilling axis during the synchronous tapping. (mm) (Note 1) (When the parameter "#1041 I_Inch" is set to "1", "Sync tap err (inch)" is displayed.)
Sync tap err(deg)	This displays the synchronous error angle between the spindle and the drilling axis during the synchronous tapping. (degree) (Note 1)

(Note 1) Synchronous tapping error

This displays the maximum values of the synchronous tapping error that occur during the synchronous tapping. The synchronous tapping error means the motor tracking delay for the commanded positions of the spindle and the tapping axis. The positive synchronous tapping error means that the tapping axis is delayed responding to the spindle, and the negative synchronous tapping error means that the spindle is delayed responding to the tapping axis.

Data name	Details
Synchronous tapping error width (Max value)	- This outputs the data of which absolute value is the largest among the synchronous tapping error width (-99999.999 to 99999.999 mm) during the synchronous tapping modal. - This data will be initialized to "0" when entering the synchronous tapping modal or restoring the power. Other than that, the data continues to display the maximum value.
Synchronous tapping error angle (Max value)	- This outputs the data of which absolute value is the largest among the synchronous tapping error angle (-99999.999 to 99999.999 °) during the synchronous tapping modal. - This data will be initialized to "0" when entering the synchronous tapping modal or restoring the power. Other than that, the data continues to display the maximum value.
Control input 1L	This displays the control input signals from the NC.(bit0 to bit7) Bit0:READY ON command Bit1:Servo ON command Bit7:Alarm reset command
Control input 1H	This displays the control input signals from the NC.(bit8 to bitF) Bit8:Torque limit selection command 1 Bit9:Torque limit selection command 2 BitA:Torque limit selection command 3
Control input 2L	This displays the control input signals from the NC.(bit0 to bit7)
Control input 2H	This displays the control input signals from the NC.(bit8 to bitF) Bit9:Speed observation command valid BitA:Door closed (controller) BitB:Door closed (all drive units)
Control input 3L	This displays the control input signals from the NC.(bit0 to bit7)
Control input 3H	This displays the control input signals from the NC.(bit8 to bitF)
Control input 4L	This displays the control input signals from the NC.(bit0 to bit7) Bit0-2:Spindle control mode selection command 1, 2, 3 Bit5:Gear selection command 1 Bit6:Gear selection command 2
Control input 4H	This displays the control input signals from the NC.(bit8 to bitF) BitC:M-coil switch command BitD:L-coil switch command BitE:Sub-motor selection command
Control input 5L	This displays the control input signals from the NC.(bit0 to bit7)
Control input 5H	This displays the control input signals from the NC.(bit8 to bitF) Bit1:Spindle holding force up
Control input 6L	This displays the control input signals from the NC.(bit0 to bit7)
Control input 6H	This displays the control input signals from the NC.(bit8 to bitF)

Data name	Details
Control output 1L	This displays the control output signals to the NC.(bit0 to bit7) Bit0:In READY ON Bit1:In Servo ON Bit7:In alarm occurrence
Control output 1H	This displays the control output signals to the NC.(bit8 to bitF) Bit8:In torque limit selection 1 Bit9:In torque limit selection 2 BitA:In torque limit selection 3 BitC:In-position BitD:In torque limitation BitF:In warning occurrence
Control output 2L	This displays the control output signals to the NC.(bit0 to bit7) Bit 0:Z-phase passed Bit 3:In zero speed Bit 7:In external emergency stop
Control output 2H	This displays the control output signals to the NC.(bit8 to bitF) Bit 9:In speed observation Bit A:Door closed (controller) Bit B:Door closed (local drive units)
Control output 3L	This displays the control output signals to the NC.(bit0 to bit7)
Control output 3H	This displays the control output signals to the NC.(bit8 to bitF)
Control output 4L	This displays the control output signals to the NC.(bit0 to bit7) Bit0-2:Spindle control mode selected 1, 2, 3 Bit 5:Gear selected 1 Bit 6:Gear selected 2
Control output 4H	This displays the control output signals to the NC.(bit8 to bitF) Bit C:M-coil switched Bit D:L- coil switched Bit E:Sub-motor selected
Control output 5L	This displays the control output signals to the NC.(bit0 to bit7) Bit0:Current detection Bit1:Speed detection Bit6:In coil changeover
Control output 5H	This displays the control output signals to the NC.(bit8 to bitF) Bit8:1-amplifire 2-motor switching Bit9:2nd speed detection BitE:In spindle holding force up BitF:2nd in-position
Control output 6L	This displays the control output signals to the NC.(bit0 to bit7)
Control output 6H	This displays the control output signals to the NC.(bit8 to bitF)
Unit type	This displays the spindle type.
Unit serial No.	This displays the spindle serial No.
Software version	This displays the software No. and version on the spindle side.
Motor end detect No	This displays the motor end detector serial No.
Mach. end detect No	This displays the machine end detector serial No.
Motor	It displays the motor type which is set for the spindle specification parameter "#3138 motor_type". The maximum of 26 words are displayed with 2 lines and left aligned.
Work time	This displays the READY ON cumulative time. (Units: 1hr)
Alarm hist 1:Time 1:Alarm : 8:Time 8:Alarm	This displays servo alarms that occurred in latest order with the following formats. Time:Work time when the alarm occurred. Alarm No.:Number of the servo alarms that occurred.
Maint hist 1 to 4	This displays the maintenance dates. Year:One digit Month:1 to 9, X (Oct.), Y (Nov.), Z (Dec.)
Maint status	This displays the maintenance status.

5.4.3 Display Items for the Power Supply Unit

The various data related to the power supply is monitored.

Change the display items using the  key and  key to refer to the data.

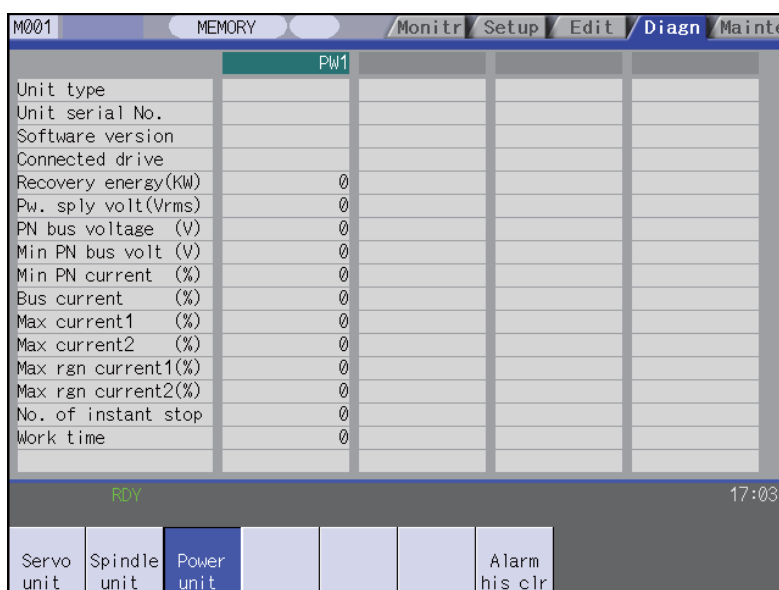



Unit type				
Unit serial No.				
Software version				
Connected drive				
Recovery energy(KW)	0			
Pw. sply volt(Vrms)	0			
PN bus voltage (V)	0			
Min PN bus volt (V)	0			
Min PN current (%)	0			
Bus current (%)	0			
Max current1 (%)	0			
Max current2 (%)	0			
Max rgn current1(%)	0			
Max rgn current2(%)	0			
No. of instant stop	0			
Work time	0			

Display items

Display item	Details
Unit type	This displays the power supply unit type.
Unit serial No.	This displays the serial No. of the power supply unit.
Software version	This displays the software version.
Connected drive	This displays the I/F channel No. (mcp_no, smcp_no) of the drive unit connected to each power supply unit.
Recovery energy(KW)	This displays the regenerative power every two seconds. (0 to 999kW)
Pw. sply volt (Vrms)	This displays the effective value of the power supply voltage. (0 to 999Vrms)
PN bus voltage (V)	This displays PN bus voltage. (0 to 999V)
Min PN bus volt (V)	This displays the minimum PN bus voltage after the NC power ON. (0 to 999V)
Min PN current (%)	This displays the bus current when PN bus voltage is at minimum. (driving: +, regenerative: -) (0 to 999%)
Bus current (%)	This displays the bus current. (driving: +, regenerative: -) (0 to 999%)
Max current1 (%)	This displays the maximum driving current after the NC power ON. (0 to 999%)
Max current2 (%)	This displays the maximum driving current in most recent 2 seconds. (0 to 999%)
Max rgn current1(%)	This displays the maximum regenerative current after the NC power ON. (0 to 999%)
Max rgn current2(%)	This displays the maximum regenerative current in most recent 2 seconds. (0 to 999%)
No. of instant stop	This displays the number of instantaneous stop exceeding 1 cycle of the power. (0 to 9999 times)
Work time	This displays the READY ON cumulative time. (Units: 1hr)
Alarm hist 1:Time 1:Alarm : 8:Time 8:Alarm	This displays servo alarms that occurred in latest order with the following formats. Time:Work time when the alarm occurred Alarm No.:Number of the servo alarms that occurred
Maint hist 1 to 4	This displays the maintenance dates. Year:One digit Month:1 to 9, X (Oct.), Y (Nov.), Z (Dec.)
Maint status	This displays the maintenance status.

5.4.4 Clearing the Alarm History

Operation method

- (1) Press the menu [Servo unit] or [Spindle unit] .
- (2) Using the menu [Next axis] , tab keys  and  , select the axis (device) from which to clear the alarm history.
- (3) Press the menu [Alarm his clr] .

➔ The menu is highlighted, and a message appears to confirm the erasing. The alarm history1: Time appears at the head.

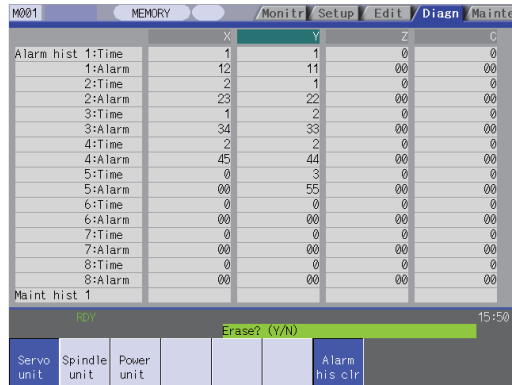

	X	Y	Z	C
Alarm hist 1:Time	1	1	0	0
1:Alarm	12	11	00	00
2:Time	2	1	0	0
2:Alarm	23	22	00	00
3:Time	1	2	0	0
3:Alarm	34	33	00	00
4:Time	2	2	0	0
4:Alarm	45	44	00	00
5:Time	0	3	0	0
5:Alarm	00	55	00	00
6:Time	0	0	0	0
6:Alarm	00	00	00	00
7:Time	0	0	0	0
7:Alarm	00	00	00	00
8:Time	0	0	0	0
8:Alarm	00	00	00	00
Maint hist 1				

Erase? (Y/N)

Servo unit Spindle unit Power unit Alarm his clr

- (4) Press the [Y] key.

➔ The alarm history data for the selected axis (device) is cleared to zero.

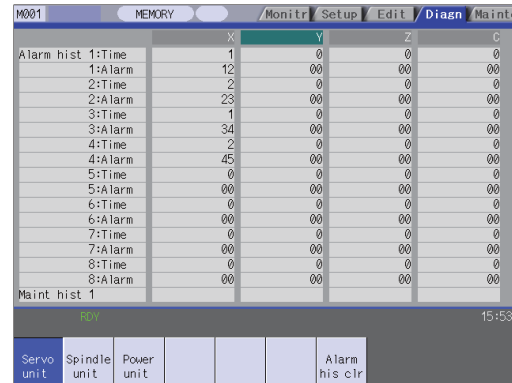

	X	Y	Z	C
Alarm hist 1:Time	1	0	0	0
1:Alarm	12	00	00	00
2:Time	2	0	0	0
2:Alarm	23	00	00	00
3:Time	1	0	0	0
3:Alarm	34	00	00	00
4:Time	2	0	0	0
4:Alarm	45	00	00	00
5:Time	0	0	0	0
5:Alarm	00	00	00	00
6:Time	0	0	0	0
6:Alarm	00	00	00	00
7:Time	0	0	0	0
7:Alarm	00	00	00	00
8:Time	0	0	0	0
8:Alarm	00	00	00	00
Maint hist 1				

Servo unit Spindle unit Power unit Alarm his clr

5.5 NC Memory Diagnosis Screen (NC Memory Diagn Screen)

The NC internal data can be displayed and rewritten on the screen. The custom API library's NC data read/write interface is used to display and rewrite the NC's internal data. The contents of the NC data can be displayed by designating the part system No., section No., sub-section No. and axis No. on this screen.

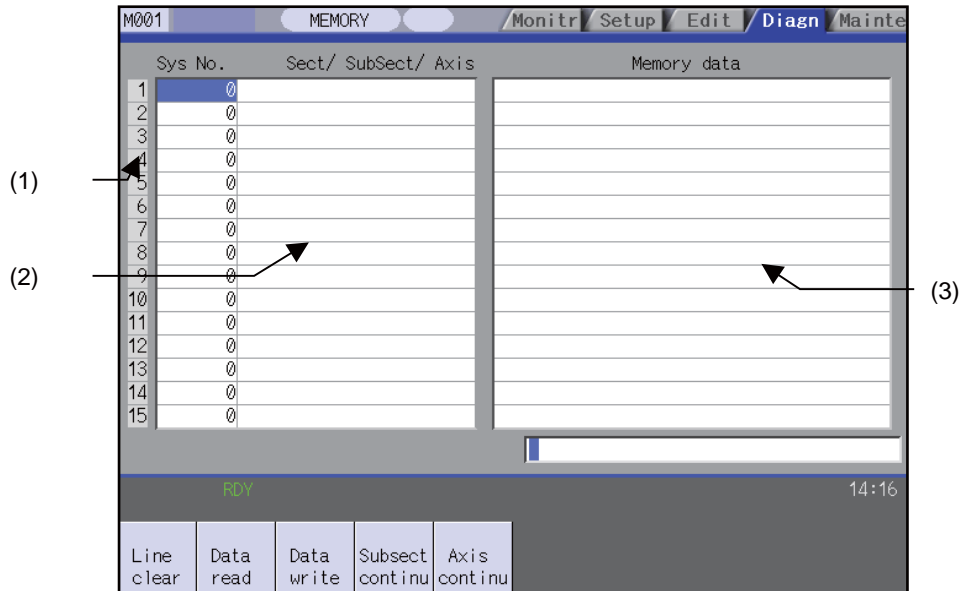

Display items

Display item	Details
(1) Index No.	This displays the registration No. of the NC memory data. When one of the "2. Data contents" is set, the number is highlighted indicating that the normal display of the data contents has stopped.
(2) Data contents	Part system No.: Designate the part system No. Designate "0" to designate the data common for the part systems. (The E70 Series is one-part system control.) Section/sub-section/axis: Designate the section No., sub-section No. and axis No. of the data to be set and displayed. The setting format is, section No./sub-section No./axis No. (Note) The axis No. "1" is handled as the first axis. Designate "0" for the data which does not require an axis designation.
(3) Memory data	This displays the contents of the data.

Menus

Menu	Details	Type	Reference
Line clear	This erases the information in the line where the cursor is. (One entire line becomes blank.) The cursor does not move at this time.	C	
Data read	The contents of the set address data (Part system No, Section/sub-section/axis) for all the lines are constantly displayed.The Index No. highlight (indicating data is being set) is released.The cursor appears in "Part system No" of that line.	C	5.5.1 Writing/Reading the Data Using the NC Data Designation
Data write	This writes the data (Note) in the setting area to the NC memory indicated by address data at the cursor position.The Data No. highlight (indicating data is being set) is released, and constant display is started.After writing, the cursor moves to "Part system No" of the next line.	A	
Subsect continu	Based on the data of the address data where the cursor is, this displays the continuous data to which the sub-section No. has been added to the address data from the line where the cursor is.The cursor moves to "Part system No " of that line.	C	
Axis continu	Based on the data of the address data where the cursor is, this displays the continuous data to which the axis No. has been added to the address data from the line where the cursor is.The cursor moves to "Part system No " of that line.	C	

(Note) Decimal, hexadecimal, floating point data and character string data writing is possible.
 Note that hexadecimal, floating point data and character strings may not be settable depending on the data.

- Decimal : Integers without decimal points ... (Example) -1234
- Hexadecimal : An "H" is necessary at the end ... (Example) 1234H
- Floating point data : Data with a decimal point ... (Example) -12.3
- Character string data : Character string..... (Example) X

5.5.1 Writing/Reading the Data Using the NC Data Designation

When reading the Process parameter "#8007 Auto corner override", the following data is set.

(Example)

Part system No.:1
 Section No. :126
 Sub-section No.:8007
 Axis name :0

Setting the data

- | | | | |
|-----|--|---|--|
| (1) | Using the cursor keys, move the cursor to the "Part system No." position. | ➔ | The cursor moves to the "Part system No." position. |
| (2) | Set the part system No.1 [INPUT] | ➔ | The index No. is highlighted, and the set value is displayed. The cursor moves to the right item position. |
| (3) | Separate the section No., sub-section No., axis No. with a "/", and set.126/8007/0 [INPUT] | ➔ | The set value appears. The cursor moves to the next "Sys No." line position. |
| (4) | Move the cursor to the set line position of "Sys No.", press the menu key [Data write] . | ➔ | The cursor moves to "memory data". |
| (5) | Set the data, and press the [INPUT] key. | ➔ | Write processing is executed. The Index No. highlight returns to normal. |

Reading the data

- | | | | |
|-----|---|---|---|
| (1) | Set the part system No., section No., sub-section No., axis No. in the same way as step "Setting the data". | | |
| (2) | Press the menu key [Data read] . | ➔ | The index No. highlight is released, and the normal display of the memory data starts. The data format (data size, display format) of the data displayed in the memory data differs according to the data type to be displayed. |

(Note) The cursor is constantly displayed. Using the cursor keys, the cursor can be moved to the part system No. area, section/sub-section/axis area.

5.6 Alarm Screen

A list of currently occurring alarms or messages can be displayed on this screen.

The displayed messages include the NC alarms, stop codes, alarm messages, operator messages, etc.

A history of alarm information can be displayed also.

■ NC message

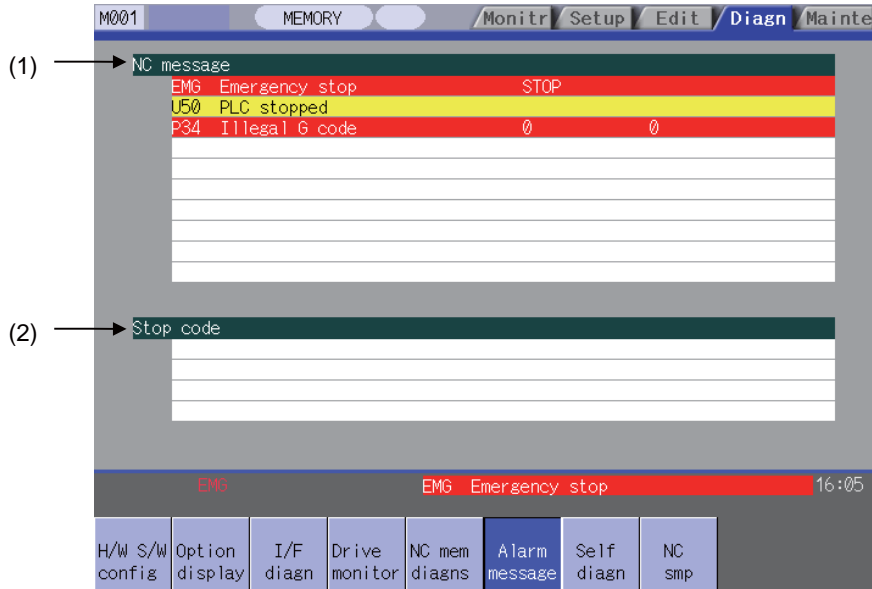

■ PLC message

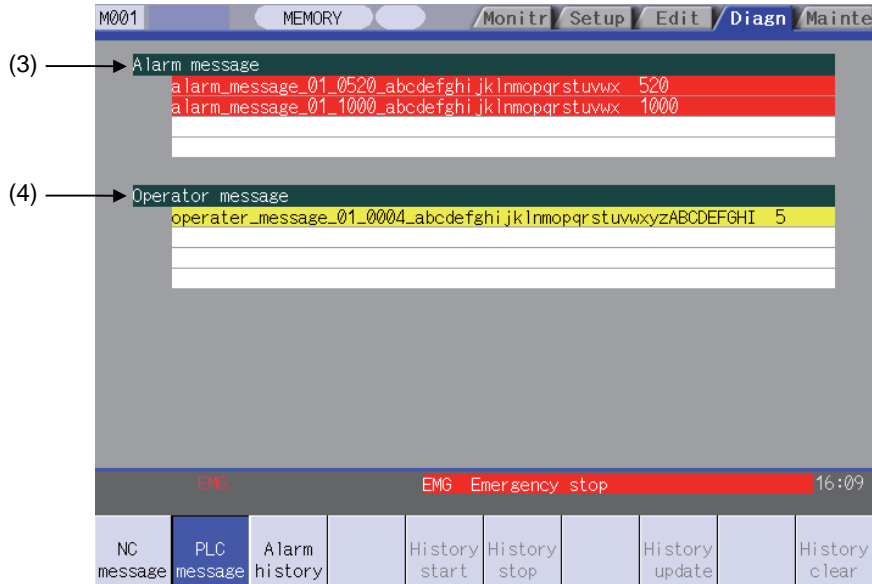

Display items

Display item	Details
(1) NC alarm	This displays the operation alarms, program errors, MCP alarms, servo alarms, system alarms, etc. Up to 10 messages are displayed in order of priority.
(2) Stop code	This displays the automatic operation status or stop status during automatic operation. Up to 4 messages are displayed in order of priority.
(3) Alarm message	Using the PLC programs, this displays messages such as details of machine abnormalities. Up to 4 messages are displayed.
(4) Operator message	Using the PLC programs, this displays operator information messages. Macro alarm messages are also displayed in this field. Up to 4 messages are displayed.

Message display colors

The messages are color-coded in the following manner.

Message type		Character color	Background color
NC message	Alarm	White	Red
	Warning	Black	Yellow
Stop code		Black	Yellow
Alarm message		White	Red
Operator message		Black	Yellow

Axis name display

The axis name is displayed in messages for each axis. The axis name is displayed as shown below according to the axis type.



Axis type	Axis name display	Display example	Remarks
NC axis	Control axis name (Name of axis in part system)	XYZ	If the same message occurs for each part system, several NC axes are displayed together.
Spindle	'S' + spindle No.	S1S2	If the same message occurs, several spindles are displayed together.
PLC axis	'P' + PLC axis No.	P1P2	If the same message occurs, several PLC axes are displayed together.
Auxiliary axis	'A' + auxiliary axis No.	A1A2	If the same message occurs, several auxiliary axes are displayed together.

If the same message occurs for different axis types, they will appear as separate messages.

Part system display

The E70 Series is one-part system control. The part system name does not appear for the 1-part system.

Menus

Menu	Details	Type	Reference
Alarm history	This displays the first page of the alarm history. The history sequentially displays 16 alarms per page from the latest alarm. If there are two or more NC alarms of same day and time, the alarms are sequentially displayed from the alarm and warning. Page is changed by  , and older histories are displayed. Page is changed by  , and newer histories are displayed.	B	
History start	The data collection of the alarm history is started. The operation message "The collection begin? (Y/N)" appears. When the [Y] or [INPUT] key is pressed, the data collection is started after the operation message "The collection begin" appears. Press the [N] or other than [INPUT] key when the data collection will be not started/restarted.	C	
History stop	The data collection of the alarm history is stopped. The operation message "The collection stop? (Y/N)" appears. When the [Y] or [INPUT] key is pressed, the data collection is started after the operation message "The collection stop" appears. Press the [N] or other than [INPUT] key when the data collection will be not stopped.	A	
History update	The alarm information of history is updated. When the history is updated, the page with latest alarm information (first page) is displayed. The history is updated even if changing to another screen, and returning to the alarm history screen.	C	
History clear	The alarm information of history is cleared. The operation message "Execute the collection data clear?(Y/N)" appears. When the [Y] or [INPUT] key is pressed, the alarm information of history is cleared after the operation message "Data clear complete" appears. The first page is displayed when the history is cleared.	A	

(Note 1) [History start], [History stop], [History update] and [History clear] menus are valid when the alarm history function is valid and [Alarm history] menu is selected.

(Note 2) When the alarm history function is used for the first time, clear the alarm history contents by pressing [History clear] menu. Unnecessary data may be recorded in the alarm history.

5.7 Self Diagnosis Screen

The H/W state and NC operation state can be confirmed on this screen.

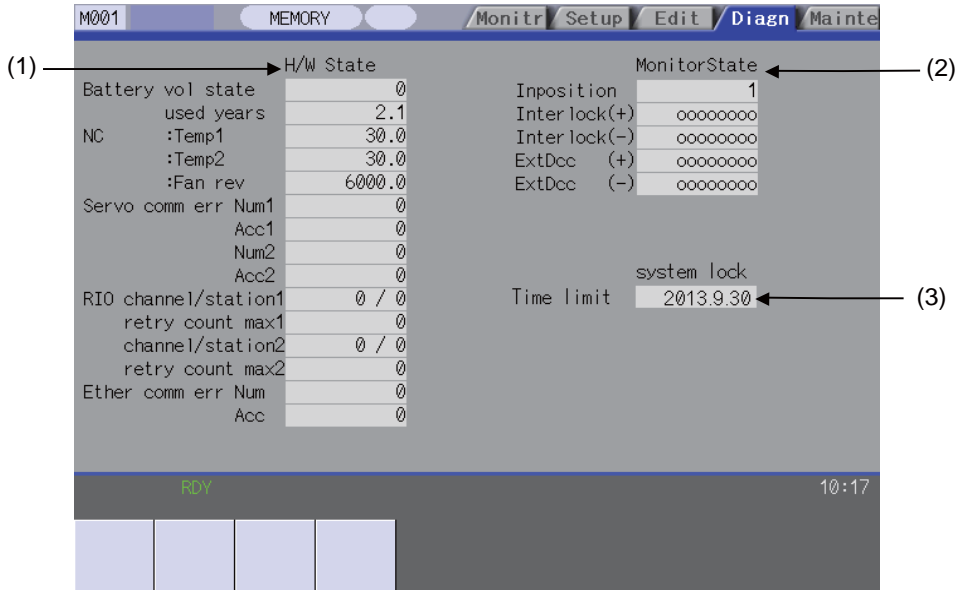

Display items

Display item	Details
(1) H/W state	This displays H/W state of NC unit and display unit.(Note 1)
(2) Operation state	This displays the state when the operation seems to be stopped in spite that the alarm does not occur. (Note 2)
(3) System lock	This displays the valid term by the System lock when the System lock is valid. This does not display when the System lock specification is invalid.

(Note 1) As for the NC unit, the contents are as follows.

NC



Display item	Details	
Battery vol state	This displays the current state of the battery voltage as 0 to 3 below.	
	Condition	Classification
	0 (normal state)	-
	1 (battery drop)	Cautions (gray)
	2 (detector error) 3 (no battery)	Warning (yellow)
used years	This displays approximate time of the battery used from the last replacement.	
	Condition	Classification
	Recommended battery use (5 years) <= Time for the battery used	Warning (yellow)
NC :Temp1	This displays the current temperature of the control unit.	
	Condition	Classification
	69° C < Control unit temp. <= 75° C	Cautions (gray)
	75° C < Control unit temp.	Warning (yellow)
NC :Temp2	Not displayed	
Fan rev	Not displayed	

Menus

Menu	Details	Type	Reference
Servo clear	This clears the cumulated count of the servo communication error 1 and 2 to "0".	A	Clearing the cumulated counter to zero
RIO clear	This clears the cumulated count of the RIO communication error to "0".	A	
Ether clear	This clears the cumulated count of the Ether communication error to "0".	A	
Battery clear	This clears the time the battery has been used to "0".	A	

Clearing the cumulated counter to zero

(Example) Clearing the cumulated count of the servo communication error

- (1) Press the menu [Servo clear] .  A operation message will be displayed.
- (2) Press [Y] or [INPUT] .  The cumulated count of the servo communication error 1 and 2 will be cleared to "0".When other keys are pressed, it will not clear to "0".

This also applies to [RIO clear] , [Ether clear] and [Battery clear] menu.

5.8 Data Sampling Screen

Sampling start/stop, sampling state display, setting the sampling parameters necessary for sampling are performed in the data sampling screen. The NC internal data (speed output from NC to the drive unit, or feedback data from the drive unit, etc.) can be sampled.

Also, the sampling data can be output externally on the I/O screen under the [Mainte] tag.

Sampling specifications

- Sampling cycle : 1.7ms * magnification
- Number of sampled axes : 1 to 20 axes (Servo axis 1 to 16 + Spindle 1 to 4)
- Number of sampling channels : 1 to 8 points
- Number of sampled data items : Max. 1,310,720 points

(Note 1) The maximum number of sampled data items is the total number of data. When the number of sampled channels is increased, the number of data per channel will decrease.

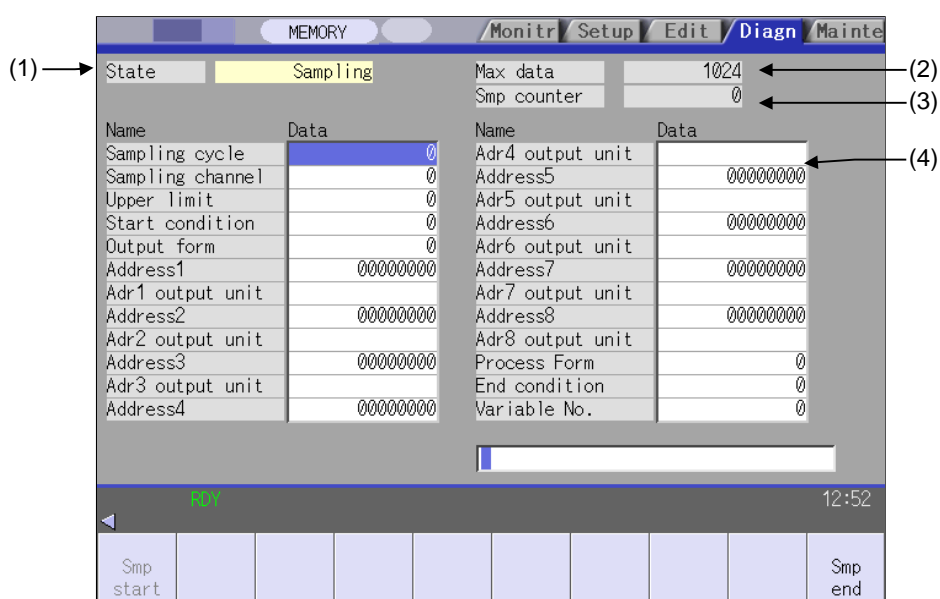

Display items

Display item		Details						
(1)	State	This displays the current sampling status. (The displays, "Sampling" and "Trigger wait" are highlighted.) Sampling : Sampling is being executed. Sampling stop : Sampling is not being executed, or the sampling process has completed. Trigger wait : When the "Start condition" is not set to "0" (manual start), this indicates a state waiting for the sampling to start, detecting the trigger, after the menu [Samp start] is pressed.						
(2)	Maximum data	This displays the maximum number of data possible for sampling. Normally, the number of data calculated from the setting value of "Upper limit" is displayed. The maximum number is 50% of the DRAM available memory.						
(3)	Sampling counter	This displays the position of the sampling buffer during the sampling process. When the ring buffer is valid, the head of the buffer can be seen with the value of the counter at the end of sampling. <div style="text-align: center;"> <p>Sampling buffer</p> <table border="1" style="margin-left: auto; margin-right: auto;"> <tr><td>0</td></tr> <tr><td>1</td></tr> <tr><td>:</td></tr> <tr><td>n-1</td></tr> <tr><td>n</td></tr> <tr><td>:</td></tr> </table> <p style="margin-left: 100px;">End of buffer (newest data)</p> <p style="margin-left: 100px;">Head of buffer (oldest data)</p> </div> <p>Sampling counter (n) →</p>	0	1	:	n-1	n	:
0								
1								
:								
n-1								
n								
:								
(4)	Sampling parameter	This displays and sets the parameters necessary for sampling.						

Menus

Menu	Details	Type	Reference
Samp start	This starts sampling. This menu cannot be selected under the "Sampling" state. When the trigger is set (the "Start condition" is not set to "0"), the state will be "Trigger wait" until the trigger is detected. The sampling will not stop even if transferred to another screen during sampling. If this menu is pressed when the parameter "#1224 aux08/bit0" is set to "0", the operation message "Can't start sampling" is displayed, and the operation will not start.	C	
Samp end	This stops sampling, and the state will be "sampling stop". The menu [Samp start] can be selected.	C	

5.8.1 Sampling Parameter

Parameter	Details	Setting range (unit)
Sampling cycle	Set the sampling cycle. Cycle = 1.7ms * setting value (Example) When the setting value is 1: 1.7ms cycle When the setting value is 2: 3.5ms cycle	1 to 255
Sampling channel	Set the number of sampling channel. - The sampling buffer will be divided by the set number of channels. When the number of sampling channels is increased, the number of data per channel will decrease.	1 to 8
Upper limit	Set the capacity of the buffer to be used for sampling. Buffer capacity = (setting value + 1) * 1024 items (Example) When the setting value is 0: 1024 items When the setting value is 1: 2048 items	0 to 1279
Start condition	Select the condition for starting sampling. 0:Manual start Sampling starts when [Smp start] menu is pressed. 1:Variable No. Sampling starts when the variable set in "Variable No." is 0 or a value other than null. (Note 2) (Note 5) 2:PLC device Sampling starts at the rising edge of the signal set in "PLC device". (Note3) 3:Address condition, true Sampling starts when "Address", "Data" and "Data mask" conditions are true. (Note1) 4:Address condition, false Sampling starts when "Address", "Data" and "Data mask" conditions are false. (Note1)	0 to 4
Output form	Select the data format when outputting the sampling data in text style. 0 : Outputs in decimal figure 1 : Outputs in hexadecimal figure with 8 digits - When "Output form" is set to "1", and "#1004 ctrlunit" is "E (1nano)", the data larger than 1m will not be output correctly. When the output data exceeds 1m, the low-order 32bits of the sampling data will be output. - Refer to the section "5.8.2 Outputting sampling data" for details on sampling data output.	0, 1
Address1 : Address8	Set the sampling address. There are two ways: designating an already prepared data by its index No., and designating the PLC device. Refer to the section "5.8.1.1 Sampling Address" for details.	
Adr1 output unit : Adr8 output unit	Set output unit for the sampling data of the each address. 0(blank):Outputs with #1004 ctrl_unit (Control unit). B:Outputs in micrometre C:Outputs in sub-micrometre D:Outputs in 10 nanometre E:Outputs in 1 nanometre S:Outputs in conventional interchangeable pulse of the spindle - S setting is enabled only for index No. method with spindle setting. The output unit will be the same as C (sub-micrometre) setting for index No. method with non-spindle setting (including NC axis setting).	0,B,C,D,E,S

Parameter	Details	Setting range (unit)
Process Form	<p>Set the sampling process type.</p> <p>0:One-shot The sampling stops when buffer is full.</p> <p>1:Repeat valid After the process ends (the buffer is full), the "Trigger wait" state will be entered again.</p> <p>2:Ring buffer valid Sampling is executed as a ring buffer.</p> <p>- If a value other than "0" is set, the "End condition" must also be set. If not, the sampling process will not end until it is forcibly ended.</p>	0 to 2
End condition	<p>Select the condition for ending the sampling process. (Note 4)</p> <p>0:Sampling completed When the buffer is full, the sampling ends.</p> <p>1:Variable No. Sampling ends when the variable set in "variable No." is 0 or null (Note 2)</p> <p>2:PLC device Sampling ends at the falling edge of the signal set in "PLC device". (Note 3)</p> <p>3:Address condition, true Sampling ends when "address", "data" and "data mask" conditions are true. (Note 1)</p> <p>4:Address condition, false Sampling ends when "address", "data" and "data mask" conditions are false. (Note 1)</p>	0 to 4
Variable No.	<p>This sets the variable No. that functions as the start/end trigger.If a number that does not exist is input, an error will occur.</p> <p>0:System variable (#1299) Other than 0:Designated common variable(#100 or more, #500 or more)</p> <p>- If both "Start condition" and "End condition" are set to other than "1" (variable No.), the value will be ignored even if set.</p>	0 to 999
PLC device	<p>This sets the PLC device that functions as the start/end trigger. When "*" is added at the head, the device will be a b contact.If a device that does not exist is input or the device No. is not within the setting range, an error will occur.</p> <p>0:Data sampling trigger signal (Y72C) Other than 0:Designated device</p> <p>- If both "Start condition" and "End condition" are set to other than "2" (PLC device), the value will be ignored even if set.</p>	(*)X0000 to (*)X1FFF (*)Y0000 to (*)Y1FFF
Address	<p>This sets the address targeted for applying "Data mask". (Note 1) However, if an illegal address (highest-order bit 0) is input, an error will occur.</p> <p>- If both "Start condition" and "End condition" are set to other than "3" or "4" (address conditions, true/false), the value will be ignored even if set. This item can be set with the same methods as "address 1 to 8".</p>	-
Data	<p>This sets the data for judging the results of applying "Data mask" on "Address".</p> <p>- If both "Start condition" and "End condition" are set to other than "3" or "4" (address conditions, true/false), the value will be ignored even if set.</p>	-
Data mask	<p>This sets the data mask to be applied on "Address".</p> <p>- If both " Start condition " and " End condition" are set to other than "3" or "4" (address conditions, true/false), the value will be ignored even if set.</p>	-

(Note1) When "3" or "4" is set in "Start condition", be sure to set the address, the data, and the data mask. This applies to "End condition" as well. If these are not set, sampling may not start.
When the same values are set in both "Start condition" and "End condition", sampling will not take a place.

Example of "End condition" by setting address	
Setting	End condition : 3
	Address : 12345678
	Data : 00000100
	Data mask : 0000FFFF
Meaning of setting	The trigger for sampling end turns ON when the results obtained by applying data mask "0000FFFF" on the data of which address is "12345678" matches "00000100".

- (Note 2) When "1" is set in "Start condition"/"End condition", the common variable uses the floating decimal point type. Thus, if the calculation results are used, an error will occur, and the value may not be recognized as "0" because of its calculation error.
- (Note 3) The variable data settings are validated immediately only from the program. These will not be validated immediately with settings from the screen or an external input.
- (Note 4) Even if "End condition" is satisfied, the subsequent flow will differ according to the value set in "Process type". (This also applies when ending manually.)



#21 Process type	Flow of sampling process			
One-shot		Sampling	Sampling stopped	
Repeat		Sampling	Waiting for trigger	Sampling
				Sampling stopped
Ring buffer		Sampling		Sampling stopped

(Note 5) If the "start condition" is set to "1", the "process form" needs to be set to "2: ring buffer valid".

5.8.1.1 Sampling Address

Set the sampling address.

*If the set addresses exceed the specified number of channels, they will be ignored.

(1) Index No. designation

The index No. is fixed regardless of the axis configuration.
 The following shows how to set the lower 6 digits of address.
 (No setting for the higher 2 digits is interpreted as "00".)

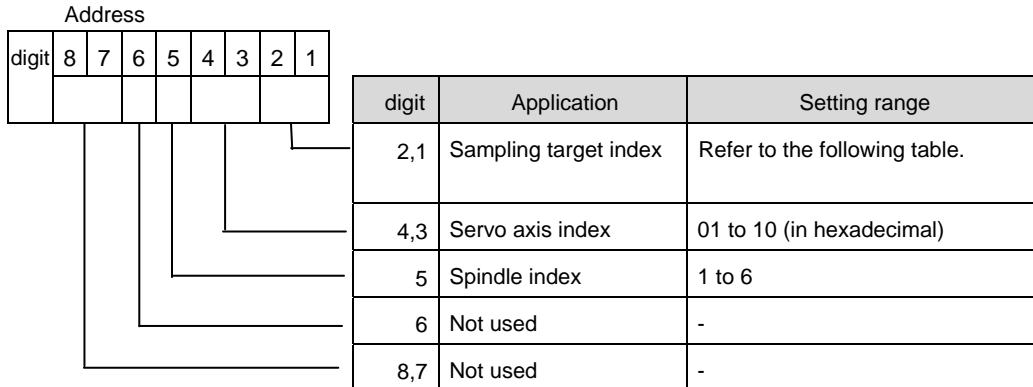

Index	Sampling data	Servo axis	Spindle	Unit
00	Feedback position	○	○	Refer to "Adr n output unit" in "5.8.1 Sampling Parameter"
01	Commanded position	○	○	
9B	Spindle cutting torque output value (R6528)	-	○	1%
9C	Current feedback (for cutting torque estimation)	-	○	0.1%
9D	Speed command (for cutting torque estimation)	-	○	0.01r/min
9E	Flux command (for cutting torque estimation)	-	○	0.1%
9F	Estimated disturbance torque (after R5492)	○	-	1%/0.01%

Setting range (index No.)

Servo axis	1st axis	2nd axis	...	16th axis
Feedback position	000100	000200	...	001000
Commanded position	000101	000201	...	001001

Spindle	1st axis	2nd axis	...	6th axis
Feedback position	010000	020000	...	060000
Commanded position	010001	020001	...	060001

*Setting examples for each purpose are shown below.

- For synchronized tapping : 3rd servo axis feedback (000300) - 1st spindle feedback (010000)
- For high-accuracy (roundness) : 1st servo axis feedback (000100) - 2nd servo axis feedback (000200)
- For spindle synchronization : 1st spindle feedback (010000) - 2nd spindle feedback (020000)

(2) PLC device designation methods

Designate "/" at the head and then designate the PLC device name.

If a word device is used, the size designation is required subsequently. Bit designation is also possible.

The designation methods are as listed below.

Designation method	Description
/PLC device name	Only for bit device. 1 bit data is output.
/PLC device name, size	Only for word device. Designate S, D, or Q for size. S: Single Word: 2 byte (16 bit) data is output. D: Double Word: 4 byte (32 bit) data is output. Q: Quad Word: 8 byte (64 bit) data is output.
/PLC device name, size, bit	Only for word device. Designate bit number 0 to 63 (decimal). Designated bit is output to the position of bit 0.

The format of output data follows the setting of output type (0: decimal / 1: hexadecimal).

The number of output digits for a word device of hexadecimal output varies depending on the size designation (S: 4 digits, D: 8 digits, or Q: 16 digits).

Ex. 1) When a bit device is designated

PLC device value	
X800	0
YC2D	1

Address designation	Output result	
	Output type	
	0 (Decimal)	1 (Hexadecimal)
/X800	0	00000000
/YC2D	1	00000001

Ex. 2) When a word device is designated

PLC device value	
R7500	0x86A0
R7501	0x0001
R7502	0X0D40
R7503	0X0003

Address designation	Output result	
	Output type	
	0 (Decimal)	1 (Hexadecimal)
/R7500,S	34464	86A0
/R7500,D	100000	000186A0
/R7500,Q	858993459300000	00030D40000186A0
/R7500,S,10	1	0001
/R7500,D,20	0	00000000
/R7500,Q,49	1	0000000000000001

The below listed PLC devices are able to be designated.

Device	Device range	Units	Details	Bit No. Size designation
X	X0 to X1FFF	1bit	Input signals to the PLC	×
Y	Y0 to Y1FFF	1bit	Output signals from the PLC	×
M	M0 to M10239	1bit	Temporary memory	×
F	F0 to F1023	1bit	Temporary memory Alarm message interface	×
L	L0 to L511	1bit	Latch relay	×
SM	SM0 to SM1023	1bit	Special relay	×
SB	SB0 to SB1FF	1bit	Special relay	×
SW	SW0 to SW1FF	16bit	Special register	○
T ※	T0 to T703	1bit	Timer	×
ST ※	ST0 to ST63	1bit	Incremented timer	×
C ※	C0 to C255	1bit	Counter	×
D	D0 to D2047	16bit	Data register	○
R	R0 to R32767	16bit	File register	○
B	B0 to B1FFF	1bit	Link relay	×
V	V0 to V255	1bit	Edge relay	×
SD	SD0 to SD1023	16bit	Special register	○
W	W0 to W1FFF	16bit	Link register	○

○ : Possible / × : Not possible

- * The output contact, setting value, and present value can also be obtained for T, ST, and C devices. The size designation is not required and bit No. designation is not possible for the following devices.

Device range	Units	Details
1000 + Device No.	1bit	Output contact
2000 + Device No.	16bit	Setting value
3000 + Device No.	16bit	Setting value

- Ex) - To obtain the output contact of T703: Designate "/T1703"
 - To obtain the setting value of C55: Designate "/C2055"
 - To obtain the present value of ST: Designate "/ST3001"

Note 1) A setting error occurs if a value out of the range is designated for the device No. or other PLC device is designated.

Note 2) For a word device, the device No. and bit No. which can be designated differ as follows depending on the designated size. A setting error occurs if a value out of the specification or out of the range is designated.

Size designation	Device No.	Bit No.
S	No limitation	0 to 15
D	Even number	0 to 31
Q	Multiple of 4	0 to 63

Note 3) A setting error occurs if "/" at the head is omitted and a PLC device name is designated.

Note 4) A setting error occurs if the size is not designated for a word device.

Note 5) A setting error occurs if the size or bit is designated for a bit device.

Note 6) The setting of address "n" output unit is disabled when a PLC device is designated.

Note 7) When a PLC device is designated with a zero-filled value such as "X00001", it is handled in the same manner as "X1".

5.8.2 Executing NC Data Sampling

Sampling is started when the menu [Samp start] is pressed.

Operation method (Executing NC data sampling)

(1) Set sampling condition and data.

(2) Press the menu [Samp start].



The sampling starts and the menu cannot be selected. When the sampling end condition is satisfied, the state will be "Sampling stop". The menu [Samp start] can be selected.

(Note 1) The sampling will not end even if transferred to another screen in sampling.

(Note 2) The data set in this function will not be output to the parameter.

(Note 3) The contents of "State" is returned to "Sampling stop". (The parameters related to NC data sampling is maintained.)

(Note 4) The data is displayed in 16 digits. However, the data can be set up to 8 digits.

5.8.3 Outputting Sampling Data

Sampling can be output on the data I/O screen under [Mainte] tag.

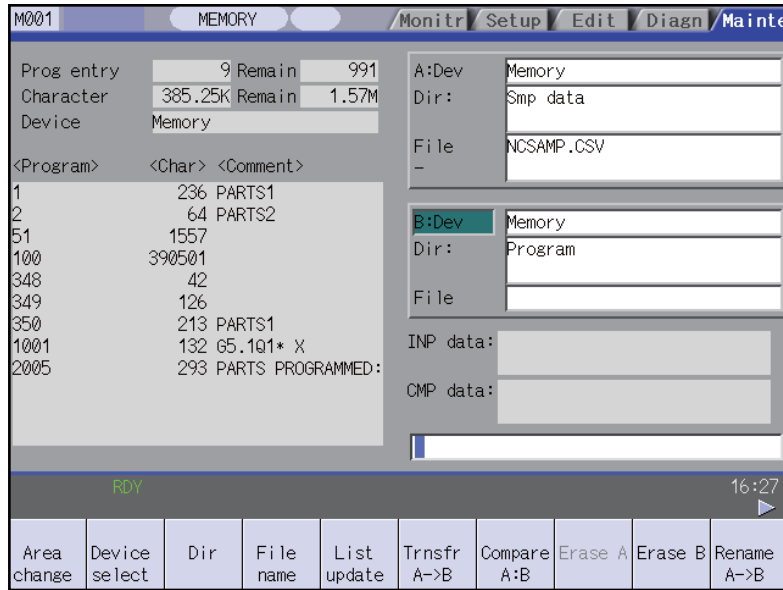

Operation method (Outputting the sampling data)

- (1) Select the data I/O screen under [Mainte] tag.
- (2) Select the menu [Area change] and select the menu [Memory]. ➔ "Memory" will display on A: Dev.
- (3) Select the menu [Dir] and select the menu [Smp data]. ➔ "Sampling data" will display on the directory and "NCSAMP.CSV" will on the file name.
- (4) Set the destination device, directory, file name in the setting column B.
- (5) Press the menu [Trnsfr A->B]. ➔ Sampling file will be output.

- (Note 1) The data can not be output when the sampling is not executed.
 (Note 2) The data can be output only when the sampling output valid parameter (#1224 aux08/bit0) is valid.
 (Note 3) The output format differs depending on the sampling parameter "Output form".
 (Note 4) The header information is not added to output sampling data.

Output file format (when output in decimal figure)

Sampling data is output in decimal figure when the sampling parameter "Output form" is set to "0".

(Example) When the number of channel is 3, the address is 1 to 3, and the output unit is E, it stops when 1ch is 100mm, 2ch is -100mm and 3ch is 50mm.

	Output format		
	1ch	2ch	3ch
1st data	200000000	-200000000	100000000
2nd data	200000000	-200000000	100000000
3rd data	200000000	-200000000	100000000
:	:	:	:

Output file format (when output in hexadecimal figure)

Sampling data is output in hexadecimal figure with 8 digits when the sampling parameter "Output form" is set to "1". The output data is the sampling buffer dumped in the length of the long type data (32bits).

(Example) When the number of channel is 3, the address is 1 to 3, and the output unit is C, it stops when 1ch is 100mm, 2ch is -100mm and 3ch is 50mm.

Channel		Output format
1st data	1ch	0001E840
	2ch	FFE17B80
	3ch	000F4240
2nd data	1ch	0001E840
	2ch	FFE17B80
	3ch	000F4240
3rd data	1ch	0001E840
	2ch	FFE17B80
	3ch	000F4240
:		:



Maintenance Screens

The NC memory can be formatted, the absolute position parameters setting, the SRAM backup, etc. are possible on this screen. Important operations are protected with a password.

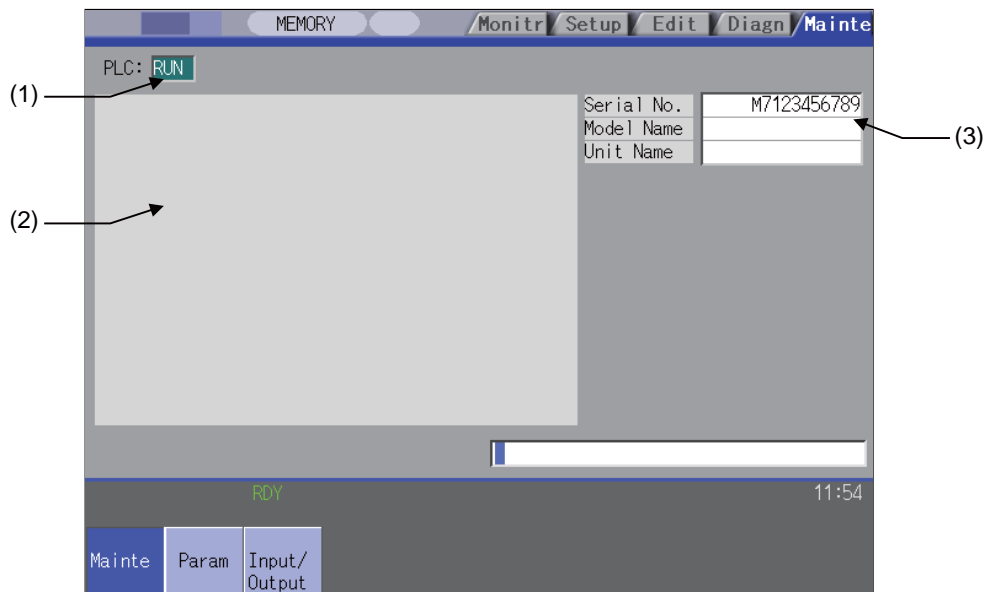

Display items

Display item	Details
(1) PLC stop state	The PLC state (stopped/stop canceled) is displayed. Stopped:"STOP" is highlighted. Stop canceled:"STOP" is not highlighted.
(2) Explanation of menu operations	A brief explanation of the menu operations is displayed.
(3) Serial No.	Currently set NC information (serial No., model name and unit name) is displayed.

Menus

Menu	Details	Type	Reference
Psswd input	This changes the screen related to the maintenance by setting the password.	A	
PLC stop	This forcible stops the PLC ladder process. If this menu key is pressed in the stopped state, the stop is canceled.	C	
All backup	This backs up (saves) or restores (reloads) the file such as SRAM etc. to designated device.	C	6.3 All Backup Screen
System setup	This automatically executes necessary parameter setting for driving servomotor only by setting necessary minimum item.	C	6.4 System Setup Screen
Adjust S-ana	This changes the screen to that for adjusting the spindle analog output.	C	6.5 Adjust S-analog Screen
To Abs pos	This sets the absolute position for servo axis (arbitrary NC axis, PLC axis).	C	6.6 Absolute Position Setting Screen
Servo diagn	This displays the diagnosis information on the servo axes (NC axis, PLC axis).	C	6.8 Servo Diagnosis Screen
Collect set	This executes the followings. Setting to collect the diagnosis data Confirming the diagnosis data collection status Starting/Stopping to collect the diagnosis data Clearing the diagnosis data	C	6.9 Diagnosis Data Collection Setting Screen
Format	This formats the NC memory.	A	
T-life format	This formats the tool life management data.	A	
Serial No.Set	This changes the NC serial No.	A	
To In/out	This changes the screen to the Data Input/Output screen.	C	6.2 Input/Output Screen
To param	This changes the screen to the Parameter screen.	C	6.1 Parameter Screens
SRAM backup	This backs up the NC SRAM information on the memory card.	A	Backup the NC SRAM information
Ext PLC link	This changes the screen to the External PLC Link.	C	6.12 External PLC Link Screen

Backing up the NC SRAM information

- (1) Press the menu [SRAM backup]. A message appears to confirm the backup execution.
- (2) Press [Y] or [INPUT].  The backup is executed.
 Press a key other than [Y] or [INPUT] to cancel the backup. The data is backed up into the memory card. (If SRAM.BIN already exists, the original file will be saved as SRAM.BAK.)

6.1 Parameter Screens

The various parameters can be displayed and set on this screen.

The configuration of the all parameter screens is applied to one of the following five patterns.

<Pattern 1> This is the screen for setting the common parameters for the axis, device, etc.
(Process param, etc.)

M001 MEMORY			Monitr Setup Edit Diagn Mainte		
No.	Name	Data	No.	Name	Data
1026	Base axis I	X		<WRK COUNT>	
1027	Base axis J	C	8001	WRK COUNT M	30
1028	Base axis K	Z	8002	WRK COUNT	44
1029	Flat axis I	X	8003	WRK COUNT LIMIT	333
1030	Flat axis J	C		<AUTO TLM>	
1031	Flat axis K	Z	8004	SPEED	0
1084	Arc error	0.000	8005	ZONE r	0.000
1171	Tap return ovr	0	8006	ZONE d	0.000
1185	Feedrate F1	0		<AUTO CORNER OVR.>	
1186	Feedrate F2	0	8007	OVERRIDE	0
1187	Feedrate F3	0	8008	MAX ANGLE	0
1188	Feedrate F4	0	8009	DSC.ZONE	0.000
1189	Feedrate F5	0		<T-TIP OFFSET>	
1506	F1 upper limit	100000	8010	ABS.MAX	0.000
1507	F1 change constant	0	8011	INC.MAX	0.000

RDY 14:51

Process param	Ctrl param 1	Ctrl param 2	Axis param	Barrier data	Param number				
---------------	--------------	--------------	------------	--------------	--------------	--	--	--	--

<Pattern 2> This is the screen for setting the parameters having an array structure for each axis
(Axis param, etc.)

M001 MEMORY			Monitr Setup Edit Diagn Mainte		
No.	Name	X	Z	C	
1063	Manual dog-type	0	0	0	
8201	AX. RELEASE	0	0	0	
8202	OT-CHECK OFF	0	0	0	
8203	OT-CHECK-CANCEL	0	0	0	
8204	OT-CHECK-N	0.000	0.000	0.000	
8205	OT-CHECK-P	0.000	0.000	0.000	
8206	TOOL CHG.P	0.000	0.000	0.000	
8207	G76/87 IGNR	0	0	0	
8208	G76/87 (-)	0	0	0	
8209	G60 SHIFT	0.000	0.000	0.000	
8210	OT INSIDE	0	0	0	
8211	MIRR. IMAGE	0	0	0	
8212					
8213	Rotation axis type	0	0	0	

RDY 14:58

Process param	Ctrl param 1	Ctrl param 2	Axis param	Barrier data	Param number	Area copy	Area paste	Next axis	
---------------	--------------	--------------	------------	--------------	--------------	-----------	------------	-----------	--

<Pattern 3> This is the screen for setting parameters common for the axis and device, etc.
 The parameter names are not displayed
 (Machine error data, PLC constant, etc.)

No.	Data	No.	Data	No.	Data	No.	Data
18001	0	18016	0	18031	0	18046	0
18002	0	18017	0	18032	0	18047	0
18003	0	18018	0	18033	0	18048	0
18004	0	18019	0	18034	0	18049	0
18005	0	18020	0	18035	0	18050	0
18006	0	18021	0	18036	0	18051	0
18007	0	18022	0	18037	0	18052	0
18008	0	18023	0	18038	0	18053	0
18009	0	18024	0	18039	0	18054	0
18010	0	18025	0	18040	0	18055	0
18011	0	18026	0	18041	0	18056	0
18012	0	18027	0	18042	0	18057	0
18013	0	18028	0	18043	0	18058	0
18014	0	18029	0	18044	0	18059	0
18015	0	18030	0	18045	0	18060	0

RDY Input the password 15:11

PLC timer | PLC inc timer | PLC counter | **PLC constnt** | Param number

<Pattern 4> This is the screen for setting parameters having an array structure for each part system(Base system parameters, etc.)

No.	Name	\$1	\$2	\$3
1001	SYS_ON	1	0	0
1002	axisno	3	0	0
1003	iunit	B	B	B
1004	ctrl_unit	D	D	D
1005	plcunit	B	B	B
1006	mcpunit	B	B	B
1025	I_plane	Z		
1026	base_I	X		
1027	base_J	C		
1028	base_K	Z		
1029	aux_I	X		
1030	aux_J	C		
1031	aux_K	Z		

RDY Input the password 15:12

BaseSys param | BaseAx spec | BaseCom param | Axis spec | Zp-rtn param | Param number | Area copy | Area paste

(Note) The E70 Series is one-part system control.

<Pattern 5> This is the screen for setting the subprogram storage destination parameters

No.	Name	Data
8880	Subpro stor D0:dev	Memory
8881	:dir	/TEMP/
8882	Subpro stor D1:dev	M-Card
8883	:dir	
8884	Subpro stor D2:dev	
8885	:dir	
8886	Subpro stor D3:dev	
8887	:dir	
8888	Subpro stor D4:dev	
8889	:dir	
8890	Subpro srch odr D0	0
8891	Subpro srch odr D1	0
8892	Subpro srch odr D2	0

Input the following value of dev.
M:Memory R:M-Card

RDY 15:41

I/O param	Ethnet param	Link param	Subpro stor	Operate param	Param number				
-----------	--------------	------------	-------------	---------------	--------------	--	--	--	--



Menus

Menu	Details	Type	Reference
Param No.	A arbitrary parameter No. can be selected. When the parameter No. is set and the [INPUT] key is pressed, the parameters will appear with that No. at the head. The cursor will also move to that No.	A	
Area copy	This copies the parameter setting values in the designated range. The range is designated with numbers.	A	6.1.3 Copying/Pasting Parameters
Area paste	This pastes the range of parameters designated in area copy. They are pasted in a parameter corresponding to the axis or part system where the cursor is. Once copied, a parameter can be pasted any number of times until a new parameter is copied.	B	
Next Ax	This can be selected when there are five or more display axes. This is used in the screen for the parameters having an array structure for each axis.	C	-
Process param	This changes the screen to the user parameter screen. (Note) The barrier data is displayed only for the L specifications.	C	6.1.4 User Parameters
Ctrl param 1			
Ctrl param 2			
Axis param			
Barrier data			
I/O param			
Ethernet param			
Link param			
Subpro stor			
Operate param			

Menu		Details	Type	Reference
BaseSys param	PLC counter	This changes the screen to the Machine parameter screen. (Note 1)Normally, the machine parameters can be referred to, but cannot be set.	C	
BaseAx spec	PLC constnt			
BaseCom param	Bit select			
Axis spec	Er Comp param			
Zp-rtn param	Er Comp data			
Abs pos param	Macro list			
Servo param	Posn switch			
Spindle spec	PLCIndx param			
Spindle param				
PLC timer				
PLC inc timer				

6.1.1 Changing the Parameter Display

Changing to the computer link parameters

- (1) Press the menu change key until the menu [Link param] appears.  The menu [Link param] appears.
- (2) Press the menu [Link param].  The computer link parameters appears. The menu [Link param] is highlighted.

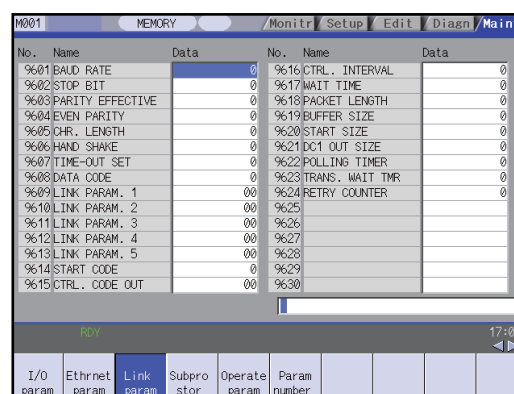

No.	Name	Data	No.	Name	Data
9601	BAUD RATE	0	9616	CTRL. INTERVAL	0
9602	STOP BIT	0	9617	WAIT TIME	0
9603	PARITY EFFECTIVE	0	9618	PACKET LENGTH	0
9604	EVEN PARITY	0	9619	BUFFER SIZE	0
9605	CHR. LENGTH	0	9620	START SIZE	0
9606	HAND SHAKE	0	9621	DC1 OUT SIZE	0
9607	TIME-OUT SET	0	9622	POLLING TIMER	0
9608	DATA CODE	0	9623	TRANS. WAIT TMR	0
9609	LINK PARAM. 1	00	9624	RETRY COUNTER	0
9610	LINK PARAM. 2	00	9625		
9611	LINK PARAM. 3	00	9626		
9612	LINK PARAM. 4	00	9627		
9613	LINK PARAM. 5	00	9628		
9614	START CODE	0	9629		
9615	CTRL. CODE OUT	00	9630		

17:06

I/O param	Ethnet param	Link param	Subpro stor	Operate param	Param number				
-----------	--------------	------------	-------------	---------------	--------------	--	--	--	--

6.1.2 Setting the Parameters

The method of setting the parameters is explained in this section. For the setting range of each parameter, refer to "Appendix 10 User Parameter List".

Press the menu key to select the parameter screen, and select the data to be set with the cursor key.

"8201 Axis removal" Setting Y1 axis to "1"

- (1) Press the menu [Axis param].
- (2) Use the [↓], [↑],  and  keys to move the cursor to the position to be set.  The cursor moves to the position of the setting target data.

The cursor can also be moved with the menu [Param No.] .Refer to "6.2.2 Selecting the parameter No.".

No.	Name	X1	Y1
8201	AX. RELEASE	0	0
8202	OT-CHECK OFF	1	1
8203	OT-CHECK-CANCEL	0	0
8204	OT-CHECK-N	0.000	0.000
8205	OT-CHECK-P	0.000	0.000
8206	TOOL CHG.P	0.000	0.000

The current setting value is displayed in the input area.

- (3) Input the value.
1 [INPUT]  The setting value appears, and the cursor moves.

No.	Name	X1	Y1
8201	AX. RELEASE	0	1
8202	OT-CHECK OFF	1	1
8203	OT-CHECK-CANCEL	0	0
8204	OT-CHECK-N	0.000	0.000
8205	OT-CHECK-P	0.000	0.000
8206	TOOL CHG.P	0.000	0.000

"8205 OT+" Setting X1 axis to "100.0" and Z1 axis to "200.0"

(1) Press the menu [Axis param] .

(2) Use the [↑] and [↓] keys to move the cursor to the position to be set.(The row does not need to be designated with the [←] and [→] keys.)

➔ The cursor moves to the position of the setting target data.

No.	Name	X1	Y1	Z1
8201	AX. RELEASE	0	1	0
8202	OT-CHECK OFF	1	1	1
8203	OT-CHECK-CANCEL	0	0	0
8204	OT-CHECK-N	0.000	0.000	0.000
8205	OT-CHECK-P	0.000	0.000	0.000
8206	TOOL CHG.P	0.000	0.000	0.000

The current setting value is displayed in the input area.

(3) Input the value.(Format: 1st row/2nd row/3rd row/4th row)100//200 [INPUT]

➔ The setting value appears, and the cursor moves.

No.	Name	X1	Y1	Z1
8201	AX. RELEASE	0	1	0
8202	OT-CHECK OFF	1	1	1
8203	OT-CHECK-CANCEL	0	0	0
8204	OT-CHECK-N	0.000	0.000	0.000
8205	OT-CHECK-P	100.000	0.000	200.000
8206	TOOL CHG.P	0.000	0.000	0.000

- (Note 1) If [PR] appears at the lower right of the screen when the parameter value is changed, the parameter value will be validated when the power is turned ON again.
- (Note 2) If the [INPUT] key is pressed without inputting a value, the cursor will move without changing the parameter setting value.
- (Note 3) If a character string, such as an axis name or input/output device name, is set in the parameter, the setting will be cleared when 0 is input and the [INPUT] key is pressed.
- (Note 4) Parameters for up to four rows, which are as currently displayed, can be set at once.
- (Note 5) If the parameter value for several rows is input simultaneously, the values will be set from the currently displayed left end no matter which row the cursor is currently at.

6.1.3 Copying/Pasting Parameters

Designating the cursor position and copying

(1) Move the cursor to the parameter to be copied.

(2) Press the menu [Area copy] and [INPUT].

➔ The menu is highlighted. The setting value of the parameter at the cursor position is highlighted.

No.	Name	X1
8201	AX. RELEASE	0
8202	OT-CHECK OFF	1
8203	OT-CHECK-CANCEL	0
8204	OT-CHECK-N	0.000
8205	OT-CHECK-P	100.000
8206	TOOL CHG.P	0.000

(Note) When the screen has an array structure for each axis or each part system, an error will occur if different rows (axis or part system) are designated for the copy start position and end position.

Copying by designating the parameter No. with key inputs

(1) Move the cursor to the display area of the axes or part system to be copied.

(2) Press the menu [Area copy].

➔ The menu is highlighted.

(3) Designate the copy range. Format: First No./Last No. 8203/8205 [INPUT]

➔ The copy target range is highlighted. The menu highlight returns to normal.

If the last No. to be copied is the last No. of the currently displayed parameter type, "E" can be designated. (Example) 8201/E If only one parameter is being copied, input only the No. of the parameter to copy, and then press the [INPUT] key.

No.	Name	X1
8201	AX. RELEASE	0
8202	OT-CHECK OFF	1
8203	OT-CHECK-CANCEL	0
8204	OT-CHECK-N	0.000
8205	OT-CHECK-P	100.000
8206	TOOL CHG.P	0.000

(Note 1) The copy target range highlight returns to the normal display by pasting. The copy target range is valid until the parameter type display is changed.

(Note 2) Only the currently displayed parameter types can be copied.

(Example) If the parameter numbers #1001 to #1028 of the base system parameter are designated as the copy target range, the base axis specification parameters #1013 to #1024 cannot be copied.

Pasting the copied data

(1) Move the cursor to the display area of the axes or part system where the data will be pasted.

(2) Press the menu key [Area paste].

➔ The menu is highlighted, and a message confirming the operation appears.

(3) Press [Y] or [INPUT].
The copied data will not be written in when the [N] key is pressed.

➔ The copied data is written to the parameter with the same number as when copied, in the area where the cursor is. The menu highlight returns to normal.

(Note) If the corresponding parameter is changed after the copy target range is designated, the changed value will be pasted.

6.1.4 User Parameters

The user parameter configuration is as shown below.

Parameter type	[Next axis] menu	[Area copy] [Area paste] menu
Process Parameter	-	-
Control Parameter 1	-	-
Control Parameter 2	-	-
Axis Parameter	△ (Note 1)	△ (Note 2)
Barrier data (Note 3)	-	○
Input/Output Parameter	-	-
Ethernet Parameter	-	-
Computer Link Parameter	-	-
Sub-program storage destination parameter	-	-
Operation Parameter	-	-

(Note 1) This is valid only when the total number of valid NC axes and PLC axes is five or more.

(Note 2) This is valid only when the total number of valid NC axes and PLC axes is two or more.

(Note 3) The barrier data appears only for the L specifications.

Operation methods (Subprogram storage destination parameters) Example 1

Setting the device (Example: Assign Memory to D1)

(1) Set the cursor to the "#8882 Subpro stor D1: dev" (D1 device).

(2) Input [M] , and press the [INPUT] key.  "Memory" appears at "#8882 D1: dev".The cursor moves down one line.

(Note) Input the following values for the device name.
M: Memory, R: Memory card

Operation methods (Sub program storage destination parameter) Example 2

Setting the directory (Example: Setting "/TEMP1/TEMP12/TEMP123" to D1)

(1) Set the cursor to "#8883 dir" (D1 directory)  The current "#8883 D1: dir" contents are echoed back to the input area.

(2) Set "/TEMP1/TEMP12/TEMP123", and press the [INPUT] key.  The value is set, and the cursor moves down one line.

6.1.5 Echo Back

If more than 14 characters can be set for the parameter, or for bit-related parameters, the parameter setting value at the cursor position appears at the input area. If more than 14 characters are set in the parameter, "... " will appear in the data field.

No.	Name	Data	No.	Name	Data
9701	IP addr auto set	0	9719	Host1 Wr d pos:cmnt	0
9702			9720	Host1 Wr d num:cmnt	0
9703			9721	Host1 no total siz	0
9704					
9705			9731	Host2 host name	
9706	Host No.	0	9732	Host2 user name	
			9733	Host2 password	
9711	Host1 host name		9734	Host2 directory	/bnc59/use...
9712	Host1 user name		9735	Host2 host type	0
9713	Host1 password		9736	Host2 Wr d pos:name	0
9714	Host1 directory		9737	Host2 Wr d pos:size	0
9715	Host1 host type	0	9738	Host2 Wr d pos:Dir	0
9716	Host1 Wr d pos:name	0	9739	Host2 Wr d pos:cmnt	0
9717	Host1 Wr d pos:size	0	9740	Host2 Wr d num:cmnt	0
9718	Host1 Wr d pos:Dir	0	9741	Host2 no total siz	0

Input field: /bnc59/user/pram

Parameters for which 14 or more characters can be set

No.	Data	No.	Data	No.	Data	No.	Data
6401	10101010	6416	00000000	6431	00000000	6446	00000000
6402	00000000	6417	00000000	6432	00000000	6447	00000000
6403	00000000	6418	00000000	6433	00000000	6448	00000000
6404	00000000	6419	00000000	6434	00000000	6449	10000000
6405	00000000	6420	00000000	6435	00000000	6450	00000101
6406	00000000	6421	00000000	6436	00000000	6451	00000000
6407	00000000	6422	00000000	6437	00000000	6452	00000000
6408	00000000	6423	00000000	6438	00000000	6453	00000000
6409	00000000	6424	00000000	6439	00000000	6454	00000000
6410	00000000	6425	00000000	6440	00000000	6455	00000000
6411	00000000	6426	00000000	6441	00000000	6456	00000000
6412	00000000	6427	00000000	6442	00000000	6457	00000000
6413	00000000	6428	00000000	6443	00000000	6458	00000000
6414	00000000	6429	00000000	6444	00000000	6459	00000000
6415	00000000	6430	00000000	6445	00000000	6460	00000000

Input field: 10101010

Bit-related parameters

6.2 Input/Output Screen

The Input/Output screen is used to carry out NC data input/output between the NC internal memory and the external input/output devices.

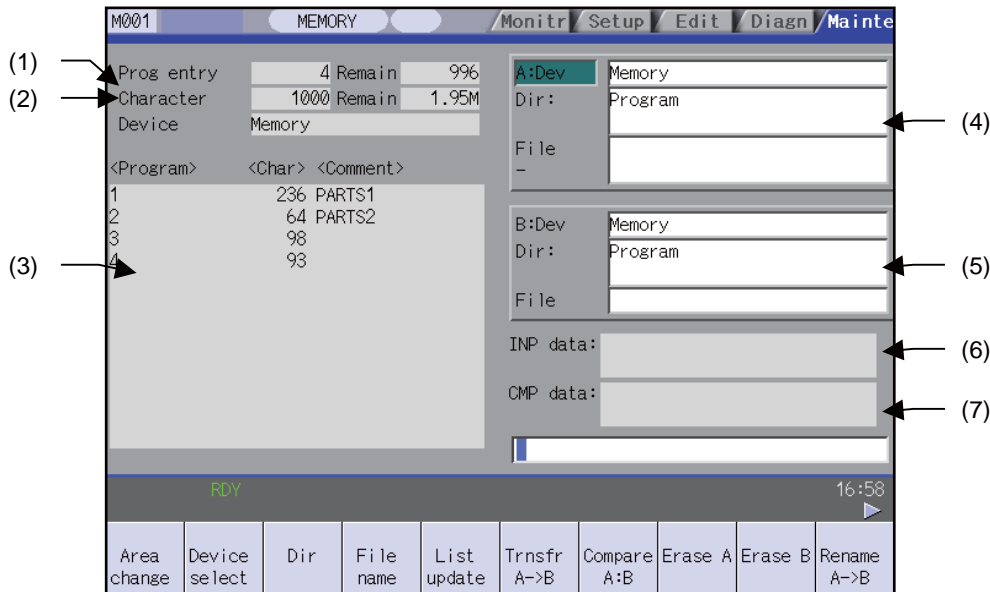

Display items

Display item	Details
(1) Number of programs registered and remainder (Note 2)	This displays the registration information of machining program of the selected device. Number of programs registered : This displays the number of programs previously registered as user machining programs. Remainder : This displays the remaining number of programs that can be registered. When "Memory" is selected as the device, the total of the number of programs registered and the remainder is the maximum number of registrations set in the specifications.
(2) Number of memory characters and remainder (Note 2)	This displays the number of characters of the machining program of the selected device. Number of memory characters : This displays the number of characters previously registered as user machining programs. Remainder : This displays the remaining number of characters that can be registered. The total of the number of memory characters and the remainder is the maximum number of memory characters set in the specifications.
(3) List (Note 3)	This displays a contents list (directory and file name) of the directory in the setting column (file setting column A or B) where the cursor is currently located. Program : When "Memory" is selected for the device, this displays the file name (program No.) of the machining programs already registered. The file names are displayed in order from the smallest number, from 1 to 99999999. When a device other than memory is selected, this displays the file name and directory to be included in the directory that is set in the current setting column. When the number of characters exceeds 12, the excess is indicated as "***". Character : The size of each file (when memory is selected for the device, the number of characters in the machining program). When directory is selected, this displays "DIR". Comment : This displays the comment (up to 17 alphanumeric characters and symbols) of each file. The date which the file is updated is displayed for the memory card, USB memory or Ethernet. When the number of characters exceeds 17, the excess is not displayed.
(4) File setting column A	This sets the device, directory, and file name of the target file for transfer, compare, erasing, etc., operations. When transferring, the file name of the transfer origin file is set. When renaming, the file name before renaming is set. When erasing, the erasing range is set. When the number of characters exceeds 28, the excess is not displayed.
(5) File setting column B	As for the device and directory, the setting values are retained even when the power is turned OFF. (Note 3)
(6) Input data	This displays the data being transferred.

Display item	Details
(7) Comparison data	This displays the data being compared. If an error occurs during comparison, the block with the error is displayed.

(Note 1) Depending on the device, some items are not displayed.

Display item	Device				
	Memory	Serial	Memory card	USB Memory	Ethernet
Number of programs registered	○	×	○	○	○
Remainder	○	×	×	×	×
Number of memory characters	○	×	○	○	○ *
Remainder	○	×	○	○	×
List	○	×	○	○	○
○ : Displayed × : Not displayed					

* When the Ethernet parameter "#97*1 Host n no total siz" is set to 1, the number of host memory characters will not appear.

(Note 2) The list does not appear when using serial.

(Note 3) When the number of characters in the directory path (full path) from the root directory exceeds 100, the directory path is not retained, but a previously set directory path containing 100 characters or less retained. When the device is "Memory", the initial directory display is "Program". When the device is "Ethernet", the initial directory display is "/" (root).

Menus

Menu	Details	Type	Reference
Area change	This changes the setting area to file setting column A (transfer origin) or file setting column B (transfer destination). The display of the valid area (A or B) is highlighted.	C	6.2.1 Changing the Valid Area
Device select	This displays the submenu of the machining program storage area. When the submenu is selected, the device is confirmed, and if a directory exists it is set in the root. The memory is selected as the default.	A	6.2.2 Selecting a Device, Directory, and File
Dir	This menu sets the directory that carries out input/ output operations, and is on standby for input. Note that when memory is selected for the device, the directory can be selected from the submenu.	A	
File name	This menu sets the file name that carries out input/ output operations, and is on standby for input. When memory is selected for the device, setting is not necessary if the directory is not the program.	A	
List update	This updates the list. The list of the directly selected in the currently valid file setting column (A/B) is updated.	C	
Transfr A→B	This copies the file in file setting column A (transfer origin) to the file setting column B (transfer destination). (The transfer origin file is not changed.) A message appears during transfer and when the transfer is completed.	B	6.2.3 Transferring a File
Compare A:B	This compares the files in file setting column A (transfer origin) and file setting column B (transfer destination).	C	6.2.4 Comparing Files (Compare)
Erase A	This erases the file in file setting column A. (Note) The NC memory (excluding programs), serial and Ethernet (host file) cannot be erased.	B	6.2.5 Erasing a File
Erase B	This erases the file in file setting column B. (Note) The NC memory (excluding programs), serial and Ethernet (host file) cannot be erased.	B	
Rename A→B	This changes the name of the file in file setting column A (transfer origin) to the name of the file in file setting column B (transfer destination). (Note) The same device must be selected for A and B. The NC memory (excluding programs) and serial cannot be renamed.	B	6.2.6 Changing a File Name
Comment nondisp	This changes whether to show or hide the comment field.	B	
Dir create	This creates a new directory in the directory of the currently valid file setting column (A/B). The directory can be created when memory card or USB memory is selected for the device.	A	6.2.7 Creating a Directory
Merge B→A	The file contents in the file setting column B are added to the file in the file setting column A. (The file in the file setting column B is not changed.) (Note) The NC memory (excluding programs), serial and Ethernet (host file) cannot be merged.	B	6.2.8 Merging a File
MemCrd format	The formats the front IC card.	A	6.2.9 Formatting an External Device
USB Mem format	This formats USB memory.	A	
Halt	This interrupts the process (transfer, compare, etc.) during execution.	C	

6.2.1 Changing the Valid Area

When setting the file setting field A or B device, directory and file name on this screen, the area containing these must be valid.

The display area can be changed by pressing the menu key ([Area change]) or the cursor key [↑] and [↓].
After changing, the data setting operation is valid in that area.

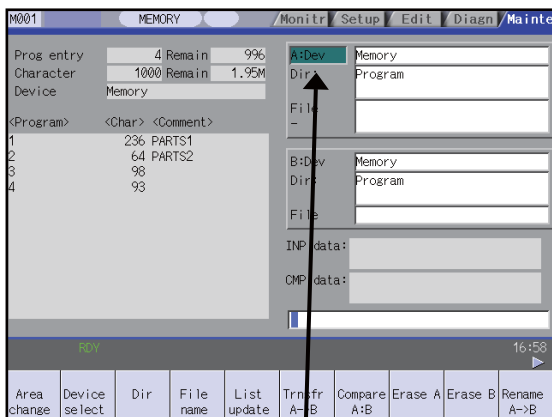

File setting field A is valid.

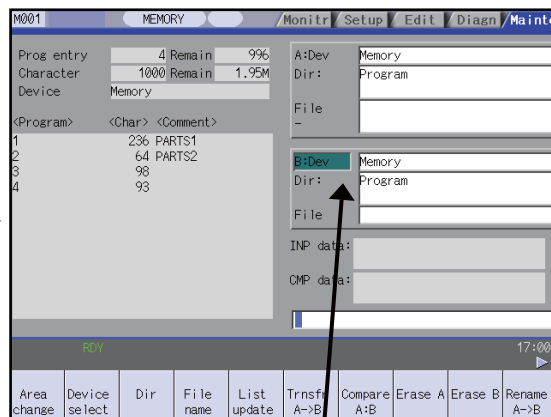

File setting field B is valid.

Changing the valid file setting field

When file setting field A (top) is valid

- (1) Press the menu [Area change].



The file setting field B (bottom) is validated.

This can also be changed with the cursor key [↓].

6.2.2 Selecting a Device, Directory and File

File selection sequence

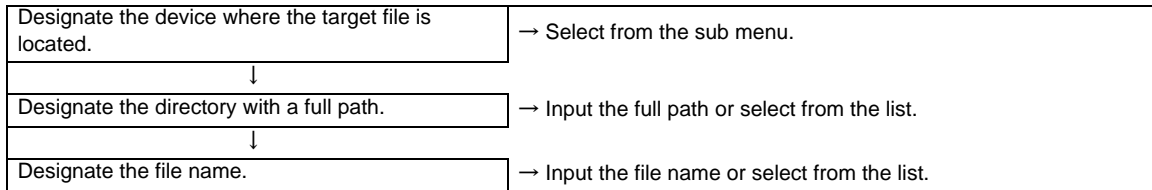

Menu used

[Device select] menu's submenus

Menu	Details	Type	Reference
Memory	This selects the NC memory (program, parameter, PLC program, NC data).	C	
Serial	This selects the RS-232C device (PC, tape, etc.).	C	
Memory card	This selects the front IC card.	C	
Ethernet	This selects the Ethernet-connected host computer.	C	
USB Memory	This selects USB memory.	C	

[Dir] (other than memory) and [File name] menu submenus

Menu	Details	Type	Reference
From list	The cursor appears in the list display. The list contents can be selected with the [INPUT] key. When a directory is selected, the contents of the selected directory are displayed in the list. Continued selection is possible. When a file name is selected, the file name is temporarily displayed in the input area. When the [INPUT] key is pressed again, it is fixed.	A	

Selecting methods for device, directory, and file name

Device	Designation target file	Designation method		
		Device	Directory	File name
NC memory	- Machining program - User macro - Fixed cycle	Select from the submenu	- (Default)	Key input in the input area, and press [INPUT] Select from the list
	Other than the machining program	Select from the submenu	Key input in the input area, and press [INPUT] Select from the submenu	- (Fixed)
Other than the NC memory	All	Select from the submenu	Key input in the input area, and press [INPUT]	Key input in the input area, and press [INPUT]
			Select from the list	Select from the list

The device can be selected from the submenu. (The devices that can be used will differ depending on the specifications.)

One of the following methods can be used to designate the directory (for devices other than the NC memory) and file name.

- Set the directory path (full path) or file name in the input area, and press the [INPUT] key.
- Press submenu [From list] of the menu [Dir] or [File name]. Move the cursor to the target directory or file name, and press the [INPUT] key.

A wild card (*) can be used when selecting a file name.

Notes when selecting a file

- (1) During directory and file name setting, the designated directory, path or file name will be set, even if it does not actually exist. This will not cause an error. Note that the previously set directory is overwritten.
- (2) When a file in the NC memory other than a machining program is designated, it is not necessary to set the file name. (The file name is fixed.)
- (3) When a file name is selected from the menu, it first is displayed in the input area. However, at this time the file name has not yet been fixed. Press the [INPUT] key again to fix the file name.
- (4) When the  key is pressed when setting a file name, the file name in the input area is erased.
- (5) When a fixed cycle program is designated, the basic common parameters "#1166 fixpro" must be set. Select "Memory" for the device, and "Program" for the directory.

Initial directory when the Ethernet is selected

An initial directory is specified at turning the power ON by the following parameter.

- #9706 Host No.
- #9714 Host1 directory
- #9734 Host2 directory
- #9754 Host3 directory
- #9774 Host4 directory

Selecting a NC memory program

(1) Press the menu [Device select].

(2) Press the menu [Memory].

➔ "Memory" appears in the device name, and the default "Program" appears in the directory.

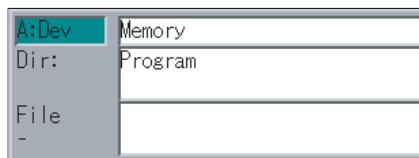

(3) Press the menu [File name].

<When inputting the file name from the input area>

(4) Input the file name
10013 [INPUT]

➔ Selected file name appears.

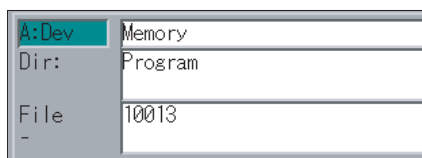

<When selecting the file name from the list>

(4) Press the menu [From list].

➔ The cursor appears in the list.

<Program>	<Char>	<Comment>
101	73	MAIN
102	53	SUB1
103	54	SUB2
10011	519	
10012	139	
10013	100	

(5) Move the cursor to directory and file name to be selected, and fix.

➔ Selected file name is displayed in the input area.

[↑], [↓] [INPUT]



(6) Press the [INPUT] key.

➔ The selected file name appears.

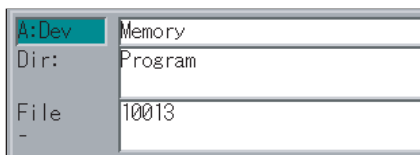

Designating multiple files

(1) Designating multiple serial files

Multiple serial files can be transferred, compared and erased in the file setting column A. Set as follows in this case.

File:First file name
-:Last file name



A:Dev	Memory
Dir:	Program
File	10013
-	10050

(2) Using a wild card

A wild card (*) can be used in the file name.

(Note) When serial is used, multiple files cannot be compared.

All files will be selected.

File:*
-



A:Dev	Memory
Dir:	Program
File	*
-	

Selecting a NC memory file other than a program

(1) Press the menu [Device select].

(2) Press the menu [Memory].



"Memory" appears in the device name, and "Program" appears as the default in the directory.

A:Dev	Memory
Dir:	Program
File	
-	

(3) Select the menu [Dir] .

(4) Press the menu [Tool offset].



The directory and file name appear.

A:Dev	Memory
Dir:	Tool offset
File	TOOL.OFS
-	

(Note 1) The file name for each directory is fixed. Refer to "6.2.10 List of file names" for the file names.

(Note 2) When the menu [Program] or [Program all] is selected, the setting of "File name" column is cleared.

Selecting a device file other than the NC memory (When separately selecting the directory and file name.)

(1) Press the menu [Device select].

(2) Select a device.



The device name appears. The root directory is selected as the default.

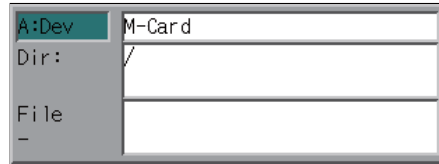

(3) Select the menu [Dir]

<When inputting the directory from the input area>

(4) Input the directory path as a full path.
/PRG/PRECU T [INPUT]

<When selecting the directory from the list >

(4) Press the menu [From list]



The cursor appears in the list.

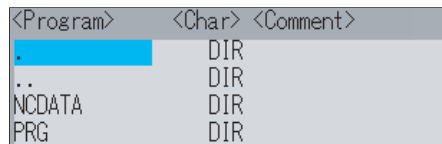

(5) Move the cursor to directory to be selected, and fix.
[↑], [↓] [INPUT]



The selected directory appears in the data setting column. The contents of the selected directory appear in the list.

Repeat this operation until the target directory is reached. When the target directory is reached, press the key and quit the mode for inputting the directory.

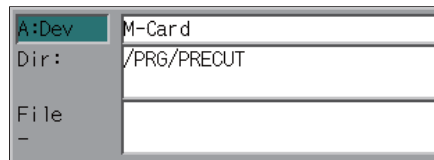

(Note) Refer to next page "Selecting a device file other than the NC memory (When simultaneously selecting the directory and file name.)" procedure (3) or later for method of file designation.

Selecting a device file other than the NC memory (When simultaneously selecting the directory and file name.)

(1) Press the menu [Device select] .

(2) Select a device.



The device name appears. The root directory is selected as the default.

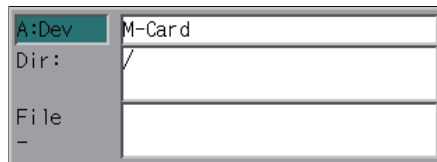

(3) Press the menu [File name]

<When inputting the file name from the input area>

(4) Input the file name
10013.PRG [INPUT]

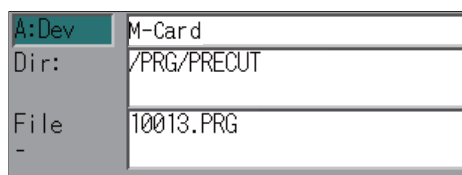

<When selecting the file name from the list>

(4) Press the menu [From list].



The cursor appears in the list.

<Program>	<Char>	<Comment>
.	DIR	
..	DIR	
10011.PRG	521 Oct 02 13:18 2002	
10012.PRG	141 Oct 02 13:19 2002	
10013.PRG	102 Oct 02 13:19 2002	
10014.PRG	163 Oct 02 13:20 2002	
10015.PRG	90 Oct 02 13:21 2002	

(5) Move the cursor to directory and file name to be selected, and fix.
[↑], [↓] [INPUT]

This operation is repeated until the cursor reaches the file. When only the directory is selected and

key is pressed, select the file name separately.

(6) Press the [INPUT] key.



The selected file name appears.

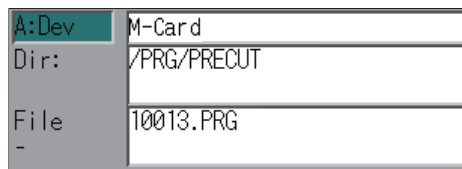

Canceling the input mode

- (1) Press the [Device Select] , [Dir] or [File name]. ➡ The submenu appears.

To cancel the data input at this time, press the  key.

- (2) Press the  key. ➡ The details in the input area are erased, and the main menu appears.

6.2.3 Transferring a File

Operating method

- | | | | |
|-----|---|---|---|
| (1) | Press the menu [Area change] , and select file setting column A. | | |
| (2) | Designate the transfer origin device, directory and file name. | ➔ | The designated file appears. Multiple files can be designated in the file setting column A. Designate the first and last file name of the target range. A wildcard "*" can be designated for the file name. |
| (3) | Press the menu [Area change] , and select file setting column B. | | |
| (4) | Designate the transfer destination device, directory and file name. | ➔ | The designated file appears. |
| (5) | Press the menu [Trnsfr A ->B]. | ➔ | A message appears to confirm the transfer. |
| (6) | Press [Y] or [INPUT]. | ➔ | The file transfer starts. The data being transferred appears in the input data display column. A message appears when the transfer is completed. |

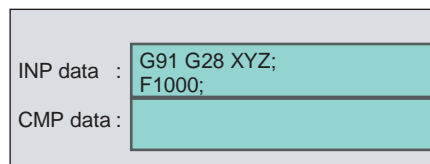

CAUTION

 " ; ", "EOB", "%", and "EOR" are symbols used for explanation. The actual codes for ISO are "CR, LF" ("LF") and "%". The programs created on the Edit screen are stored in the NC memory in a "CR, LF" format, however, the programs created with external devices such as the FD or RS-232C may be stored in an "LF" format. The actual codes for EIA are "EOB (End of Block)" and "EOR (End of Record)".

 To prevent the influence of data loss and data transformation over the line, always carry out data comparison after transferring a machining program.

Notes

(1) Notes related to transferring in general

- (a) Depending on the type of file, some data cannot be transferred during automatic operation. Do not transfer during automatic operation.
- (b) When the capacity of the transfer destination is reached during file transfer, only the data transferred up to that point is registered as a file, and an error will result.
- (c) During input to the NC memory or comparison, if the file format size on the NC memory side differs from the other side file format size (when the maximum number of registrations differs between the NC memory and the other side), processing is carried out matched to the smaller size.
 (Ex. 1) If a format size of 200 files is input for a format size of 1000 NC files, 200 files are registered.
 (Ex. 2) If a format size of 1000 files is input for a format size of 200 NC files, the files up to the 200th file are registered and an error message appears. (The remaining files are not registered.)

(2) Notes when transferring machining program files

- (a) For the serial, always set feed (Null) at both ends of the "EOR" code at the head and end. If "EOB" etc., is directly after "EOR", the operation may not execute normally due to the input buffer influence during the next input operation.
- (b) The transfer speed is slower if there are many registrations.
- (c) The size of one block of the machining program should be 250 characters or less.
- (d) The characters that can be used for the file name and directory path are 1-byte number, 1-byte capital alphabetical letters, and 1-byte symbols recognized by the system.
 Note that the following characters cannot be used.
 |, /, :, ", * , ? , " , < , > , a to z (small letters), Space
 Up to 32 characters are allowed for the file name to create in or transfer to NC memory.
- (e) If the file whose name includes lower case alphabet is transferred to NC memory, the lower case letter will be converted into the capital letter.
- (f) When using tape, carry out parity V adjustment to improve the reliability of the tape format. Then use with the input/output parameter "Parity V" validated.
- (g) When the machine tool builder macro and fixed cycle program are input to NC memory, change the program type with the parameter "#1166 fixpro". Also, set in the Input/Output screen as follows.
 Device: Memory, Directory: Program
- (h) Transferring or verifying the multiple files between the external device connected serially and that other than the serial connection.
- (i) With machining program created before the MELDAS500 Series, "EOB" is registered as "LF". However, when these programs are stored in the E70 Series NC memory, "EOB" will be converted to "CR LF", and the number of characters will increase. Thus, when all of the machining programs output from an MELDAS500 Series or earlier NC, having the same specifications as the maximum memory capacity, are stored in the E70 Series NC memory, the memory capacity may be exceeded.
- (j) When the file to be transferred (input) is running or in "program restarting" mode, "program checking", the operation message "Executing automatic operation" or "Program restarting" or "Program checking" is displayed and file will not be transferred (input).
- (k) If the file to be transferred (input) is being edited in the custom screen, the operation message "Can't write into being edited file" appears and may not be transferred (input).
- (l) When "#8936 Delete leading 0" is set to "1", the file consisting only of numerical figures will be transferred with the "0" at the head deleted. Refer to "4.5.16 Leading Zero" for details.
- (m) The transfer range from the external device other than serial to NC memory will change depending on the value set in the user parameter "#19006 EOR Disable".
 - When the user parameter "#19006 EOR Disable" is set to "0", the head line will not be transferred. Up to "%" in the second line onward will be transferred, and data after "%" will not be transferred. If there is no "%", all data will be transferred.
 - When the user parameter "#19006 EOR Disable" is set to "1", all file contents will be transferred.

(3) Notes when transferring tool offset data files

- (a) If an error occurs during offset data transfer, an error message appears on the screen, and the transfer operation is interrupted.
- (b) Tool offset data file cannot be transferred from the serial to the memory.

(4) Notes when transferring parameter files

- (a) In the same manner as when setting in the Parameter screen, there are parameters validated immediately after input, and parameters validated after a restart. Restart when a parameter file has been transferred to the NC memory.
- (b) When a parameter file is transferred to the NC memory, the setting value of the input/output parameters is also changed. Before transferring next time, set the input/output parameters again.

(5) Notes when transferring common variable data files

- (a) If the variable value is 100000 or more or less than 0.0001 when transferring common variable data, it is expressed with an exponential expression.

(6) Notes when transferring tool life data files

- (a) When tool life data is output from the NC memory, the file information is inserted at the first and last of the file.
First file information: Number of registered tools (P No.) and the maximum number of possible registrations (T No.)
Last file information: Finish code

(7) Notes when transferring sampling data file

- (a) When the output form is set as 8-digit hexadecimal number and the parameter "#1004 ctrlunit" is set to "E (1nm)", accurate data can be output just within 1m.
When the output data length exceeds 1m, lower 32 bits of the sampling data will be output.

(8) Notes when transferring workpiece offset data files

- (a) Tool offset data file cannot be transferred from the serial to the memory.

6.2.4 Comparing Files (Compare)

Operation method

- (1) Press the menu [Area change] , and select file setting column A.
- (2) Designate the device, directory and file name to be compared. ➡ The designated file name appears.
- (3) Press the menu [Area change] , and select file setting column B.
- (4) Designate the other side device, directory and file name to be compared. ➡ The designated file name appears.
- (5) Press the menu [Compare A:B]. ➡ The file comparison starts. The data being compared appears in the comparison data display column. A message appears when the comparison is completed. If a comparison error occurs, the block with the error is displayed in the comparison data display column on the screen.

```

INP data: (MAIN);G28XYZ;G00X10.;N1X20.
          ;X30.;X40.;N2X50.;M98P102H1;
CMP data: (MAIN);G28XYZ;G00X10.;N1X20.
          ;X30.;X40.;N2X50.;M98P103H1;
    
```

- (Note 1) Files that can be compared are text files only.
Correct outcome will not be obtained through binary file comparison.
- (Note 2) "0" at the head of the file name will not be deleted when checking the individual file which consists of one program in one file even "#8936 Delete leading 0" is set to "1". Designating the file name is required.
However, "0" at the head of the name will be deleted and checked for the serial/batch file.
- (Note 3) When transferring and comparing the machining program, if the value of the user parameter "#19006 EOR Disable" between the external devices other than between NC memory and serial differs, a comparison error may occur.

6.2.5 Erasing a File

Erasing a file [Erase A]

- (1) Press the menu [Area change] , and select file setting column A.
- (2) Designate the device, directory and file name to be erased. ➡ The designated file appears.
- (3) Press the menu [Erase A]. ➡ A message to confirm the erasing appears.
- (4) Press [Y] or [INPUT]. ➡ The file is erased.A message appears when the erasing is completed.The number of programs registered, number of memory characters and remainder reappear. Press the [List update] menu to update the list.

(Note1) If the file to be erased is running or in "program restarting" mode, the operation message "Executing automatic operation" or "Program restarting" is displayed, and the file will not be erased.

(Note 2) If the file to be erased is being edited in the custom screen, an operation message "Can't erase designated file", it may not be deleted.

Erasing a file Erase B

The operations are the same as method "Erasing a file [Erase A] " above. Designate the target device, directory and file name in the file setting column B, and press the menu [Erase B].

6.2.6 Changing a File Name (Rename)

Operation method

- (1) Press the menu [Area change] , and select file setting column A.
- (2) Designate the original device, directory and file name. ➡ The designated file name appears.
- (3) Press the menu [Area change] , and select file setting column B.
- (4) Designate the new device, directory and file name. ➡ The designated new file name appears.
- (5) Press the menu [Rename A -> B].
- (6) Press [Y] or [INPUT]. ➡ Renaming of the file starts.A message appears when the renaming is completed.

(Note 1) Select the same device for original and new devices.

(Note 2) If the file to be renamed is running or in "program restarting" mode, the operation message "Executing automatic operation" or "Program restarting" is displayed, and the name will not be changed.

(Note 3) If the file to be renamed is being edited in the custom screen, the operation message "Can't rename designated file" appears and may not be changed.

(Note 4) If a file that does not exist is designated for the original file, or if an existing file name is designated for the new file selection, an error occurs, and the name is not changed.

6.2.7 Creating a Directory

Operation method

- | | | | |
|-----|---|---|--|
| (1) | Press the menu [Area change], and select file setting column A. | | |
| (2) | Designate the device. | ➡ | The designated details appear. The devices that can create a directory are Memory card and USB memory. |
| (3) | Designate the directory where the new directory is to be created. | ➡ | The designated details appear. |
| (4) | Set the new directory in file setting column A. | ➡ | The designated details appear. |
| (5) | Press the menu [Dir create]. | ➡ | The designated directory is created. |

The directory can also be created in file setting area B.

6.2.8 Merging a File

Operation method

- (1) Press the menu [Area change] , and select the file setting column A.
- (2) Designate the merge destination device, directory and file name. ➡ The designated file name appears.
- (3) Press the menu [Area change], and select the file setting column B.
- (4) Designate the merge origin device, directory and file name. ➡ The designated file name appears.
- (5) Press the menu [Merge B ->A] . ➡ A message confirming the merge appears.
- (6) Press [Y] or [INPUT] . ➡ The file merge starts. The data being merged will appear in the Input Data display column. A message appears when the merge is completed.

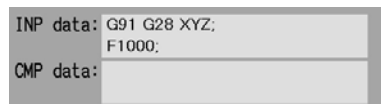

The details of the file in file setting column A will be as follows when the merge is completed.



<pre>(FILE A) G28 XYZ; G90 F800; G00 X100. Y100.; (FILE B) G91 G28 XYZ; F1000; G01 X200. Y200.; M02; %</pre>	<p>Details of file in file setting column A before merge.</p> <p>Details of file in file setting column B before merge.</p>
--	---

The details of the file in file setting column B do not change.

- (Note 1) If the merge destination file (file in file setting column A) is running or in "program restarting" mode, the operation message "Executing automatic operation" or "Program restarting" is displayed, and the files will not be merged.
- (Note 2) If the merge destination file (file in file setting column A) is being edited in the custom screen, the operation message "Can't write into being edited file" appears and may not be merged.
- (Note 3) When the user parameter "#19006 EOR Disable" is set to "1", a file is merged as it is. But the terminal character of the merge destination file (file in file setting column A) is "%", a line feed code is added and then merged.
- (Note 4) The devices that can be merged are the memory, memory card and USB memory.

6.2.9 Formatting an External Device

Operation method (Formatting a memory card)

- (1) Press the menu [MemCrd format].  A message confirming the formatting appears.
- (2) Press [Y] or [INPUT].  The memory card is formatted. A message appears when the formatting is completed.

(Note 1) The memory card is formatted with FAT16.

(Note 2) The volume label is set when the memory card is formatted.

Operation method (Formatting a USB memory)

First, press [USB format]. Refer to "Formatting a memory card" for more details.

(Note 1) USB memory is formatted with FAT16.

(Note 2) Only the DS formatted with FAT16 can be used.

6.2.10 List of File Names

There is a directory for each type of data in the NC memory.

Each directory and file name (fixed) in the NC memory is shown below.

Do not change the extensions (.XXX) when storing in a device other than the NC memory.

Data type	NC memory directory path	Fixed file name
Machining program	/PRG/USER	(Program No.)
Fixed cycle program	/PRG/FIX	(Program No.)
Machine tool builder macro	/PRG/MMACRO	(Program No.)
User macro	/PRG/UMACRO	(Program No.)
Parameters Parameters [User, machine] (Text format)	/PRM	ALL.PRM
PLC program	/LAD	USERPLC.LAD
NC data Tool compensation amount data Tool life management data Tool management data Common variable data SRAM data Workpiece offset data Option file	/DAT	TOOL.OFS TLIFE.TLF TOOLMNG.OFS COMMON.VAR SRAM.BIN WORK.OFS OPTION-ADD.OPT
System configuration data	/DGN	ASSEMBLY.INF
Backup file	/APLC	APLC.BIN
	/CUSTOM	CUSTOM.BIN
Decryption code	/RLS	PASSCODE.DAT

Data format (Parameter)

Parameter data format is as follows.

Address	Definition	Details
N	Parameter No.	The parameter No. is shown with the value following N.
A	Axis No.	For axis data, the axis No. is shown with the value following A. The first axis will be A1.
T	Part system No.	For data per part system, the part system No. is shown with the value following T. (\$1: T1, PLC axis: T5) (The E70 Series is one-part system control.)
C	Spindle No.	For spindle data, spindle No. is displayed with a numerical value following C. Thus, 1st spindle is displayed as C1.
K	Split data No.	For the parameter with which data is split and set, each split data is displayed. (Ex. IP address)
P	Parameter data	The parameter data is shown with the value following P.

The following types of data format are used according to parameter type and display method.
(The address order in one block must use the following format.)

(1) Common parameter (One data item per one # No.)

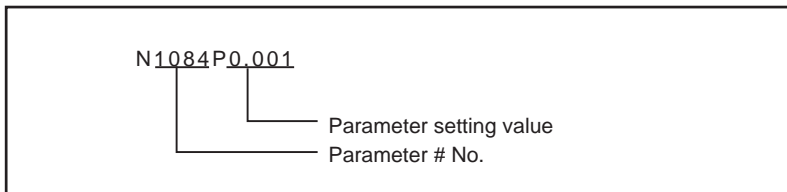

(a) The output parameter setting value is the same format as the screen display.

(2) Axis parameter

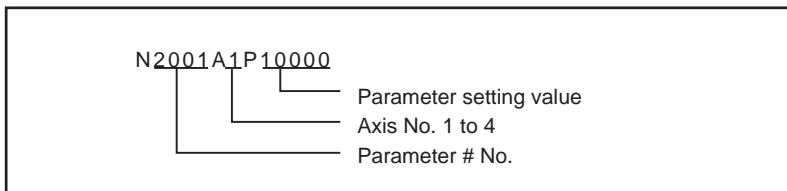

(a) When multiple axes are displayed on one screen

The parameter data for the screen in which multiple axes are displayed on one screen is output per axis.

[Output example]

```

:
N2001A1P120000
N2002A1P4000
N2003A1P21
:
N2001A2P12000
N2002A2P4000
N2003A2P21
:
    
```

} 1st axis data

} 2nd axis data

(3) Part system parameter

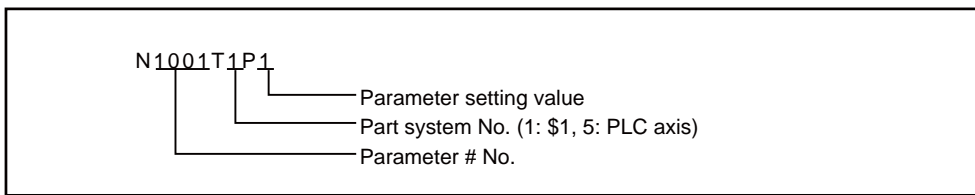

(The E70 Series is one-part system control.)

(a) The parameter data for the screen in which parameters per part system are displayed on one screen is output as follows.

[Output example]

:

N1001T1P1

N1001T2P0

N1001T5P0

N1002T1P2

N1002T2P0

N1002T5P0

:

(b) If parameters are displayed per part system upon switch of the part system (when key is pressed), the parameter data is output per part system.

[Output example]

:

N8001T1P99

N8002T1P0

N8003T1P10000

:

N8001T2P0

N8002T2P0

N8003T2P0

:

(4) Spindle parameter

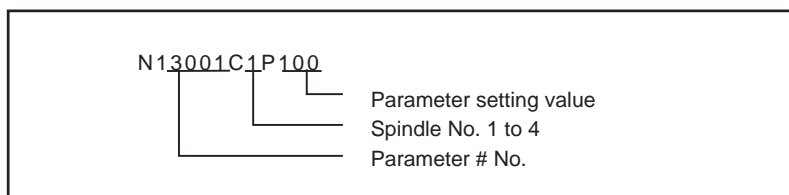

(a) When multiple spindles are displayed in one screen

The parameter setting value for the screen in which multiple spindles parameters are displayed in one screen is output per spindle.

[Output example]

```

:
N13001C1P100
N13002C1P100
N13003C1P15
} 1st spindle data
:
N13001C2P100
N13002C2P100
N13003C2P15
} 2nd spindle data
:
    
```

(5) IP address

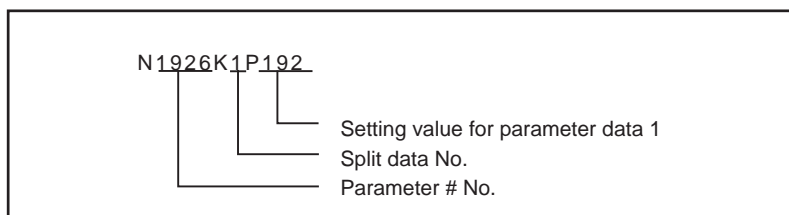

[Output example]

(Example) When "#1926 Global IP address" setting value is "192.168.200.1"

```

:
N1926K1P192
N1926K2P168
N1926K3P200
N1926K4P1
:
    
```

Data format (Tool compensation amount data)

(1) M type

Tool compensation amount data format is as follows.

Address	Definition	Details
G	-	Fixed to G10.
L	Type	L10 for tool compensation memory I. See below for tool compensation memory II. L10: Tool length shape compensation L11: Tool length wear compensation L12: Tool radius shape compensation L13: Tool radius wear compensation
P	Compensation No.	The compensation No. is shown with the value following P.
R	Compensation amount	The compensation No. is shown with the value following R.

[Output example]

```
%
$1
G10L10P1R0.000
G10L10P2R0.000
:
$2
G10L10P1R0.000
G10L10P2R0.000
:
%
```

(2) L type

Tool compensation amount data format is as follows.

Address	Definition	Details
G	-	Fixed to G10.
L	Type	L10 for tool length compensation input. L11 for tool nose wear compensation input.
P	Compensation No.	The compensation No. is shown with the value following P.
X	X axis compensation amount (Absolute)	The X axis compensation amount data is shown with the value following X. (Absolute)
U	X axis compensation amount (Incremental)	The X axis compensation amount data is shown with the value following U. (Incremental)
Z	Y axis compensation amount (Absolute)	The Y axis compensation amount data is shown with the value following Z. (Absolute)
W	Y axis compensation amount (Incremental)	The Y axis compensation amount data is shown with the value following W. (Incremental)
R	Nose R compensation amount (Absolute)	The nose R compensation amount data is shown with the value following R. (Absolute)
C	Nose R compensation amount (Incremental)	The nose R compensation amount data is shown with the value following C. (Incremental)
Q	Hypothetical tool nose point	The hypothetical tool nose point is shown with the value following Q.

[Output example]

```
%
G10L10P1X0.000Z0.000R1.000Q3
G10L11P1X0.000Z0.000R0.000Q3
G10L10P2X0.000Z0.000R1.000Q2
:
G10L11P80X0.000Z0.000R0.000Q0
%
```

Data format (Tool life management data)

(1) M type

Tool life management data format is as follows.

Address	Definition	Details
G	Group No.	The group No. for tool life management is shown with the value following G.
D	Tool no.	The tool No. is shown with the value following D.
S	Status	The tool status is shown with the value following S.
M	Method	The tool life management method is shown with the value following M.
L	Length compensation	The length compensation data is shown with the value following L.
R	Radius compensation	The radius compensation data is shown with the value following R.
B	AUX.	The auxiliary data is shown with the value following B.
E	Service lifetime	The service lifetime is shown with the value following E.
P	Used time	The used time is shown with the value following P.

[Output example]

```
%
LIFEDM()
$1
G100 D1000 S1 M101010 L100 R100 B11 E0 P0
G200 D2000 S2 M000000 L200 R200 B22 E0 P0
G300 D3000 S3 M201020 L300 R300 B33 E0 P0
:
G999999 D9999 S1 M202020 L999 R999 B99 E0 P0
%
```

(2) L type

(a) Tool life management I

Tool life management I format is as follows.

Address	Definition	Details
N	Tool No.	The tool No. is shown with the value following N.
P	Time-used	The time-used is shown with the value following P.
E	Time-max	The time-max is shown with the value following E.
Q	Count-used	The count-used is shown with the value following Q.
F	Count-max	The count-max is shown with the value following F.
S	Status	The status of tool life management is shown with the value following S.
B	AUX.	The auxiliary data is shown with the value following B.

[Output example]

```
%
LIFEL1( TOOL LIFE DATA)
$1
N1 P12.34.56 E45.56 Q6 F7 S1 B0
N2 P2.3.4 E5.6 Q7 F8 S1 B1
N3 P99.59.59 E99.59 Q9999 F9999 S2 B99
N4 P0.0.0 E0.0 Q0 F0 S0 B0
:
N80 P0.0.0 E0.0 Q0 F0 S0 B0
%
```

(b) Tool life management II

Tool life management II format is as follows.

Address	Definition	Details
G	Group No.	The group No. for tool life management is shown with the value following G.
M	Method	The tool life management method is shown with the value following M. 0: Life management is carried out using the time of cutting feed execution. 1: Life management is carried out using the number of usages. Counting the number of usages is executed when changing from rapid traverse command (G00, etc.) to cutting feed command (G01, G02, G03, etc.). Note that if rapid traverse command or cutting feed command that does not involve any movement is executed, usage will not be counted.
E/F	Service life	The life data (service lifetime) is shown with the value following E. The life data (service life count) is shown with the value following F. (Note 1) When the combination of the setting of tool life management method and address is illegal, error occurs at data input. (Note 2) The USED data will be incremented when the LIFE data is "0", but no judgment if the service life is reached will be made.

Address	Definition	Details
A/B	Remaining life	[Tool life prediction function valid (#1277 ext13 bit1 is "1")]The tool life prediction data (remaining lifetime) is shown with the value following A.The tool life prediction data (remaining life count) is shown with the value following B. (Note 1) When the value greater than the tool life data is set, tool life prediction signal is not output. (Note 2) When the combination of the setting of tool life management method and address is illegal, error occurs at data input. [Tool life prediction function invalid (#1277 ext13 bit1 is "0")]A and B are not used.
D	Tool No.	The tool No. is shown with the value following D.
H	Compensation No.	The compensation No. is shown with the value following H.
P/Q	Used	The used data (used time) is shown with the value following P or Q.The used data (used count) is shown with the value following P or Q. (Note 1) When the combination of the setting of tool life management method and address is illegal, error occurs at data input.
S	Status	The tool status is shown with the value following S. 0: Not used tool 1: Current tool (tool being used) 2: Normal life-reached tool 3: Tool skip tool

[Output example]

```
%
LIFEL2( TOOL LIFE DATA)
$1
G100 M0 E1000 A50 D123456 H1 P321 S1
G100 M0 E1000 A50 D888888 H2 P0 S0
G111 M1 F2000 B80 D777777 H20 Q2000 S2
G1234 M0 E1000 A50 D123 H30 P100 S1
G9999 M1 F999999 B9 D999999 H80 Q999999 S2
%
```

Data format (Common variable data)

Common variable data format is as follows.

Address	Definition	Details
N	Variable No.	The common variable # No. is shown with the value following N.
T	Part system No.	For data per part system, the part system No. is shown with the value following T.(\$1: T1, PLC axis: T5) (The E70 Series is one-part system control.)
P	Common variable data	The common variable data is shown with the value following P.An exponential is displayed when 7 digits are set in the integer section and 5 digits or more are set in the decimal section. (Example) 1234567 R 1.2346E+006, 0.00001 R 1.0000E-005

[Output example]

```
%
COMN()
N100T1P123.0000
N101T1P1.0000E7
:
:
%
```

Data format (System configuration data)

System configuration data format is as follows.

Contents of the data are same as that of displayed in the system configuration screen and drive monitor screen of the diagnosis screen.

[COMMON] FILE=ASSEMBLY DATE=04.11.01 TIME=15:30:00 NC_TYPE=MITSUBISHI CNC E70L	
	Data & time of system configuration data output
	NC type
(1) NC unit configuration	Same as "H/W config" screen
(2) H/W configuration	Same as "H/W config" screen
(3) Servo drive unit information	Same as "Servo unit" screen
(4) Spindle drive unit information	Same as "Spindle unit" screen
(5) Power supply unit information	Same as "Power unit" screen
(6) S/W configuration	Same as "S/W config" screen
(7) Ladder configuration	Same as "Ladder config" screen
[F_END]	

[Output example]

[COMMON] FILE=ASSEMBLY DATE=04.11.01 TIME=15:30:00 NC_TYPE=MITSUBISHI CNC E70L	Tag described at the top of the file Header information of the file (file type) File output date File output time NC type and Lathe(L)/Machining center(M)
[FILE] TYPE=NC_UNIT NC_NAME=FCA70P-2E UNIT_NAME=FCU7-MU558 NC_SN=M1234567890 [END]	Tag described at the top of the data Data type (NC unit configuration) Describe items and data Tag described at the end of the data
[FILE] TYPE=HARDWARE [DATA1] HW_NAME=HN768 REVISION=A [DATA2] : [DATA _n] HW_NAME=HN441 REVISION=A [END] :	Data type (H/W configuration) Repetitive data No. tag (1st) Describe items and data Repetitive data No. tag (2nd) Repetitive data No. tag (n-th) Describe items and data
[FILE] : [END] [F_END]	Tag indicating file end

6.2.11 Edit Lock B and C

This function prohibits editing, erasing, etc., of the machining programs B and C, and protects the machining programs in NC memory.

Machining program	Edit lock B	Edit lock C
A 1 to 7999 10000 to 99999999	---	---
B(user standard subprogram) 8000 to 8999	Editing prohibited	---
C(machine tool builder customprogram) 9000 to 9999	Editing prohibited	Editing prohibited

The operations below in the Edit MDI and the Input/Output screens are influenced by the edit lock setting.

An error will result if operations that are not possible are attempted.

When the edit lock is valid, processing is executed (except the edit lock target program) by the input/output function.

○ : Operation possible × : Operation not possible

Screen	Operation	Edit lock B			Edit lock C		
		Machining program			Machining program		
		A	B	C	A	B	C
Edit	Search	○	○	×	○	○	×
	Edit	○	×	×	○	○	×
	MDI registration	○	×	×	○	○	×
Input/Output	Transfer	○	×	×	○	○	×
	Compare	○	×	×	○	○	×
	Copy	○	×	×	○	○	×
	Merge	○	×	×	○	○	×
	Rename	○	×	×	○	○	×
	Erase	○	×	×	○	○	×
Monitor	Buffer correction	○	×	×	○	○	×

(Note 1) When multiple serial files or a wildcard (*) is designated for input/output function, programs except subject to edit lock will be processed.

(Note 2) When a multiple programs are input to the memory without designating the file name like serial input or program batch input, the message "Edit lock B" or "Edit lock C" will be displayed and the input will be interrupted if the program which is subject to edit lock is detected.

6.2.12 Data Protect Keys

The data protect keys can be used to prohibit data setting and erasure. The following three keys are available. (Their names differ according to the machine tool builder. For further details, refer to the instruction manual issued by the machine tool builder.)

- (1) KEY1:Provides general protection for tool data and protection of the coordinate system preset using the origin set.
- (2) KEY2:Protects user parameters and common variables.
- (3) KEY3:Protects the machining program.

Data settings and deletion is stopped if any of the data protection keys is OFF.

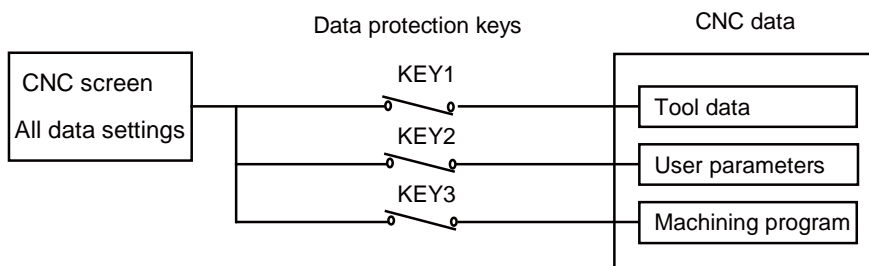

Tool data protection (KEY 1)

The operations listed in the table below are prohibited when KEY 1 is OFF.

<Data protected by KEY1 >

No.	Operation	Screen
1	Origin set	Monitor
2	Tool compensation amount setting/erasing	Tool compensation amnt, Tool measure
3	Tool registration data setting/erasing	Tool registration
4	Tool life data setting/erasing	Tool life
5	Workpiece coordinate offset amount setting/erasing	Coord offset, Workpiece measure, Rotate meas
6	Tool offset data input/output	Input/Output
7	Tool compensation amount input/output	Input/Output
8	Tool registration data input/output	Input/Output
9	Tool life data input/output	Input/Output
10	Workpiece coordinate offset amount input/output	Input/Output
11	Tool management data input/output	Input/Output

(Note) If setting of data in the screens shown in No. 2 to 5 is attempted when the KEY1 is OFF, the message "Data protect" appears. If origin set is attempted on the Position display1 screen and the [INPUT] key is pressed, the origin set is not executed, and the message "Origin set not possible" appears. If the operations shown in No. 6 to 10 are attempted and the [INPUT] key is pressed, the message "Data protect" appears, and the input and output are disabled.

User parameter, common variable protection (KEY 2)

The operations listed in the table below are prohibited when KEY 2 is OFF.

<Data protected by KEY 2>

No.	Operation	Screen
1	Control parameter ON/OFF	Setup/User/Control param
2	Axis parameter setting	Setup/User/Axis param
3	Operation parameter setting	Setup/User/Operation param
4	Machining parameter setting	Setup/User/Process param, Rotate meas
5	Common variable setting	Monitr/Position display/Common variable
6	I/O basic parameter setting	Mainte/Parameter
7	Parameter input/output	Mainte/I/O
8	Common variable input/output	Mainte/I/O

(Note) If setting of data in the screens shown above is attempted when the KEY2 is OFF, the message "Data protect" appears. If the operations shown in No. 7 and 8 are attempted and the [INPUT] key is pressed, the message "Data protect" appears, and the input and output are disabled.

Machining program protection (KEY 3)

The operations listed in the table below are prohibited when KEY 3 is OFF.

<Data protected by KEY3>

No.	Operation	Screen
1	MDI data memory entry	MDI
2	Machining program editing	Edit
3	New program editing	Edit
4	Registered program comment setting	Edit
5	Machining program memory registration, compare, input/output	Input/Output
6	Machining program erasing (single, all)	Input/Output
7	Registered program comment setting	Input/Output
8	Machining program copy, marge, name change	Input/Output
9	Machining program buffer correction	Monitr

(Note) If editing or setting, etc., is attempted on the screens shown above when the KEY3 is OFF, the message "Data protect" appears.

6.2.13 Sharing Machining Data

Machining data can be send to/received from Anshin-net server in the call center.

Operation method

- | | | |
|-----|---|---|
| (1) | Use the menu [Area change] to select file setting column A. | |
| (2) | Designate the transfer source device, directory and file name. | ➡ The designated file appears. |
| (3) | Use the menu [Area change] to select file setting column B. | |
| (4) | Press the menu [Anshin net] to designate the transfer destination device and file name. | ➡ "Anshin-net server" is displayed as device name. The file name, unless specified, is as same as the name of the originally transferred file. Only numbers within 10 characters can be used for a file name. |
| (5) | Press the menu [Transfr A → B] . | ➡ A message appears to confirm the transmission of machining data. |
| (6) | Press the [Y] or [INPUT] key. | ➡ Transmission of machining data starts. A message appears upon the completion of transmission. |

(Note 1) Neither HD operation nor memory card operation can be performed during file transmission from HD.

(Note 2) Only one file can be saved on Anshin-net server. The file previously exists on the Anshin-net server is overwritten.

(Note 3) Anshin-net icon appears in the upper middle of the screen during Anshin-net communications.

(Note 4) When Anshin-net server is specified as device name, the directory button is displayed in gray and cannot be selected.

Receiving machining data from Anshin-net server

- (1) Use the menu [Area change] to select file setting column A.
- (2) Press the menu [Anshin net] to designate the transfer source device and file name. ➡ "Anshin-net server" as device name and the designated file name are displayed.
- (3) Use the menu [Area change] to select file setting column B.
- (4) Designate the transfer destination device, directory and file name. ➡ The designated file appears.
- (5) Press the menu [Transfr A → B]. ➡ A message appears to confirm the reception of machining data. When the file name is not designated in the file setting column A, the message "File name not designated for dev A" appears to indicate the error.
- (6) Press the [Y] or [INPUT] key. ➡ The reception of machining data starts. A message appears upon the completion of reception.

(Note 1) When the same file name exists in the transfer destination device, an error occurs and the transfer cannot be executed.

(Note 2) Anshin-net icon appears in the upper middle of the screen during Anshin-net communications.

(Note 3) When Anshin-net server is specified as device name, the directory button is displayed in gray and cannot be selected.

Erasing machining data on Anshin-net server

- (1) Use the menu [Area change] to select file setting column A.
- (2) Press the menu [Anshin-net] to designate the file name to erase. ➡ "Anshin-net server", as device name, and the designated file name are displayed.
- (3) Press the menu [Erase A]. ➡ A message appears to confirm the erasing.
- (4) Press the [Y] or [INPUT] key. ➡ The file will be erased. A message appears upon the completion of erasing.

Canceling a warning from network service

- (1) Press the menu key [Warning cancel]. ➡ The warning message from network service is cleared.

(Note 1) A warning message from network service appears when any error occurs during communications.

(Note 2) NC reset can also clear the warning message from network service.

Notes

- (1) Transfer to/from Anshin-net server cannot be interrupted.
- (2) Only machining program, except fixed cycle and machine tool builder macro, can be transferred to Anshin-net server.
- (3) Data transfer between Anshin-net server and serial (RS232C) or Ethernet is not available.
- (4) The edit screen and the maintenance screen can share machining data. However, the machining data being transferred to/from either of the screens cannot be shared with the other screen.
- (5) Wildcard (*) cannot be used for the file name.
- (6) The capacity of machining program for transmission is restricted according to the settings of Anshin-net server.

6.2.14 The Batch Input/Output the Machining Program of NC Memory

One file which consists of two or more machining program can be transferred to NC memory by dividing the file. The machining programs united with one file can be transferred to the external device. The targets are the machining programs of the user.

Batch input and verify to NC memory

Example of "the external device -> NC memory" of machining program batch transfer

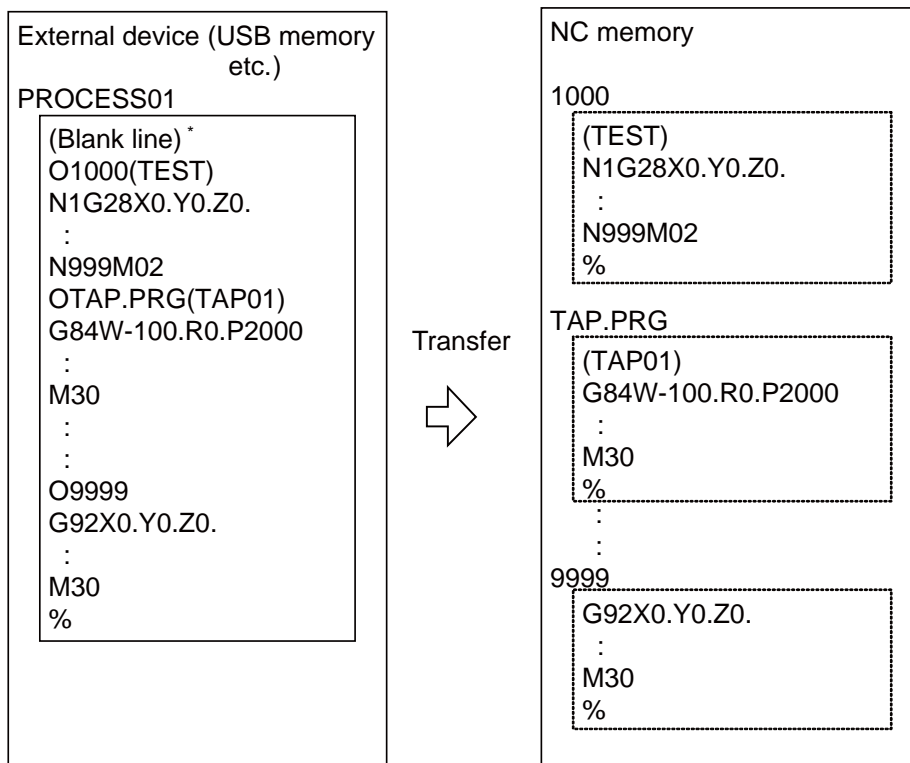

When the external device is serial, the top line is %.

When the transfer direction file name is designated, the top program name of transfer source can be omitted. ("O1000" can be omitted in above example.)

- (1) Press the menu [Area change] to select file setting column A.
- (2) Designate the transfer source device and directory. ➡ The designated device and directory appear.
- (3) Designate the file which consists of two or more machining programs. ➡ The designated file name appears.
- (4) Press the menu [Area change] to select file setting column B.
- (5) Designate the transfer direction device (memory). ➡ The designated device name (memory) appears.
- (6) Press the menu [Dir] - [Program all]. ➡ The "Program all" appears in the directory.
 When the file name is designated, only the top program of transfer source is stored in the designated file. For example of "Example of "the external device -> NC memory" of machining program batch transfer", when "TESTCUT" is designated as the transfer direction file name, the top program is transferred as not "1000" but "TESTCUT".
- (7) Press the menu Transfr [A → B] . ➡ The operation message "OK? (Y/N)" appears.
- (8) Press the [Y] or [INPUT] key. ➡ Transmission of machining data starts. Transmitting data is displayed in input data display column. The message "Transfer complete" appears upon the completion of transmission.
 When the same machining program already exists in transfer direction device, the operation message "Overwrite this file?(Y/N)" appears. The transferring the following program is continued by selecting [Y] or [N] key.
- (9) Press the menu [Compare A:B] key. ➡ The verification of the file starts. The verifying data is displayed. When the verification is completed, the operation message appears. When the verification error occurs, the error block is displayed in verification data display column and the operation message "Compare error. Compare next file?(Y/N)" appears.

- (Note 1) When programs are input in a batch to NC memory, always specify "Program batch" to NC memory directory as transfer direction. If "Program batch" is not specified, one file is transferred (No batch).
- (Note 2) When the program which is subject to edit lock exists in transfer source, the message "Edit lock B" or "Edit lock C" appears, and transfer is interrupted. When the program which is not subject to edit lock is transferred, delete the program which is subject to edit lock in transfer source. (Refer to "6.2.11 Edit Lock B and C".)
- (Note 3) When the machining program protection is valid (KEY3 is OFF), the program cannot be transferred/verified. (Refer to "6.2.13 Data Protect Keys".)

- (Note 4) The program during automatic operation, program restart or program checking cannot be overwritten. the operation message "Executing automatic operation", "Program restarting" or "Program checking" appears, and transfer is interrupted.
- (Note 5) If the transfer destination includes the file being edited in the custom screen, the operation message "Can't write into being edited file" appears and the transfer may be interrupted.
- (Note 6) The first line of the transfer source file is ignored.
- (Note 7) When the transfer source is serial, the program is similarly transferred even if direction of following case 1 and case 2 is set.

	Case 1	Case 2
Device name	Memory	Memory
Directory	Program batch	Program
File name	(Null or file designation)	(Null or file designation)

Batch output and verify from NC memory

Example of "NC memory -> the external device" of machining program batch transfer

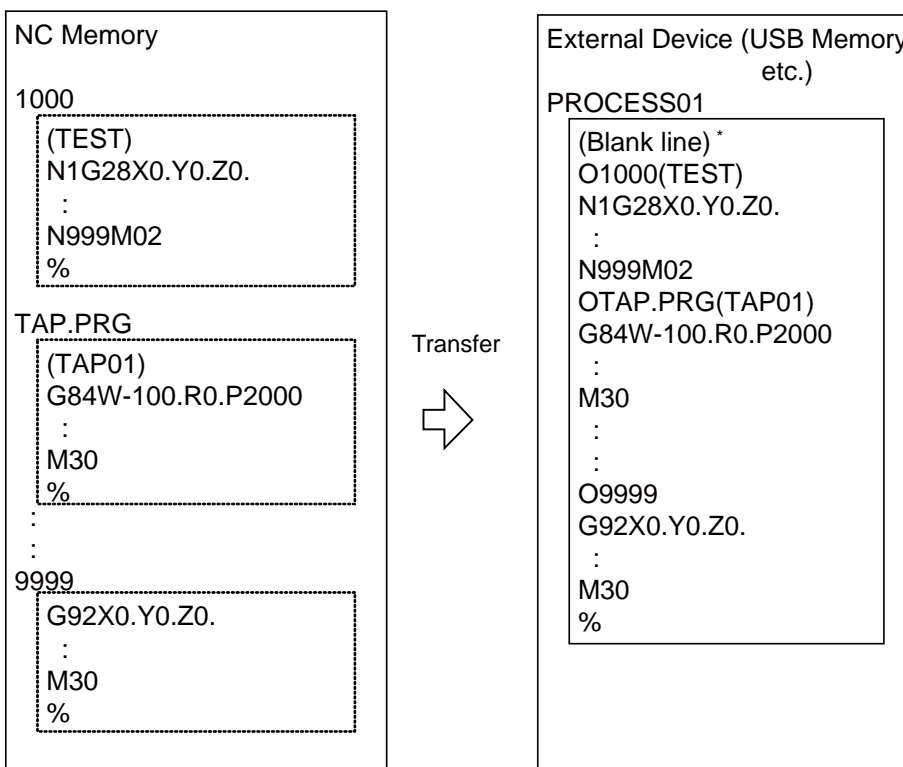

When the external device is serial, the top line is %.

6 Maintenance Screens

- (1) Press the menu [Area change] to select file setting column A.
- (2) Designate the transfer source device (memory). ➡ The designated device (memory) appears.
- (3) Press the menu [Dir] - [Program all] . ➡ The "Program all" appears in the directory.
Do not specify the file name. If the name is specified, an error will occur.
- (4) Press the menu [Area change] key to select file setting column B.
- (5) Designate the transfer direction device and directory. ➡ The designated device name and directory appear.
- (6) Designate the transfer direction file to input multiple machining programs. ➡ The designated file name appears.
When the file name is not designated, output to the file "ALL.PRG" of the designated directory.
- (7) Press the menu [Transfr A → B]. ➡ The operation message "OK? (Y/N)" appears.
- (8) Press the [Y] or [INPUT] key. ➡ Transmission of machining data starts. Transmitting data is displayed in input data display column.
When the same machining program already exists in transfer direction device, the operation message "Overwrite this file?(Y/N)" appears. The transferring the following program is continued by selecting [Y] or [N] key. ➡ The operation message "Transfer complete" appears upon the completion of transmission.
- (9) Press the menu [Compare A:B] key. ➡ The verification of the file starts. The verifying data is displayed. When the verification is completed, the message appears. When the verification error occurs, the error block is displayed in verification data display column and the operation message "Compare error. Compare next file?(Y/N)" appears.

- (Note 1) When programs are output in a batch from NC memory, always specify "Program batch" to NC memory directory as transfer source. If "Program batch" is not specified, the program is transferred by one program per one file.
- (Note 2) When the programs which are subject to edit lock exists in NC memory, those file is not transferred. (The files are transferred excluding those files.) The verification is executed excluding the programs which are subject to edit lock. (Refer to "6.2.11 Edit Lock B and C".)
- (Note 3) When the machining program protection is valid (KEY3 is OFF), the program cannot be transferred/verified. (Refer to "6.2.13 Data Protect Keys".)
- (Note 4) When the transfer direction is serial, the program is similarly transferred even if source of following case 1 and case 2 is set.

	Case 1	Case 2
Device name	Memory	Memory
Directory	Program batch	Program
File name	(Null)	* (Wild card)

Notes

- (1) When the machining program batch input/output function of NC memory is used, "(" cannot be used for the machining program name. It is recognized that the inside of ")" is a comment.
- (2) The file name of file which consists of two or more machining program can have up to 32 characters, including the extension as well as the machining program.
- (3) When the "Program batch" is designated to NC memory directory, it is not possible to delete, rename and merge files. When the files are deleted in a batch, use "Program" for directory, and a wild card (*) for file name.
- (4) Refer to Note of "6.2.3 Transferring a File" for other notes.

6.3 All Backup Screen

This screen is used to perform batch backups of NC memory data to an external device, and batch restoration of that data to the NC memory.

Data backed up by the automatic backup function can also be restored.

Data which has been automatically backed up can be selected only when the device set by the "#8919 Auto backup device" parameter setting is selected.

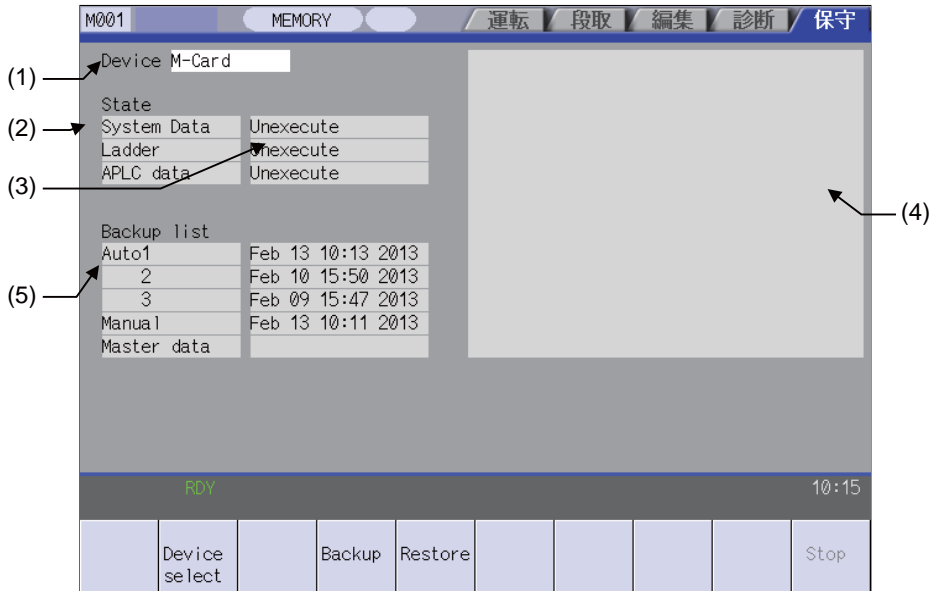

Display items

Display item	Details												
(1) Device name	This displays the selected device name.												
(2) Data name	This displays the data name being backed up/restored. System data, ladder, APLC data and custom data are displayed.												
(3) Execution status	This displays the processing execution status. Processing is executed in the system data, ladder, and APLC data order. (Note 1)												
(4) Warning message	This displays messages at the start and end of backup/restore processing.												
(5) Backup list	This displays the backup date list. This date is the system data time stamp.												
	<table border="1"> <thead> <tr> <th>Backup area</th> <th>Explanation</th> <th>Backup format</th> </tr> </thead> <tbody> <tr> <td>Auto 1 2 3</td> <td>Data that was automatically backed up. Display in the backup date descending order. The latest three generations of data are displayed.</td> <td>Auto</td> </tr> <tr> <td>Manual</td> <td>Data that was backed up on this screen.</td> <td>Manual</td> </tr> <tr> <td>Master data</td> <td>Data that was backed up on this screen. Generally, this is the factory settings data.</td> <td>Manual</td> </tr> </tbody> </table>	Backup area	Explanation	Backup format	Auto 1 2 3	Data that was automatically backed up. Display in the backup date descending order. The latest three generations of data are displayed.	Auto	Manual	Data that was backed up on this screen.	Manual	Master data	Data that was backed up on this screen. Generally, this is the factory settings data.	Manual
	Backup area	Explanation	Backup format										
Auto 1 2 3	Data that was automatically backed up. Display in the backup date descending order. The latest three generations of data are displayed.	Auto											
Manual	Data that was backed up on this screen.	Manual											
Master data	Data that was backed up on this screen. Generally, this is the factory settings data.	Manual											
The above data can be selected at restore processing. (Note 2)													

(Note 1) "APLC data" cannot be backed up/restored if the optional "APLC" is disabled.

(Note 2) The "Auto 1 to 3" data display when the device set by the "#8919 Auto backup device" parameter is selected.

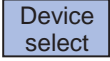
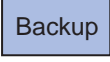
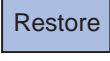
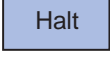

(Note 3) "Custom data" from other models can not be restore to E70. When restore is attempted, the status of "custom data" will remain "not executed" but the operation message "restore completed" will appear. Custom data that is backed up in E70 can be restored to other models.

Menus

Menu	Detail	Type	Reference
	This displays the sub-menu for "Device" selection.	C	
	This executes backup processing.	A	6.3.1 Performing a Backup Operation
	This executes restore processing.	A	6.3.2 Performing a Restore Operation
	This stops processing.	C	



6.3.1 Performing a Backup Operation

Operation methods

- (1) Press the menu [Backup].  The menu is highlighted. An operation message "Select directory to backup" appears.
- (2) Move the cursor to select the area. Press the [INPUT] key.  An operation message "OK? (Y/N)" appears. (Note) Auto 1 to 3 cannot be selected.
- (3) Press [Y] or [INPUT] key.  Backup operation begins. An operation message "Performing Backup" appears. When the backup is completed without error, an operation message "Backup complete" appears.

6.3.2 Performing a Restore Operation

Operation methods

- (1) Press the menu [Restore].  The menu is highlighted. An operation message "Select directory to restore" appears.
- (2) Move the cursor to select the file. Press the [INPUT] key.  An operation message "OK? (Y/N)" appears.
- (3) Press [Y] or [INPUT] key.  Restore operation begins. An operation message "Restoring" appears. When the restoration is completed without error, an operation message "Restore complete" appears.

6.4 System Setup Screen

The essential data required for the NC's initial startup is automatically set by inputting the minimum requirement item only on this screen.

This function allows setting data required to drive the motors (servomotors, spindle motor) to be specified quickly and easily, resulting in a faster initial startup of the tool machine.

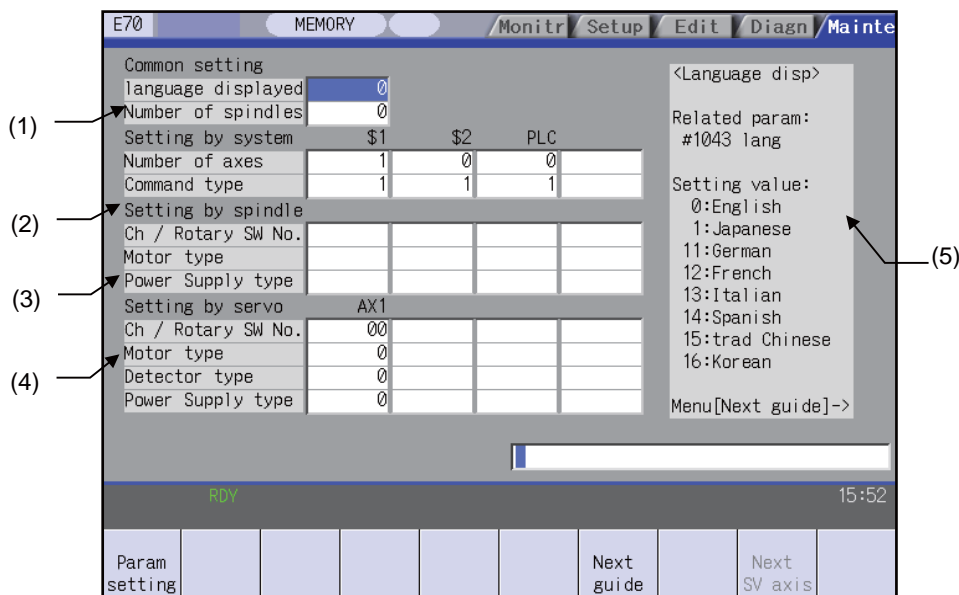

Display items

Display item	Details
(1) Common setting area	
Language displayed	Set the display language for system setup and after setup (after the power is turned ON again). This setting is registered at the "#1043 lang".
Number of spindles	Set the number of spindles connected to the NC. This setting is registered at the "#1039 spinno".
(2) Setting by system area (Note) The E70 is one-part system control. Set "0" for the 2nd part systems and later. A setting error occurs if "1" or greater value is set for them.	
Number of axes	Set numbers of control axes and PLC axes. This setting is registered at the "#1002 axisno".
Command type	Set the command type. This setting is registered at the "#1037 cmdtyp".

Display item	Details
(3) Setting by spindle area	
Ch / Rotary SW No.	Set the servo I/F connection channel and the rotary switch No. (2-digit value) for each spindle drive unit. This setting is registered at the "#3031 smcp_no". 1st digit: Servo I/F connection channel. 2nd digit: Rotary switch No.
Motor type	Set the motor types that are connected to each spindle. Input the values as indicated at the guidance display area. The input values are not converted to motor types.
Power Supply type	Set the power supply types that are connected to each spindle drive unit. Input the values as indicated at the guidance display area. The input values are then converted to, and display as, power supply types. If "0" is displayed, it means "No connection".
(4) Setting by servo area	
Ch / Rotary SW No.	Set the servo I/F connection channel and the rotary switch No. (2-digit value) for each servo drive unit. This setting is registered at the "#1021 mcp_no". 1st digit: Servo I/F connection channel. 2nd digit: Rotary switch No.
Motor type	Set the motor types that are connected to each servo axis. Input the values as indicated at the guidance display area. The input values are then converted to, and displayed as, motor types.
Detector type	Set the encoder types that are connected to each servomotor. Input the values as indicated at the guidance display area. The input values are then converted to, and displayed as, encoder types.
Power Supply type	Set the power supply types that are connected to each servo drive unit. Input the values as indicated at the guidance display area. The input values are then converted to, and displayed as, power supply types. If "0" is displayed, it means "No connection".
(5) Guidance display area	Indicate the setting content and setting range for the setting item where the cursor is positioned.

Menus

Menu	Details	Type	Reference
Param setting	This writes the parameters based on settings on system setup screen to NC system.	A	6.4.1 Writing Initial Parameters
Next guide	This displays the next page when guidance display content extends through multiple pages.	C	
Next SV axis	This displays the 5th axis and following in setting by servo area when the total number of axis in the part system exceeds 5.	C	

6.4.1 Writing Initial Parameters

Operation methods

- (1) Enter all the required settings on the system setup screen.

- (2) Press the menu[Param setting].
 - ➡ The menu is highlighted.
An operation message "Set up parameter? (Y/N)" appears.

- (3) Press the [Y] or [INPUT] key.
 - ➡ Parameter setting begins, and an operation message appears as follows.
"Initial parameter creating" → "Initial parameter transferring" → "Spindle initial parameter transferring" (This operation message is displayed only if a spindle parameter setting file exists.)
When parameter settings are completed, an operation message "Param set ended. Format NC memory? (Y/N)" appears.

- (4) Press the [Y] or [INPUT] key.
 - ➡ File formatting begins, and an operation message "Executing format" appears.
When file formatting is completed, an operation message "Format complete" appears.

- (Note 1) When the "data protect key 2" is enabled, an operation message "Data protect" appears, and processing is interrupted.
- (Note 2) In the automatic operation mode, an operation message "Executing automatic operation" appears, and processing is interrupted.
- (Note 3) If all the required settings have not been input on the system setup screen, an operation message "Setting error" appears, and processing is interrupted.
- (Note 4) Processing is interrupted if a key other than the [Y] or [INPUT] key is pressed, or if switching to another screen occurs. (Processing is interrupted even if switching to another screen occurs during data transfers.)
- (Note 5) The menu is displayed in gray during data transfers.
- (Note 6) When the inserted memory card contains the spindle parameter setting file (INITSP.PRM), the default parameters of "Setting by spindle" set on the screen are overwritten with those from the file.

6.5 Adjust S-analog Screen

The spindle analog output adjustment is carried out on this screen.

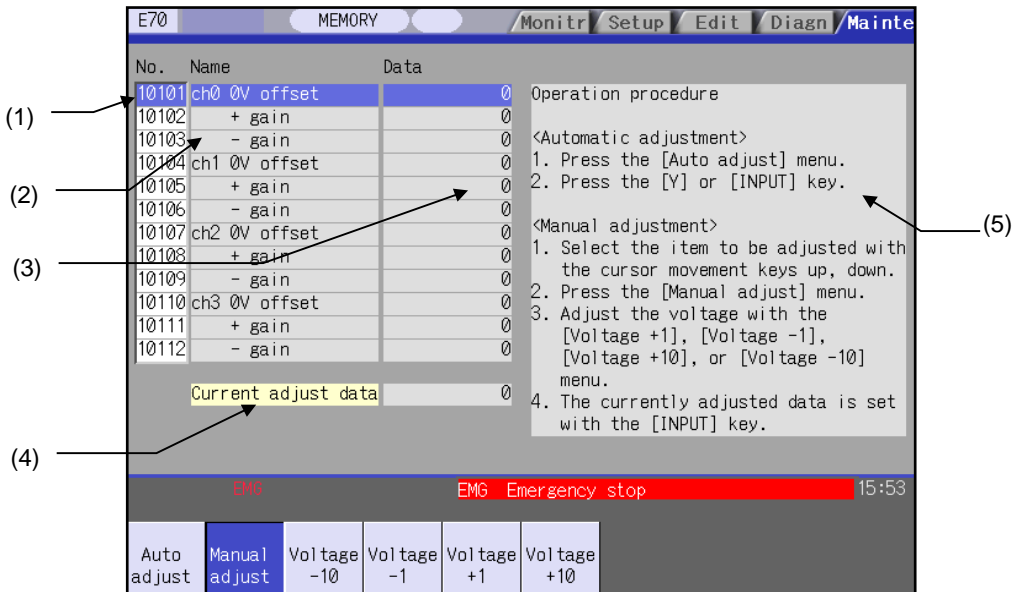

Display items

Display item	Details
(1) Parameter No.	For manual adjustments, this uses the [↑][↓] keys to move the cursor to the setting item to be adjusted. The cursor does not display during automatic adjustments.
(2) Adjustment item name	This displays the names of the spindle analog adjustment items.
(3) Adjustment data	This displays the setting data for each adjustment item.
(4) Current adjust data	This displays data which is being adjusted manually. (Display only during a manual adjustment.)
(5) Operation procedure	This displays the operation procedures for automatic and manual adjustments.



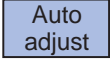
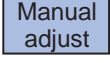
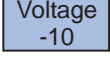
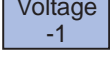
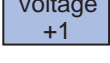
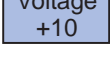

Menus

Menu	Details	Type	Reference
	This carries out automatic adjustment of the spindle analog output.	A	6.5.2 Performing Automatic Adjustments
	This carries out manual adjustment of the spindle analog output.	B	6.5.3 Performing Manual Adjustments
	This is used during manual adjustments to adjust downward in decrements of 10.	C	
	This is used during manual adjustments to adjust downward in decrements of 1.	C	
	This is used during manual adjustments to adjust upward in increments of 1.	C	
	This is used during manual adjustments to adjust upward in increments of 10.	C	

6.5.1 Adjustment Preparations

Operation methods

The PLC must be stopped when performing spindle analog output adjustments.

- (1) Press the function key [MAINTE].  The maintenance screen appears.
- (2) Press the menu [Psswd input].  The menu is highlighted.
- (3) Enter the machine tool builder password.  The menu highlighting is cleared.
- (4) Press the menu [PLC STOP].  The PLC is stopped.

6.5.2 Performing Automatic Adjustments

Automatic adjustment will execute "0V offset adjustment" and "+ gain adjustment" for the remote I/O analog outputs (max. 4ch) connected to the main unit. The - gain will be handled as the + gain.

Operation methods

- (1) Press the menu [Auto adjust].
 - ➔ The menu is highlighted.
An operation message "Execute? (Y/N)" appears.
The cursor display clears from the screen.

- (2) Press the[Y] or [INPUT] key.
 - ➔ Automatic adjustment begins, and an operation message "Auto adjust execution" appears.
The manual adjustment related menu is displayed in gray during the automatic adjustment, and manual adjustments are disabled.
Switching to other screens is also disabled at this time.
When the automatic adjustment is completed, an operation message "Auto adjust complete" appears.

6.5.3 Performing Manual Adjustments

Adjusting the ch0 0V offset

- (1) Use the [↑] [↓] keys to move the cursor to item #10101, then press the [Manual adjust] menu button.
 - ➔ The menu and the selected line are highlighted.
The current setting value is displayed at "Current adjust data".
A 0V analog voltage is output to ch0 at this time.

- (2) Monitor the analog voltage.
 - ➔ Adjust the 0V offset until the analog voltage is $0V \pm 3.5mV$.
The setting range -999 to 999.

- (3) <For plus-voltage>
 - Press the menu [Voltage +1] or [Voltage +10]
 - ➔ "Current adjust data" is adjusted downward in decrements of 1 each time the menu [Voltage +1] is pressed.
"Current adjust data" is adjusted downward in decrements of 10 each time the menu [Voltage +10] is pressed.

 - <For minus-voltage>
 - Press the menu [Voltage +1] or [Voltage +10].
 - ➔ "Current adjust data" is adjusted upward in increments of 1 each time the menu [Voltage +1] is pressed.
"Current adjust data" is adjusted upward in increments of 10 each time the menu [Voltage +10] is pressed.

 - "Current adjust data" range is -999 to 999.

- (4) Press the [INPUT] key.
 - ➔ "Current adjust data" is set as "ch0 0V offset", and the 0V offset result is enabled.
The menu [Manual adjust] highlighting is cleared.

Adjusting the ch0 + gain

- (1) Use the [↑] [↓] keys to move the cursor to item #10102, then press the menu [Manual adjust].
➔ The menu and the selected line are highlighted.
The current setting value is displayed at "Current adjust data".
A ch0 +10V analog voltage is output at this time.
- (2) Monitor the analog voltage.
➔ Adjust the + gain until the monitor voltage is $10V \pm 3.5mV$. The setting range -999 to 999.
- (3) <For 10V or higher>
Press the menu [Voltage -1] or [Voltage -10]

<For less than 10V>
Press the menu [Voltage +1] or [Voltage +10].
- (4) Press the [INPUT] key.
➔ "Current adjust data" is set as "ch0 + gain", and the adjustment result is enabled.
The menu [Manual adjust]highlighting is cleared.

Adjusting the ch0 - gain

- (1) Use the [↑] [↓] keys to move the cursor to item #10103, then press the menu [Manual adjust].
➔ The menu and the selected line are highlighted.
The current setting value is displayed at "Current adjust data".
A ch0 -10V analog voltage is output at this time.
- (2) Monitor the analog voltage.
➔ Adjust the - gain until the monitor voltage is $-10V \pm 3.5mV$. The setting range -999 to 999.
- (3) <For -10V or higher>
Press the menu [Voltage -1] or [Voltage -10].

<For less than -10V>
Press the menu [Voltage +1] or [Voltage +10].
- (4) Press the [INPUT] key.
➔ "Current adjust data" is set as "ch0 - gain", and the adjustment result is enabled.
The menu [Manual adjust] highlighting is cleared.

6.6 Absolute Position Setting Screen

The Absolute position setting screen is used to set the data for the absolute position of servo axes including arbitrary NC axes and PLC axes.

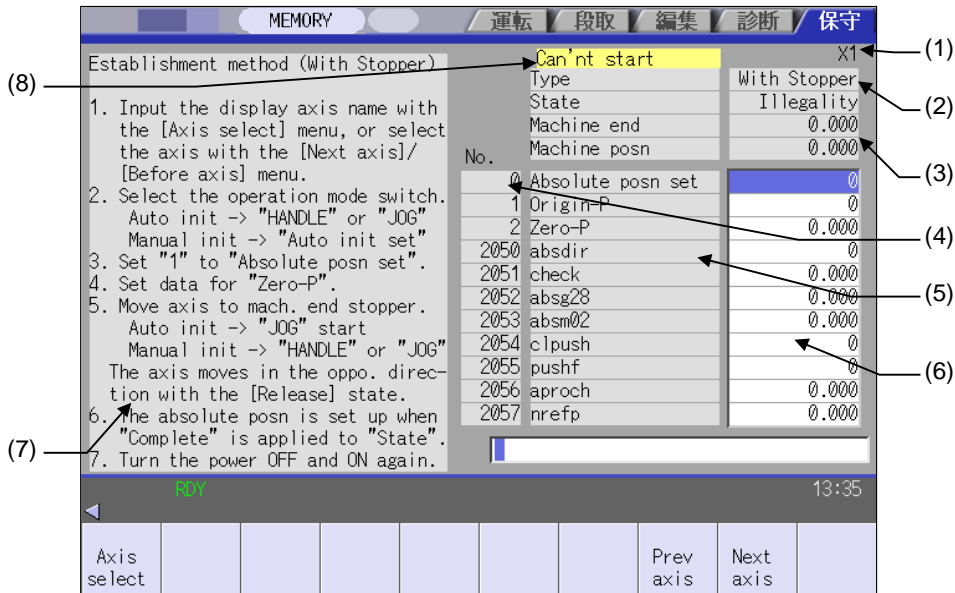

Display items

Display item	Details																						
(1) Axis name	This displays the axis name set with the parameter "#1022 axname2". The axis name can be switched by [Axis select], [Next axis] or [Prev axis].																						
(2) Type of zero point initialization	This displays the type of zero point initialisation for the selected axis. The shortened expression of the zero point initialization method selected with the parameter "#2049 type (type of absolute position detection system)" . <table border="1" style="margin-left: 20px;"> <thead> <tr> <th></th> <th>Displayed expression</th> <th>Type of zero point initialization for absolute position</th> <th>Setting value</th> </tr> </thead> <tbody> <tr> <td>1</td> <td>Inc.</td> <td>Incremental position detection system</td> <td>Other than 1,2,3,4,</td> </tr> <tr> <td>2</td> <td>With Stopper</td> <td rowspan="3">Dogless-type absolute position detection system</td> <td>Machine end stopper method</td> </tr> <tr> <td>3</td> <td>No Stopper</td> <td>Marked point alignment method</td> </tr> <tr> <td>4</td> <td></td> <td>Marked point alignment method II</td> </tr> <tr> <td>5</td> <td>Dog-type</td> <td>Dog-type absolute position detection system</td> <td>3</td> </tr> </tbody> </table>		Displayed expression	Type of zero point initialization for absolute position	Setting value	1	Inc.	Incremental position detection system	Other than 1,2,3,4,	2	With Stopper	Dogless-type absolute position detection system	Machine end stopper method	3	No Stopper	Marked point alignment method	4		Marked point alignment method II	5	Dog-type	Dog-type absolute position detection system	3
	Displayed expression	Type of zero point initialization for absolute position	Setting value																				
1	Inc.	Incremental position detection system	Other than 1,2,3,4,																				
2	With Stopper	Dogless-type absolute position detection system	Machine end stopper method																				
3	No Stopper		Marked point alignment method																				
4			Marked point alignment method II																				
5	Dog-type	Dog-type absolute position detection system	3																				
(3) Progress state	<table border="1" style="margin-left: 20px;"> <tbody> <tr> <td>State</td> <td>This displays the progress state of zero point initialisation. (Note)</td> </tr> <tr> <td>Machine end</td> <td>This displays the distance from the mechanical basic position to the first grid point.</td> </tr> <tr> <td>Machine posn</td> <td>This displays the current machine position. "Not passed" will appear until the axis passes a grid point for the first time.</td> </tr> </tbody> </table>	State	This displays the progress state of zero point initialisation. (Note)	Machine end	This displays the distance from the mechanical basic position to the first grid point.	Machine posn	This displays the current machine position. "Not passed" will appear until the axis passes a grid point for the first time.																
State	This displays the progress state of zero point initialisation. (Note)																						
Machine end	This displays the distance from the mechanical basic position to the first grid point.																						
Machine posn	This displays the current machine position. "Not passed" will appear until the axis passes a grid point for the first time.																						

Display item	Details
(4) Data No	This displays the No., name, and data used to establish the absolute position. - 0 to 2: Internal data - 2050 to 2059: Absolute position parameters
(5) Name	
(6) Data	These can be set also in Absolute position parameter screen. Refer to "Setup Manual" for explanation and setting range of the parameters #2050 to #2059.
(7) Procedures	This shows the procedures to establish the coordinate system by zero point initialization. The contents differ depending on the type of zero point initialization.
(8) Initialization message	This displays a message with the background yellow if an illegal value has been set for the zero point initialization. Refer to the section "Appendix 7.14 Absolute Position Detection-related Operation Messages" for details.

(Note) [Type of zero point initialization] indicates the progress state of zero point initialization as shown below.

1. Dogless-type absolute position detection system Machine end stopper method (manual initialization)		
Order	Display	Details of progress
1	Illegality	While the absolute position is lost.
2	Stopper	From when the menu [Abs pos set] is pressed to when the axis pushes against the machine end stopper.
3	Release	From when the axis pushes against the machine end stopper to when axis starts to move in the counter direction.
4	Ret. Ref. P.	From when the axis moves in the counter direction to when it reaches the grid point immediately before the stopper.
5	Complete	The axis has reached the grid point immediately before the stopper. The absolute position has been established.
2. Dogless-type absolute position detection system Machine end stopper method (automatic initialization)		
Order	Display	Details of progress
1	Illegality	While the absolute position is lost.
2	Jog Start	From when the menu [Abs pos set] is pressed to when a value is set in "Zero-P".
3	Stopper1	From when JOG operation starts to when the axis pushes against the machine end stopper.
4	Zero-P. Rel.	From when the axis pushes against the machine end stopper to when axis reaches the approach point.
5	Stopper2	From when the axis reaches the grid point immediately before the stopper to when it pushes against the machine end stopper.
6	Ret. Ref. P.	From when the axis pushes against the machine end stopper second time to when axis reaches the grid point immediately before the stopper.
7	Complete	The axis has reached the grid point immediately before the stopper. The absolute position has been established.
3. Dogless-type absolute position detection system Marked point alignment method		
Order	Display	Details of progress
1	Illegality	While the absolute position is lost.
2	Origin Set	From when the menu [Abs pos set] is pressed to when "1" is set in "Origin-P".
3	Ret. Ref. P.	While moving in the direction designated with the absolute position parameter #2050.
4	Complete	The axis has reached the grid point immediately before the marked point. The absolute position has been established.
4. Dogless-type absolute position detection system Marked point alignment method II		
Order	Display	Details of progress
1	Illegality	While the absolute position is lost.
2	Origin Set	From when the menu [Abs pos set] is pressed to when "1" is set in "Origin-P".
3	Complete	With the sequence above, the absolute position is established.
5. Dog-type absolute position detection system		
Order	Display	Details of progress
1	Illegality	While the absolute position is lost.
2	Zero-P. Rel.	After dog-type manual or automatic reference position return is started.
3	Complete	Axis has returned to the reference position.

Menus

Menu	Details	Type	Reference
Axis select	After selecting this menu, set the axis name, and press the [INPUT] key to display the axis name and related data.	A	6.6.1 Selecting an Axis
Prev axis	This switches the data display to the previous axis' data When the first data is displayed, the last axis data will be displayed.	C	
Next Ax	This switches the data display to the next axis' data When the last data is displayed, the first axis data will be displayed.	C	

6.6.1 Selecting the Axis

Procedures

- (1) Press the menu [Axis select].
 - ➔ The menu is highlighted.
The cursor appears in the input area.

- (2) Set the axis name (which was set with "#1022 axname2") and press [INPUT] key.
 - ➔ The axis name and data change.
Procedures displays according to the selected initialization type.









6.6.2 Carrying Out Dogless-type Zero Point Initialization

Procedures (Machine end stopper method : manual method)

Set the following parameter beforehand in the "Abs.Posit.Param." screen.

Parameter	Setting value
#2049 type (absolute position detection type)	1 (machine end stopper method is selected)
#2054 clpush (current limit)	0 to 100
#2059 zerbas (zero point return parameter)	1 (on the grid point immediately before the stopper)

The parameters other than "#2049 type" can be set in the "Zero point set" screen.

- (1) Select the axis that "#2049 type" is "1".  Refer to "6.6.1 Selecting the Axis" for procedures to select the axis.
- (2) Select the HANDLE mode or "JOG" mode.
- (3) Input "1" to "Absolute posn set".  The input value appears at "Absolute posn set".
- (4) Input an arbitrary value to "#2 Zero-P".  The input value appears at "#2 Zero-P".
- (5) Move the axis toward the machine end stopper. → a  State: [Stopper]
Machine end: Distance between stopper and grid point
Machine posn: [Not passed] → current machine position
- (6) Hit against the machine end stopper. → b  State: [Stopper]
- The current has reached its limit for given time. → c  State: [Release]
- (7) Move the axis in the counter direction. → d  State: [Ret. Ref. P.]
- The axis has reached the grid point immediately before the stopper. → e  State: [Complete]
This completes zero point initialization. Turn the power OFF and ON after the initialization for all axes.

If "#2059 zerbas" is "0" (absolute position origin point = mechanical basic position), axis will stop automatically at this point without moving in the opposite direction and "Complete" appears at [State] and "0.000" at [Machine end].

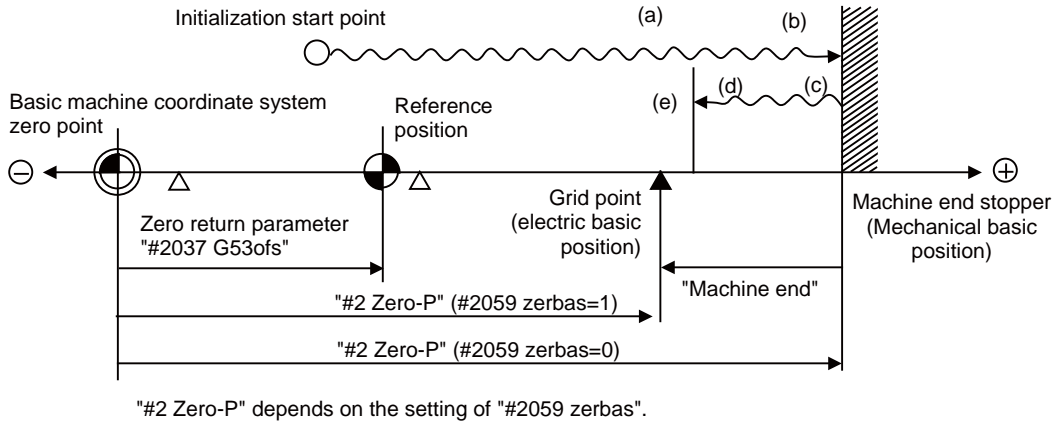

- (Note 1) To change just the basic machine coordinate zero point, set "#0 Absolute posn set" and "#2 Zero-P", and then turn the power OFF and ON.
- (Note 2) If pressing against the machine end is attempted without passing the grip point once after turning the power ON, the operation message "Not passed on grid" will appear. Return to a point before the last grid, and then repeat from step of pressing against the machine end stopper.
- (Note 3) If the first grid point is covered by the grid mask (#2028 grmask) as a result of return to the electric basic position, the axis stops at the next grid point.
Note that zero-point shift amount (#2027 G28sft) is invalid.

Procedures (Machine end stopper method : automatic method)

Set the following parameter beforehand in the "Abs.Posit.Param." screen.

Parameter	Setting value
#2049 type (absolute position detection type)	1 (machine end stopper method is selected)
#2054 clpush (current limit)	0 to 100
#2055 pushf (push speed)	1 to 999
#2056 aproch (approach point)	0 to 999.999
#2059 zerbasp (zero point return parameter)	1 (on the grid point immediately before the stopper)

The parameters other than "#2049 type" can be set in the "Zero point set" screen.

- (1) Select the axis that "#2049 type" is "1".  Refer to "6.6.1 Selecting the Axis" for procedures to select the axis.

- (2) Select the "Auto init set" mode.

- (3) Input "1" to "Absolute posn set".  The input value appears at "Absolute posn set".

- (4) Input an arbitrary value to "#2 Zero-P".  The input value appears at "#2 Zero-P".

- (5) Start JOG operation.  State: [Stopper1]
Machine posn: [Not passed] -> current machine position

- The axis moves toward the machine end stopper at the push speed (#2055).  State: [Stopper1]
→ a

- The axis pushes against the machine end stopper. After the current reached its limit for given time, the axis returns toward the approach point at the "push speed". → b  State: [Zero-P. Rel.]

- After arrived at the approach point, the axis moves toward the machine end stopper at the "push speed". → c  State: [Stopper2]

- The axis pushes against the machine end stopper. After the current reached its limit for given time, the axis returns toward the grid point immediately before the stopper at the "push speed". → d  State: [Ret. Ref. P.]

- The axis has reached the grid point immediately before the stopper. → e  State: [Complete]
Machine end: Distance between stopper and grid point
This completes zero point initialization. Turn the power OFF and ON after the initialization for all axes.

If "#2059 zerbas" is "0" (absolute position origin point = mechanical basic position), axis will stop automatically at this point without moving in the opposite direction and "Complete" appears at [State] and "0.000" at [Machine end].

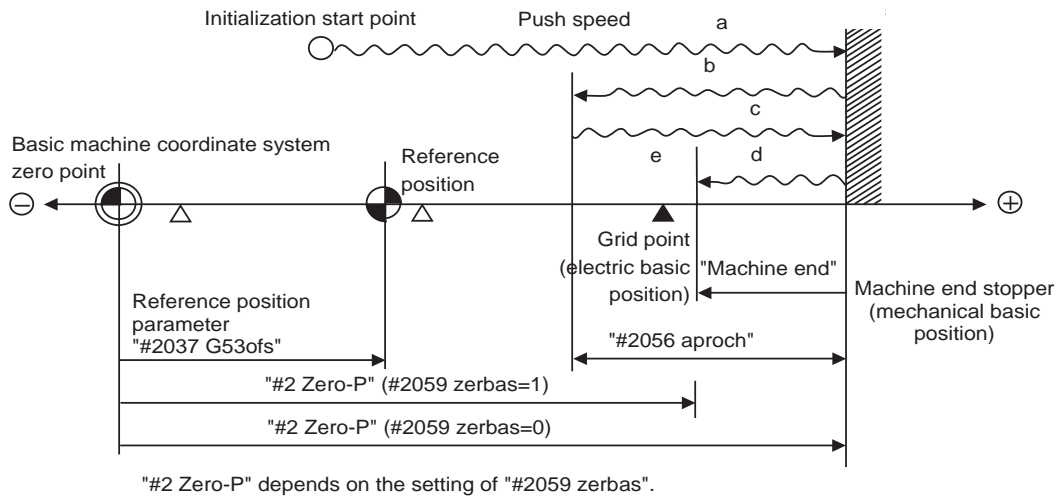

- (Note 1) To change just the basic machine coordinate zero point, set "#0 Absolute posn set" and "#2 Zero-P", and then turn the power OFF and ON.
- (Note 2) If pressing against the machine end is attempted without passing the grip point once after turning the power ON, the operation message "Not passed on grid" will appear. Return to a point before the last grid, and then repeat from step of pressing against the machine end stopper.
- (Note 3) If the first grid point is covered by the grid mask (#2028 grmask) as a result of return to the electric basic position, the axis stops at the next grid point.
Note that zero-point shift amount (#2027 G28sft) is invalid.
- (Note 4) Acceleration/deceleration during movement at the specified push speed is performed in smoothing-off (step feed) mode.
- (Note 5) If "0" is specified for "#2056 aproch" of the absolute position parameters, the machine zero point is regarded as the approach point.
- (Note 6) Automatic initialization is interrupted if one of the following events occurs. If it is interrupted, [State] indicates "Jog Start" (after selecting the "Auto init set" mode if it is caused by mode change), so restart operation from the step of JOG-start.
 - An absolute position detection alarm occurs.
 - Operation preparation signal turns OFF.
 - The mode is changed.
 - The system is reset.
 If [State] is "Complete" before automatic initialization is started, "State" returns to "Complete" when power is turned OFF and ON again without restarting the operation.

(Note 7) Automatic initialization cannot be started in the following cases. The operation message "Can't start" will appear if starting is attempted.

- When "#0 Absolute posn set" is not set.
- When the "#2 Zero-P" setting is inappropriate.
- When "#2055 pushf" is not set.
- When "Z71 Abs encoder failure 0005" has occurred.

In the above cases, if the "#2 Zero-P" setting is inappropriate, this means that the relation of "#2 Zero-P" and "#2037 G53ofs" is inappropriate. That is, if "#2 Zero-P" is smaller than the "#2037 G53ofs", the machine end stopper will be located between the basic machine coordinate system zero point and reference position; this disables automatic initialization. (Refer to the following left figure.)

If "#2 Zero-P" is set to "0", the machine end stopper direction is unpredictable; this also disables automatic initialization. (Refer to the following right figure.)

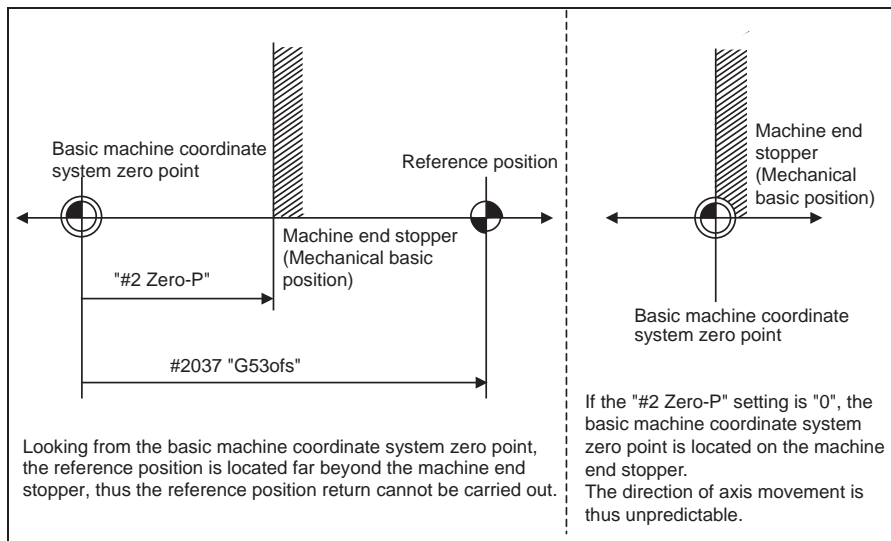

Procedures (Marked point alignment method)

Set the following parameter beforehand in the "Abs.Posit.Param." screen.

Parameter	Setting value
#2049 type (absolute position detection type)	2 (marked point alignment method is selected)
#2050 absdir (basic Z - direction)	0/1

- (1) Select the axis that "#2049 type" is "2".  Refer to "6.6.1 Selecting the Axis" for procedures to select the axis.

- (2) Select the HANDLE mode, HANDLE-AX mode, or JOG mode.

- (3) Input "1" to "#0 Absolute posn set".  The input value appears at "#0 Absolute posn set".

- (4) Input an arbitrary value to "#2 Zero-P".  The input value appears at "#2 Zero-P".

- (5) Move the axis toward the mechanical basic position and align it to the marked point. → a  State: [Origin Set]
Machine posn: [Not passed] -> current machine position

- (6) Input "1" to "#1 Origin-P".  The input value appears at "#1 Origin-P".

- (7) Move the axis in the direction designated with the parameter "#2050 absdir". → b  State: [Ret. Ref. P.]
Machine end: Distance between machine basic point (marked point) and the first grid point

- The axis reaches the first grid point. → c  State: [Complete]
This completes zero point initialization. Turn the power OFF and ON after the initialization for all axes.

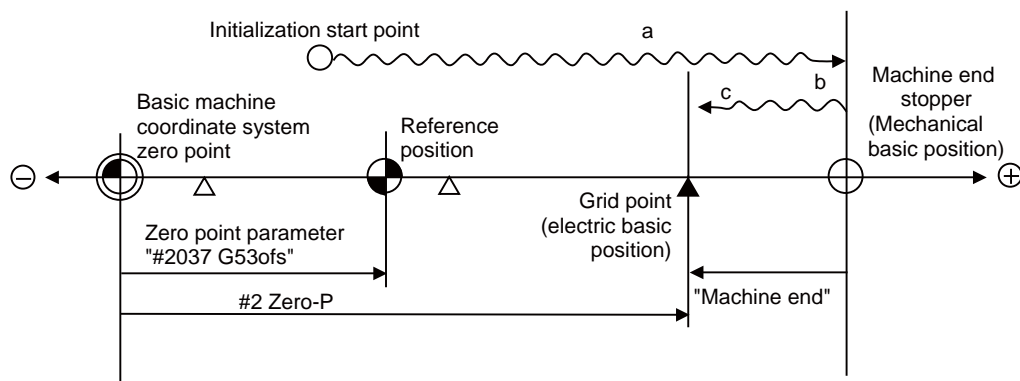

- (Note 1) To change just the basic machine coordinate zero point, set "#0 Absolute posn set" and "#2 Zero-P", and then turn the power OFF and ON.
- (Note 2) If aligning axis on the marked point is attempted without passing the grip point once after turning the power ON, the operation message "Not passed on grid" will appear. Return to a point before the last grid, and then repeat from step of aligning the axis on the marked point.
- (Note 3) If the first grid point is covered by the grid mask (#2028 gmask) as a result of return to the electric basic position, the axis stops at the next grid point.
Note that zero-point shift amount (#2027 G28sft) is invalid.
- (Note 4) Reconfirm the "absdir" setting if the machine does not move in the direction of "#2050 absdir". The machine will move only in the positive direction when set to "0", and the negative direction when set to "1".

Procedures (Marked point alignment method II)

Set the following parameter beforehand in the "Abs.Posit.Param." screen.

Parameter	Setting value
#2049 type (absolute position detection type)	4 (marked point alignment method II is selected)

- (1) Select the axis that "#2049 type" is "4". ➡ Refer to "6.6.1 Selecting the Axis" for procedures to select the axis.

- (2) Select the HANDLE mode, HANDLE FEED AXIS SELECT mode, or JOG mode.

- (3) Input "1" to "#0 Absolute posn set". ➡ The input value appears at "#0 Absolute posn set".

- (4) Input an arbitrary value to "#2 Zero-P". ➡ The input value appears at "#2 Zero-P".

- Move the axis toward the mechanical basic position and align it to the marked point. → a ➡ State: [Origin Set]

- Input "1" to "#1 Origin-P". ➡ The input value appears at "#1 Origin-P".
State: [Complete]
Machine end: 0.000
Machine posn: The value set in "#2 ZERO"

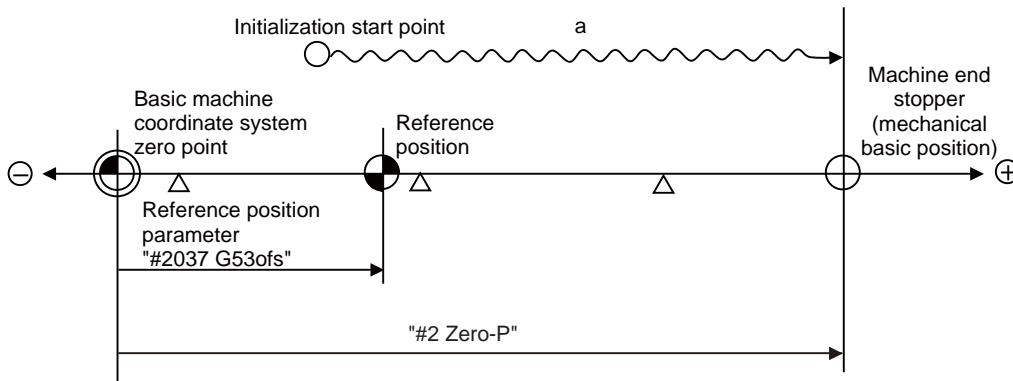

- (Note 1) To change just the basic machine coordinate zero point, set "#0 Absolute posn set" and "#2 Zero-P", and then turn the power OFF and ON.
- (Note 2) If aligning axis on the marked point is attempted without passing the grip point once after turning the power ON, the operation message "Not passed on grid" will appear. Return to a point before the last grid, and then repeat from step of aligning the axis on the marked point.
- (Note 3) If the first grid point is covered by the grid mask (#2028 grmask) as a result of return to the electric basic position, the axis stops at the next grid point.
Note that zero-point shift amount (#2027 G28sft) is invalid.

6.6.3 Carrying Out Dog-type Zero Point Initialization

Procedures (Marked point alignment method II)

Set the following parameter beforehand in the "Abs.Posit.Param." screen.

Parameter	Setting value
#2049 type (absolute position detection type)	3 (dog-type method is selected)

(1) Select the axis that "#2049 type" is "3".  Refer to "6.6.1 Selecting the Axis" for procedures to select the axis.

(2) Carry out the manual or automatic dog-type reference position return.  State: [Zero-P. Rel.]
Machine posn: Current machine position

Reference position return completes.  State: [Complete]
Machine end: 0.000
This completes zero point initialization. Turn the power OFF and ON after the initialization for all axes.

(Note 1) If the dog-type reference position return is interrupted by resetting, the previous state ("Complete" or "Illegality") will display in the [State] column.

(Note 2) With dog-type reference position return, reference position return can be executed again even if the [State] is "Complete".

6.6.4 Precautions

Precautions common for the initialization operation

- (1) The "#0 Absolute posn set" parameter (axis for which zero point is to be initialized) can be set simultaneously for all axes or individually for each axis.
- (2) The "#0 Absolute posn set" parameter cannot be turned OFF with the keys. It is turned OFF when the power is turned ON again.
- (3) "#2 ZERO-P" can be set at any time as long as "#0 Absolute posn set" is set to "1".
- (4) The grid point must be passed at least once after turning the power ON before initializing the zero point. If the grid point has not been passed, the operation message "Not passed on grid" will appear at the "Machine posn".
- (5) When the absolute position is established, the required data will be stored in the memory.

Precautions common for the dogless-type absolute position detector

(1) Example of setting "#2 Zero-P" parameter

For the "#2 Zero-P" parameter, set the coordinate value of the absolute position origin point (mechanical basic position or electrical basic position) looking from the basic machine coordinate system zero point.

<p>(Example 1) To set the zero point at 50.0mm before absolute position origin point on + end</p>	
<p>(Example 2) To set the zero point at 400.0mm before the machine basic position or absolute position origin point on - end.</p>	
<p>(Example 3) To set the basic machine coordinate system zero point on the grid point, calculate the "#2 Zero-P" parameter setting value as shown below using the value displayed at "Machine end". "Machine end" shows the distance from the mechanical basic position to the previous grid point. (Note that when setting the electrical basic position coordinate value in "#2 Zero-P", the "Machine end" value does not need to be considered.)</p>	
<p>To set the third grid point as the zero point when the "Machine end" display is -5.3 at the + end basic position. (Example of 10.0mm grid interval.)</p>	

(2) Setting the reference position

The reference position can be set as shown below by setting the "#2037 G53ofs".

<p>(Example 1) To set the reference position to the same position as the basic machine coordinate system zero point.</p>	
<p>(Example 2) To set the reference position at a position 200.0mm to the + side from the basic machine coordinate zero point. (To set the basic machine coordinate system zero point 300.0mm front of the absolute position origin point.)</p>	

6.7 Servo Diagnosis Screen

The followings can be confirmed in the servo diagnosis screen: the number of servo alarm of servo unit/spindle unit, DA output information, PLG diagnosis (spindle), and the maintenance diagnosis information of servo/spindle unit such as alarm cause counter.

[Servo unit]

		X	Y	Z
Alarm times	29			
(1) → Alarm times	30			
Alarm times	31			
Alarm times	32			
(2) → 34 AL cause cnt	accu	0	0	0
	freq	0	0	0
36 AL cause cnt	accu	0	0	0
	freq	0	0	0
38 AL cause cnt	accu	0	0	0
	freq	0	0	0
(3) → DA Address	1			
DA output	1			
DA Address	2			
DA output	2			

RDY 15:57

Servo unit | All num clr | Alarm num clr | All cnt clr

[Spindle unit]

(1) Display of the DA output data

		S1
Alarm times	29	
(1) → Alarm times	30	
Alarm times	31	
Alarm times	32	
(2) → 34 AL cause cnt	accu	0
	freq	0
36 AL cause cnt	accu	0
	freq	0
38 AL cause cnt	accu	0
	freq	0
(3) → DA Address	1	
DA output	1	
DA Address	2	
DA output	2	

EMG 17:29

Servo unit | Spindle unit | PLG diagn | All num clr | Alarm num clr | All cnt clr

(2) Display of the spindle PLG diagnosis information

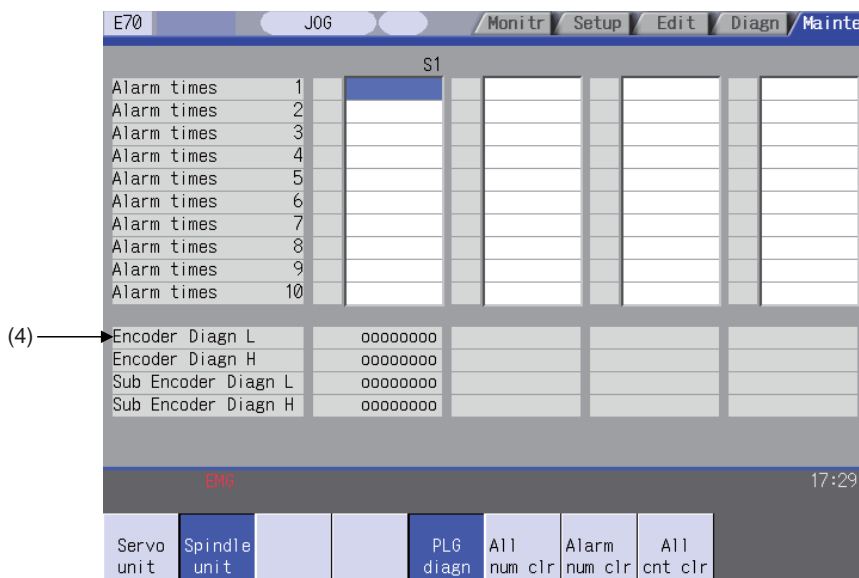

Display items

Display item	Details
(1) Alarm times	Currently not supported.
(2) Alarm cause counter	An alarm occurs when the specified number of conditions are met. This counter displays the number of times in which the alarm occurrence condition is met since the drive unit power was turned ON. The number of times can be cleared for each axis with [All cnt clr]. accu ... Displays the number of times in which the alarm occurrence condition was met since the drive unit power was turned ON. freq ... Displays the peak hold value when the alarm occurrence condition is met per constant cycle.
(3) DA output	Currently not supported.
(4) Spindle PLG diagnosis information (Spindle drive unit only)	Displays the data for each axis Encoder Diagn L ... Displays the output signal (Low) of the motor end PLG Encoder Diagn H ... Displays the output signal (High) of the motor end PLG Sub Encoder Diagn L ... Displays the output signal (Low) of the machine end PLG Sub Encoder Diagn H ... Displays the output signal (High) of the machine end PLG

(Note) PLG (pulse generator) detects the pulse signal and it is used to detect the rotation state of the motor.

Menus

Menu	Details	Type	Reference
Servo unit	Displays the servo unit diagnosis information in the data display area.	B	
Spindle unit	Displays the spindle unit diagnosis information in the data display area. (Note) When the parameter "#1039 spinno" is set to "0", this menu will not be displayed.	B	
PLG diagn	Switches the display between the DA output and the spindle PLG diagnosis information. Pressing this button again this menu is highlighted, the display switches to the DA output. (Note 1) When the parameter "#1039 spinno" is set to "0", this menu will not be displayed. (Note 2) Even when the parameter "#1039 spinno" is set to other than "0", this menu will be grayed out and cannot be selected while displaying the servo unit diagnosis information.	B	
All num clr	Currently not supported and cannot be used.	A	
Alarm num clr	Currently not supported and cannot be used.	A	
All cnt clr	Clears the all values of "AL cause cnt accu" and "freq" of the axis where the cursor is placed to 0.	A	
Next Ax	Displays the data of four axes from the next axis. This menu is displayed only when there are five or more servo axes or spindle.	C	

6.8 Diagnosis Data Collection Setting Screen

The NC automatically collects diagnosis data based on the "Sampling spec" and "Collecting data select" settings specified at this screen.

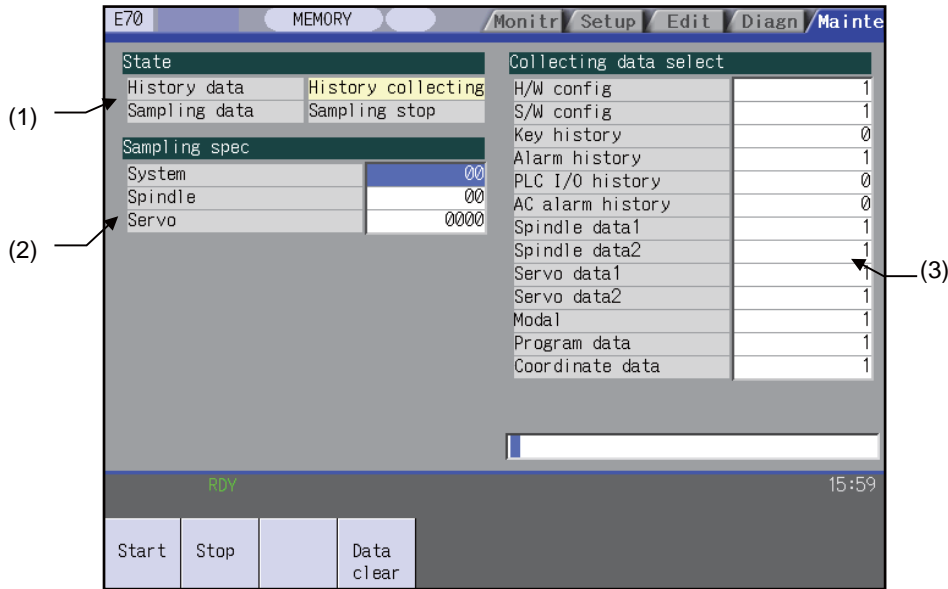



Display items

Display item	Details
(1) State	Display the history data and sampling data collection status.
History data	Display the history data collection status. History collecting: History data collection is in progress. History stop: History data collection is stopped.
Sampling data	Display the sampling data collection status. Sampling: Sampling data collection is in progress. Sampling stop: Sampling data collection is stopped. Sampling invalid: Sampling data collection is disabled.
(2) Sampling spec	Specify the part system, spindle, and servo axes where sampling data is to be collected.
System	Specify the part systems where sampling data is not to be collected. When "0" is set, sampling is carried out for all part systems. This setting is ignored if a non-existent part system is specified. (The E70 Series is one-part system control.)
Spindle	Specify the spindle where sampling data is not to be collected. When "0" is set, sampling is carried out for all spindles. This setting is ignored if a non-existent spindle is specified.
Servo	Specify the servo axes where sampling data is not to be collected. When "0" is set, sampling is carried out for all axes. This setting is ignored if a non-existent servo axis is specified.

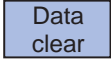

Display item	Details
(3) Collecting data select	This selects the diagnosis data to be collected. (0 : Collected. 1 : Not collected.)
H/W config	This selects whether or not H/W configuration data is collected.
S/W config	This selects whether or not S/W configuration data is collected.
Key history	This selects whether or not key history data is collected.
Alarm history	This selects whether or not alarm history data is collected.
PLC I/O history	This selects whether or not PLC input/output signal history data is collected.
AC alarm history	This selects whether or not AC input power error history data is collected.
Spindle data 1	This selects whether or not spindle current waveform (speed FB, current FB, current command, position FB, position command, droop) data is collected.
Spindle data 2	This selects whether or not spindle current waveform (driver statuses 1,3,4) data is collected.
Servo data 1	This selects whether or not servo current waveform (speed FB, current FB, current command, position FB, position command, droop) data is collected.
Servo data 2	This selects whether or not servo current waveform (detector position Rn, Pn) data is collected.
Modal	This selects whether or not modal information (information for each running block (block data, G-command modal, workpiece coordinate offset)) data is collected.
Program data	This selects whether or not program data (information for each running block (program coordinate position, manual interruption amount, command termination)) data is collected.
Coordinate data	This selects whether or not coordinate data (information for each running block (relative position, machine FB position, machine command position)) data is collected.

Menus

Menu	Details	Type	Reference
	This begins collecting sampling data and history data.	A	6.8.1 Performing a Data Collection Operation
	This stops the sampling data and history data collection operation.	A	6.8.2 Stopping a Data Collection Operation
	This stops the sampling data and history data collection operation, and clears the collected data.	A	6.8.3 Clearing a Collected Data



6.8.1 Performing a Data Collection Operation

Operation methods

- (1) Press the menu [Start].  An operation message "The collection begin?" appears.
- (2) Press [Y] or [INPUT] key.  Data collection begins, and "History collecting" and "Sampling" appears in the status column.



6.8.2 Stopping a Data Collection Operation

Operation methods

- (1) Press the menu [Stop].  An operation message "The collection stop?" appears.
- (2) Press [Y] or [INPUT] key.  Data collection stops, and "History stop" and "Sampling stop" appears in the status column.
To resume data collection, press the menu [Start] .

6.8.3 Clearing a Collected Data

Operation methods

- (1) Press the menu [Data clear].  An operation message "Execute the collection data clear?" appears.
- (2) Press [Y] or [INPUT] key.  The collected data is cleared.
"Stop" appears in the status column.
To resume data collection, press the menu [Start] .

II MACHINE OPERATIONS

This chapter explains the functions and operation method of the machine operation switches for operation (automatic operation and manual operation) by using the illustration of the machine operation panel. The actual machine operation and motion vary by machine specification. Refer to the operation manual issued by the machine tool builder. Use this chapter for reference.

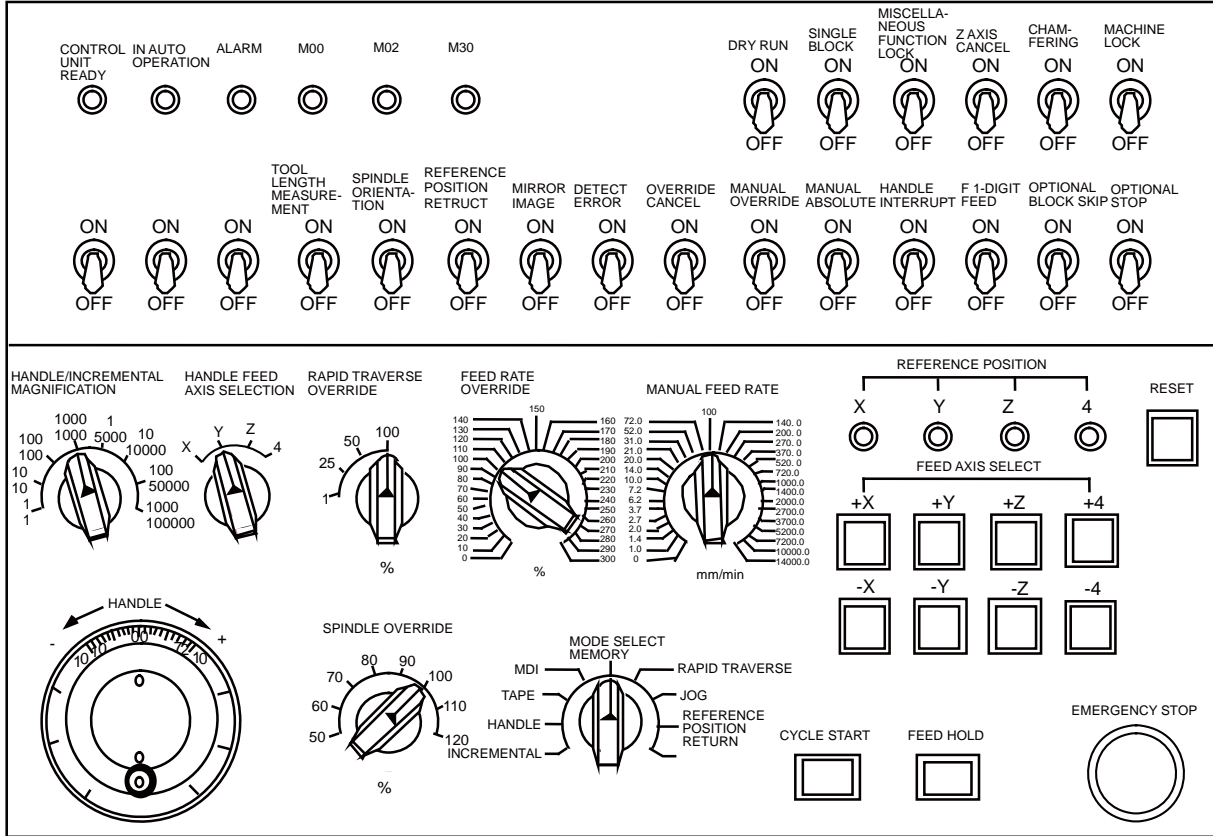





Operation State

1.1 Operation State Correlation Diagram

The controller operation state changes momentarily according to the program contents or signals from the operation panel or machine. The operation states are roughly classified into power OFF, not ready, and ready. Manual mode operation is enabled in the operation complete state.

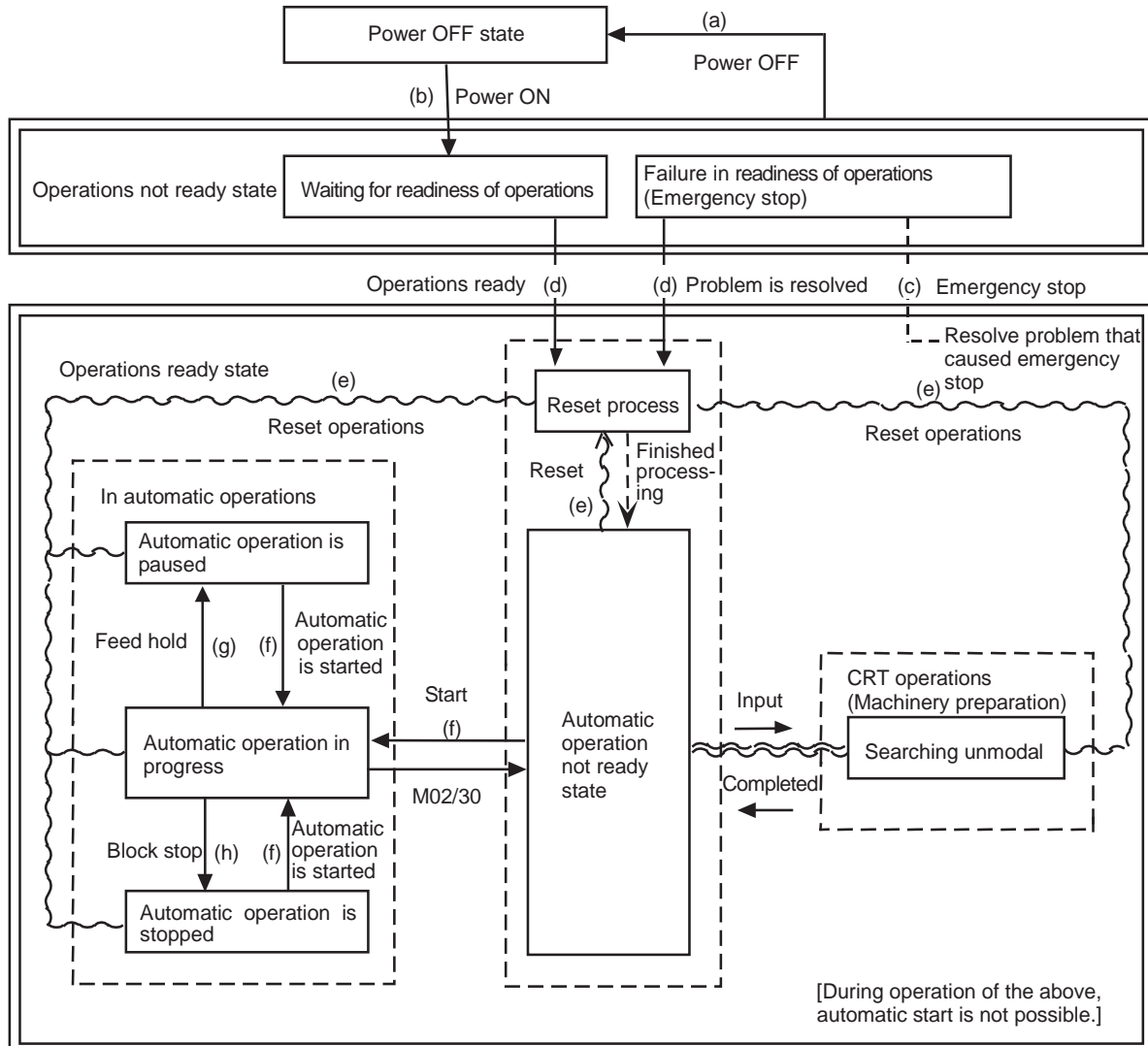

Operation state correlation diagram

1.2 Power OFF

The power OFF state means that no power is supplied to the control circuit.

- (1) From any other state to power OFF (Transition of operation state correlation diagram (a))
 - When POWER OFF signal is input from the machine;
 - When power supplied from the machine to controller is turned OFF; or
 - When power unit fuse in the controller blows.

1.3 Operations Not Ready

The operation not ready state means that the system is not ready to run because of the controller itself or the machine, even though power is supplied to the NC unit control circuit. The RUN READY lamp on the setting and display unit is OFF.

- (1) From power OFF to not ready (Transition of operation state correlation diagram (b))
 - When POWER ON signal is input from the machine.
- (2) From ready to not ready (Transition of operation state correlation diagram (c))
 - When EMG (emergency stop) is displayed on the setting and display unit; or
 - When any of the following alarms is displayed on the setting and display unit;
Servo alarm, feedback alarm, excessive error alarm, watch dog, MCP alarm.

1.4 Operations Ready

The operations ready state means that power is supplied to the NC unit control circuit and the system is ready to run. The READY lamp on the setting and display unit is ON.

The state is furthermore classified into the following four:

1.4.1 Reset

The reset state means that the controller is reset.

- (1) From not ready to reset (Transition of operation state correlation diagram (d))

This state is also called initial state.

 - When about four seconds has passed after the power is turned ON.
- (2) From another ready state to reset (Transition of operation state correlation diagram (e))
 - When the RESET key on the setting and display unit is turned ON;
 - When external reset signal is input from the machine; or
 - When M02 or M30 is executed (depending on the machine specifications).

1.4.2 Automatic Operation in Progress

The automatic operation in progress state means running operations in automatic mode. The IN-AUTO OPERATION lamp on the machine operation panel is ON.

- (1) From another ready state to automatic operation in progress (Transition of operation state correlation diagram (f))
 - When the CYCLE START switch on the machine operation panel is pressed in automatic mode.

1.4.3 Automatic Operation Pause

The automatic operation pause state means that operation or motion temporarily pauses during execution of one block during the automatic operation start. The AUTO PAUSE lamp on the machine operation panel is ON and the AUTO START lamp is OFF.

- (1) From automatic operation start to automatic pause (Transition of operation state correlation diagram (g))
 - When the FEED HOLD switch on the machine operation panel is turned ON; or
 - When automatic mode input is out.

1.4.4 Automatic Operation Stop

The automatic operation stop state means that execution of one block is completed and stopped during automatic operation start. Both the AUTO START and AUTO PAUSE lamps on the machine operation panel are OFF.

- (1) From automatic operation in progress to automatic operation stop (Transition of operation state correlation diagram (h))
 - When the SINGLE BLOCK switch on the machine operation panel is turned ON and execution of the block is completed; or
 - When automatic mode input is changed to another automatic mode input.



CAUTION



Stay out of the moveable range of the machine during automatic operation. Keep hands, feet and face away from the rotating spindle.

Indicator Lamps

2.1 Control Unit Ready

The CONTROL UNIT READY lamp indicates that the control unit is ready to run. The lamp goes OFF at emergency stop or when an alarm occurs in the drive or operation block.

2.2 In Automatic Operation

The IN AUTO OPERATION lamp is ON from CYCLE START switch turning ON in the automatic operation mode (memory, tape, or MDI) to the program end after M02 or M30 execution, reset, or emergency stop.

2.3 Automatic Operation Start Busy

The AUTO START BUSY lamp indicates that the controller is executing control in the automatic operation mode. It is ON from the automatic operation start state entered when the CYCLE START switch is pressed in the automatic operation mode (tape, memory, or MDI) to the automatic operation start end such as the automatic operation pause busy state entered when the FEED HOLD switch is pressed or block completion stop (block stop).

2.4 Automatic Operation Pause Busy

The AUTO PAUSE lamp is ON from AUTO PAUSE switch turning on to AUTO START switch turning ON or when the mode selection switch is changed from the automatic to manual mode during the automatic operation.

2.5 Return to Reference Position

Output is executed when the controlled axis arrives at the reference position when manual reference position return, automatic reference position return, or reference position collation (check).

2.6 Alarm

The ALARM lamp goes ON when an alarm occurs during NC running.

2.7 M00

If M00 given in a program is executed during automatic operation, automatic operation stop is performed after execution of the M00 block is completed. The M00 lamp is turned ON. (This depends on PLC processing.)

2.8 M02/M30

When M02 or M30 is executed during automatic operation, the NC unit reaches the program end and the M02 or M30 lamp is turned ON. (This depends on PLC processing.)

Reset Switch and Emergency Stop Button

3.1 Reset Switch

The controller is reset by turning ON the RESET switch on the machine operation panel or the RESET key on the setting and display unit. When the RESET switch or key is turned ON while the controller is running, the following states are to be observed.

- (1) If a movement command is being executed, movement stops with deceleration and the remaining distance in the executing block is cleared.
- (2) If miscellaneous function such as M, S, or T is being executed, execution of the miscellaneous function is interrupted.
- (3) The active and buffer memory contents and display are cleared.
- (4) If a program error is being occurred, the program error state is cleared and the ALARM lamp goes OFF.
- (5) If the reset switch is turned ON while the input/output device is running, the power will be cut off.
- (6) When the reset switch is turned ON, the modal state will return to its original state.

3.2 Emergency Stop Button

The EMERGENCY STOP button is a red mushroom-shaped pushbutton. The unready state is set by pressing the EMERGENCY STOP button. During emergency stop, the READY lamp goes OFF and automatic operation and manual operation do not work. The controller is reset at that time.

If the EMERGENCY STOP button is pressed when a movement command is executed, the moving axis stops and all other machine motions also stop.

When the EMERGENCY STOP button is released, the READY lamp goes ON in about one second and operation enable state (READY state) is entered.

When parameter is emergency stop hold type, even if the EMERGENCY STOP button is released, the emergency stop state is held. To release the emergency stop state, turn ON the RESET switch.

When the EMERGENCY STOP LIMIT switch of each axis works, the same state as when the EMERGENCY STOP button were pressed may be entered depending on the machine specifications.

CAUTION

 If the axis overruns or emits an abnormal noise, immediately press the emergency stop button and stop the axis.

4

Operation Mode

4.1 Mode Selection Switch

The MODE SELECT switch is used to determine the controller operation mode.

Jog feed mode:	Select the mode to move the controlled axis consecutively at manual feedrate.	
Rapid traverse feed mode:	Select the mode to move the controlled axis consecutively at rapid traverse feedrate.	
Return to reference position mode:	Select the mode to position the controlled axis at the machine reference position manually.	
Incremental mode:	Select the mode to move the controlled axis for a given distance.	
Handle feed mode:	Select the mode to move the controlled axis by using the manual handle.	
Memory Mode:	Select the mode for memory operation.	
Tape mode:	Select the mode for tape operation.	
MDI mode:	Select the mode for MDI operation.	

(Note 1) Refer to the section 1.4 for the running state when a mode is changed to another one during automatic operation.

4.2 Jog Feed Mode

The jog feed mode enables the machine to be moved by hand consecutively at the feedrate set by using the MANUAL FEED RATE switch. The jog feed mode is started by using the FEED AXIS SELECT switch.

Refer to the section 5 for the MANUAL FEED RATE switch.

Operation procedure

- (1) Using the MODE SELECT switch, select the jog mode.
- (2) Using the MANUAL FEED RATE switch, set the feedrate.
The feedrate unit is the travel distance (mm) per minute.
- (3) To move the controlled axis, turn on the FEED AXIS SELECT switch. The controlled axis is moved while the switch is turned on.
When the switch is turned off, the controlled axis stops with deceleration.

(Note 1) When the MANUAL OVERRIDE switch on the operation panel is turned ON, the override value set by using the FEED RATE OVERRIDE switch takes precedence over the feedrate set by using the MANUAL FEED RATE switch.

4.3 Rapid Traverse Feed Mode

The rapid traverse feed mode enables the machine to be moved consecutively at rapid traverse feedrate manually.

The rapid traverse feedrate can be changed its speed in four steps by using the RAPID TRAVERSE OVERRIDE switch.

The rapid traverse feed mode is started by using the FEED AXIS SELECT switch.

(Note 1) Refer to the manual issued by the machine tool builder for the rapid traverse feedrate.

(Note 2) Refer to the section 5 for the RAPID TRAVERSE OVERRIDE switch.

Operation procedure

- (1) Using the MODE SELECT switch, select the rapid traverse feed mode.
- (2) Using the RAPID TRAVERSE OVERRIDE switch, set arbitrary override value.
- (3) To move the controlled axis, turn ON the FEED AXIS SELECT switch. The controlled axis is moved while the switch is turned ON.

When the switch is turned OFF, the controlled axis stops with deceleration.

(Note 1) The override value set by using the CUTTING FEED OVERRIDE switch is not effective for the rapid traverse feedrate; when the override value is 0%, the controlled axis does not move.

4.4 Manual Reference Position Return Mode

4.4.1 Outline

This mode enables a controlled axis to be returned manually to the defined position unique to the machine (reference position).

The first reference position return after the NC power is turned ON becomes the dog mode. For the second or later reference position return, the dog mode or high-speed return can be selected by setting a given parameter.

4.4.2 Detailed Description

Patterns of reference position return are as shown below.

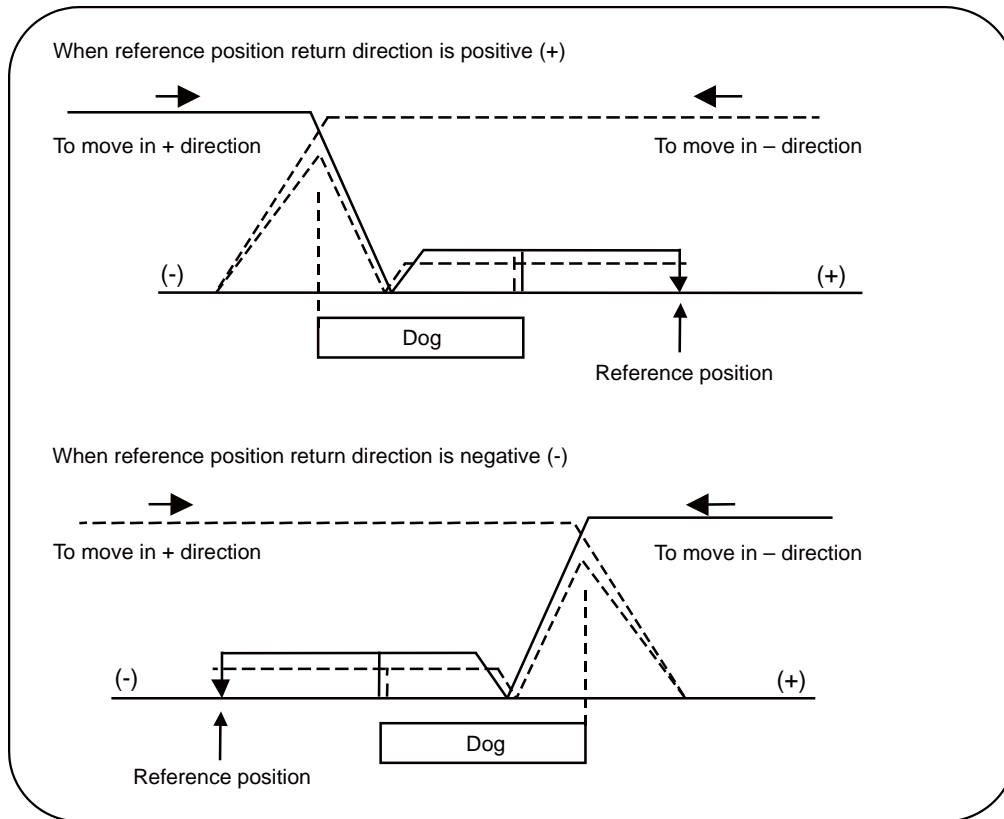

Dog mode reference position return

The steps below describe what happens to the controlled axis when it returns to the reference position for the first time with the power ON and with the machine in an "operations not ready state" (emergency stop is engaged or the servo alarm is ON) or when the parameters are selected in the dog mode.

- (1) The controlled axis is moved in the direction where the near point detection limit switch and dog approach each other in the reference position return mode.
- (2) When the limit switch kicks the dog, the controlled axis once stops with deceleration.
- (3) Next, the controlled axis moves to the reference position at the approach rate set in the parameter.
- (4) When it arrives at the reference position, the reference position arrival signal is output.
- (5) The reference position establishment signal is output.

High-speed reference position return

If high-speed return is set in a given parameter after dog mode reference position return is executed, then high-speed reference position return will be made.

If the return direction is erroneous in high-speed reference position return, an alarm occurs.
A return is made to the reference position at the rapid traverse feedrate.

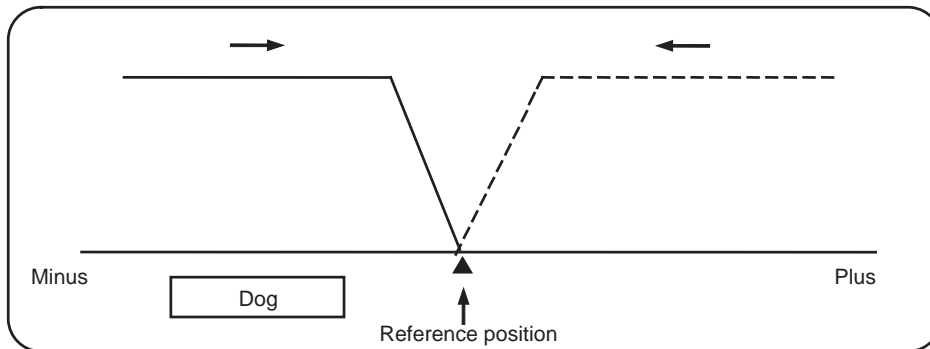

Operation procedure

- (1) Using the MODE SELECT switch, select the reference position return mode.
- (2) Using the RAPID TRAVERSE OVERRIDE switch, set arbitrary override value.

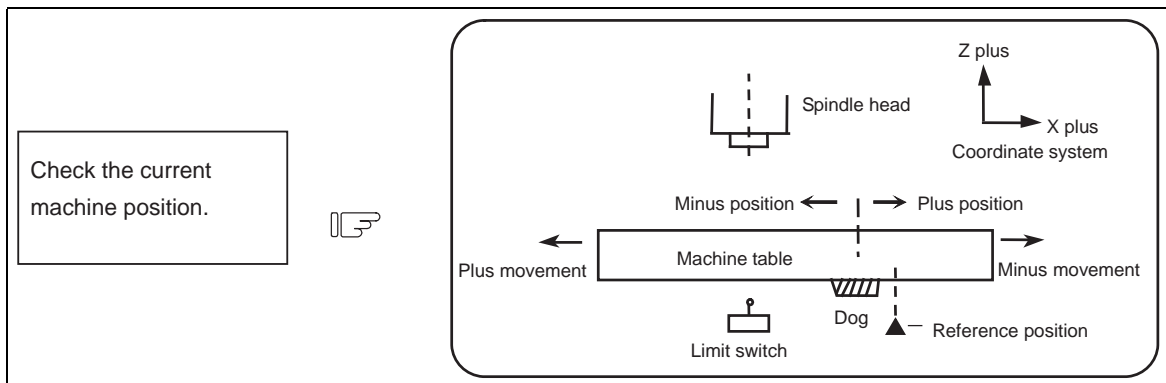

The machine position depends on whether the near point detection limit switch is on the plus or minus side with the near point dog on the machine table as illustrated above as the reference.
When the limit switch exists on the dog, move to either plus or minus.

Using the FEED AXIS SELECT switch, move the machine.
If the limit switch exists in the minus direction as illustrated above, turn ON a plus FEED AXIS SELECT switch.

For dog mode reference position return, turn ON the FEED AXIS SELECT switch (+ or -) in the direction where the dog and limit switch approach each other.

For high-speed reference position return, turn ON the FEED AXIS SELECT switch (+ or -) in the direction that the spindle head approaches the reference position.

Hold the FEED AXIS SELECT switch ON during reference position return until the machine passes by the dog (dog mode) or the REFERENCE POSITION ARRIVAL lamp goes ON (high speed return).

4.4.3 Clear the Shift Amount for Coordinate System Setting When Manually Returning to the Reference Position

When the reference position is reached by the manual reference position return, the coordinate system setting shift amount can be cleared by setting the parameter "#1279 ext15/bit5" to "1".

After returning to the manual reference position, the hypothetical machine coordinate system which includes the coordinate system shift amount switches to the basic machine coordinate system which does not include the coordinate system shift amount. (Refer to the figure below.)

The local coordinate system is canceled at the same time as clearing the coordinate system setting shift amount.

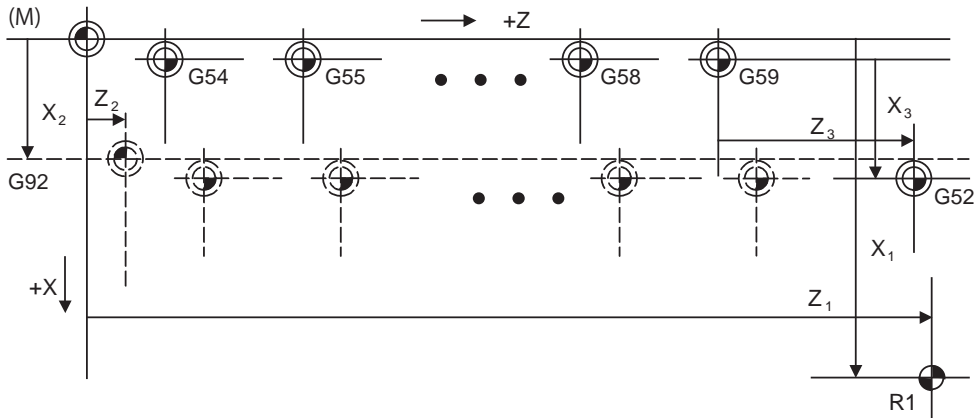

- (M) Basic machine coordinate system
- (G92) Hypothetical machine coordinate system (shifted by G92)
- (G54) Workpiece coordinate system 1
- (G55) Workpiece coordinate system 2
- (G58) Workpiece coordinate system 5
- (G59) Workpiece coordinate system 6
- (G52) Local coordinate system
- (R1) 1st reference position

This function is valid for the manual reference position return, and the coordinate system setting shift amount cannot be cleared when the reference position is reached by the automatic reference position return.

4.5 Incremental Feed Mode

The incremental feed mode enables the controlled axis to be moved at a given distance selected by using the HANDLE/INCREMENTAL MAGNIFICATION switch at the manual feedrate when the FEED AXIS SELECT switch is ON.

Operation procedure

- (1) Using the MODE SELECT switch, select the incremental feed mode.
- (2) Using the HANDLE/INCREMENTAL MAGNIFICATION switch set a travel distance.
- (3) The controlled axis selected by turning ON the FEED AXIS SELECT switch once is moved at a given distance.

4.6 Handle Feed Mode

The controlled axis can be moved by turning the manual handle.

The travel distance per graduation of the handle depends on how the HANDLE/INCREMENTAL MAGNIFICATION switch is set.

The axis that can be moved by using the manual handle is determined by setting the HANDLE FEED AXIS SELECT switch.

Operation procedure

- (1) Using the MODE SELECT switch, select the handle feed mode.
- (2) Using the HANDLE FEED AXIS SELECT switch, select the controlled axis to be moved.
- (3) Using the HANDLE/INCREMENTAL MAGNIFICATION switch, set the travel distance per graduation of the handle.

Move the axis by turning the HANDLE in arbitrary direction.

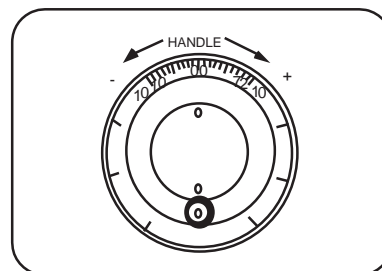

4.7 Memory Mode

In the memory mode, a work program registered in memory is called and automatic operation is executed.

Operation procedure

- (1) Call the work program for memory operation by using the setting and display unit.
- (2) Check whether or not the work program is called normally.
- (3) Using the MODE SELECT switch, select the memory mode.
- (4) Set an arbitrary override value by using the switch RAPID TRAVERSE OVERRIDE, FEED RATE OVERRIDE, SPINDLE OVERRIDE. Normally, set the value to 100%.
- (5) Automatic operation is started by turning ON the CYCLE START switch.
The CYCLE START switch becomes effective when it is once turned ON, then OFF.
To temporarily stop machine motion, turn ON the FEED HOLD switch. The controlled axes being moved stop with deceleration.

When machine motion is stopped by using the FEED HOLD switch, automatic operation will be restarted by turning ON the CYCLE START switch.

Memory operation terminates when M02 or M30 in the program is executed. The M02 or M30 lamp on the machine operation panel is turned ON.

To repeat executing the same program, input the rewind signal by reset & rewind with PLC program.

To forcibly terminate automatic operation, turn ON the RESET switch.

CAUTION

 Carry out dry run operation before actually machining, and confirm the machining program, tool offset amount and workpiece coordinate system offset amount.

4.8 MDI Operation Mode

In the MDI operation mode, automatic operation is executed by using a program set on the setting and display unit MDI program editing screen.

Operation procedure

The MDI operation follows the memory operation.

- (1) Set data on the setting and display unit MDI program editing screen.
- (2) Using the MODE SELECT switch, select the MDI mode.
- (3) The following steps are the same as the memory operation steps. Refer to 4.7.

Operation Panel Switches in Operation Mode

5.1 Rapid Traverse Override

Use the RAPID TRAVERSE OVERRIDE switch to override the rapid traverse feedrate in automatic or manual operation.
 RAPID TRAVERSE OVERRIDE is applicable to the following:
 Automatic operation: G00, G27, G28, G29, G30
 Manual operation: Rapid traverse, reference position return, incremental feed

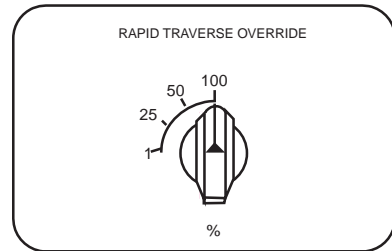

5.2 Cutting Feed Override

Use the FEED RATE OVERRIDE switch to override the feedrate in automatic operation (G01, G02, or G03 F command) or the manual feedrate of jog feed in manual operation in 10% units in the range of 0% to 300%. FEED RATE OVERRIDE is also applicable to the dry run rate in automatic operation.

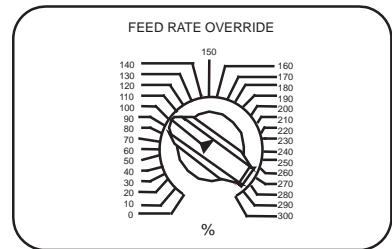

- (Note 1) The dry run rate is the movement rate set by using the MANUAL FEED RATE switch by overriding the programmed feedrate in automatic operation.
- (Note 2) Refer to the section 6.5 for feedrate override applied to manual feedrate.

5.3 Spindle Override

This function applies override to the rotation speed of a spindle or mill spindle assigned by the machining program command during automatic operation or by manual operation. There are two types of override.

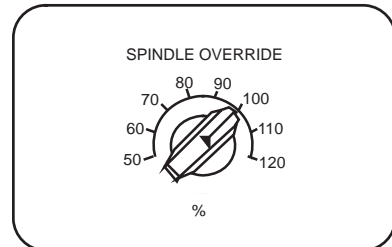

- (1) Type 1 (code method)
 Using an external signal, override can be applied to the commanded rotation speed of a spindle or mill spindle in 10% increments from 50% to 120%.
- (2) Type 2 (value setting method)
 Using an external signal, override can be applied to the commanded rotation speed of a spindle or mill spindle in 1% increments from 0% to 200%.

(Note 1) Selection between type 1 and type 2 can be designated by PLC program processing.

5.4 Manual Feedrate

Use the MANUAL FEED RATE switch to set the feedrate in jog feed mode during manual operation. The feedrate can be selected among 31 steps from 0 to 14000.0 mm/min.

When the MANUAL OVERRIDE switch (interrupt switch) is turned ON, the override value set by using the FEED RATE OVERRIDE switch takes precedence over the value set by using the MANUAL FEED RATE switch.

Manual feedrate (mm/min)				
0.	7.2	72	720	7200
1.0	10.0	100	1000	10000
1.4	14.0	140	1400	14000
2.0	20.0	200	2000	
2.7	27.0	270	2700	
3.7	37.0	370	3700	
5.2	52.0	520	5200	

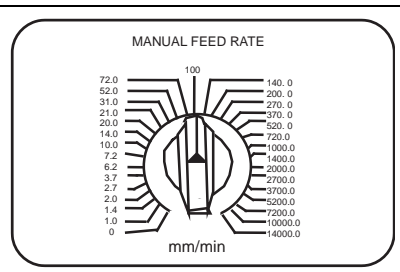

5.5 Handle/Incremental Feed Magnification

Use the HANDLE/INCREMENTAL MAGNIFICATION switch to set the travel distance commanded when manual handle feed or incremental feed is made.

The travel distances for each axis are listed below.

When B or C is set to the parameter "#1003 iunit", up to 1000 only can be validated.

Movement amount ("#1003 iunit"=B or C)	Movement amount (Other than "#1003 iunit"=B or C)
1	1
10	10
100	100
1000	1000
5000	5000
10000	10000
50000	50000
100000	100000

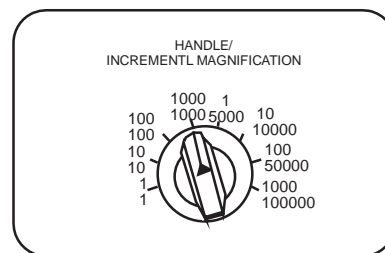

5.6 Handle Feed Axis Selection

Use the HANDLE FEED AXIS SELECT switch to select the axis moved by handle operation when the handle mode is selected.

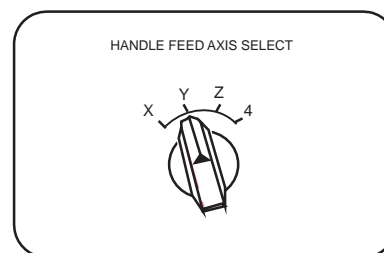

5.7 Manual Pulse Generator

In the manual handle mode, fine feed of the machine can be made by turning the manual pulse generator.

The manual pulse generator has 100 graduations per revolution and outputs one pulse per graduation. The travel distance per pulse is set by using the HANDLE/ INCREMENTAL MAGNIFICATION switch.

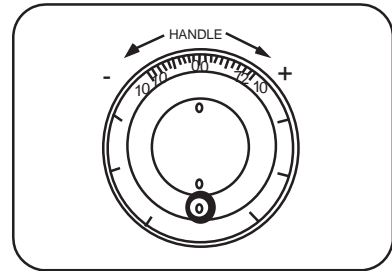

5.8 Cycle Start and Feed Hold

Use the CYCLE START switch to start automatic operation (memory, tape, or MDI). Automatic operation is executed by turning ON the switch. Use also the switch for restart from stop by the FEED HOLD switch or the automatic operation stop state.

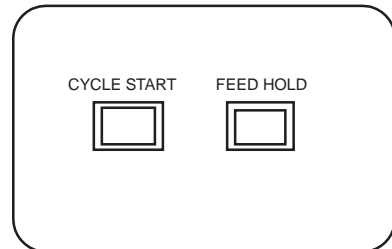

The CYCLE START switch becomes effective when the switch is turned ON, then OFF.

Use the FEED HOLD switch to temporarily stop automatic operation (for example, deceleration stop of the control axis during automatic operation). To restart operation, use the CYCLE START switch.

5.9 Feed Axis Selection

Use the FEED AXIS SELECT switch to start the controlled axis during manual operation. While the FEED AXIS SELECT switch is held ON, the selected controlled axis is moved. When the switch is turned OFF, the controlled axis movement stops.

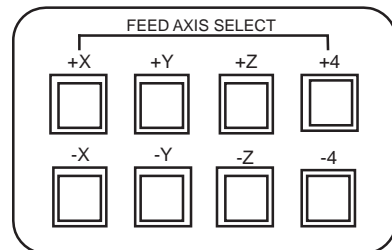

Operation Panel Switch Functions

6.1 Chamfering

Chamfering in the thread cutting cycle can be validated/invalidated using an external switch.

6.2 Miscellaneous Function Lock

- (1) M, S, T or B function execution can be ignored by turning ON the MISCELLANEOUS FUNCTION LOCK switch.
- (2) M, S, T or B function BCD output is made, but the start signal is not output.
- (3) If the MISCELLANEOUS FUNCTION LOCK switch is changed during command execution, automatic operation stops after the block being executed is terminated. Then, it becomes effective.

6.3 Single Block

- (1) When the SINGLE BLOCK switch is turned ON, automatic operation stops after the block being executed is terminated. That is, automatic operation stops after one program block is executed.
- (2) The single block stop point in the fixed cycle mode is fixed according to the fixed cycle.

6.4 Z Axis Cancel

- (1) By turning ON the "Z AXIS CANCEL" switch, NC commands can be executed for the movement by automatic operation, without moving the machine in the Z axis only.
The Z axis does not move, but the current position display of the setting display unit is incremented.
- (2) The Z axis moves by manual operation even when the "Z AXIS CANCEL" switch is turned ON.
- (3) If the "Z AXIS CANCEL" switch is changed over during automatic operation, the new switch setting is validated when the automatic operation stops after the block being executed finishes.
- (4) In reference position returns (G28, G30), the axis is controlled to the middle point in a canceled Z axis state, but this state is ignored after the middle point.

6.5 Dry Run

- (1) When the DRY RUN switch is turned ON, the feedrate set by using the MANUAL FEED RATE switch takes precedence over the programmed feedrate (F).

6.6 Manual Override

- (1) When the MANUAL OVERRIDE switch is turned ON, the override value set by using the FEED OVERRIDE switch takes precedence over the value set by using the MANUAL FEED RATE switch.
- (2) The override value set by using the FEED OVERRIDE switch also takes precedence over the dry run during automatic operation.
- (3) Manual override becomes effective immediately when the switch is turned ON.

6.7 Override Cancel

- (1) When the OVERRIDE CANCEL switch is turned ON, the programmed F command value takes precedence over the override value set by using the FEED RATE OVERRIDE switch.
- (2) It is not effective for manual override.

6.8 Optional Stop

- (1) If M01 is programmed, the machine automatically stops by turning ON the OPTIONAL STOP switch. When the switch is OFF, M01 is ignored and the machine does not stop.
- (2) The machine stops after the M01 block is executed.

6.9 Optional Block Skip

When the OPTIONAL BLOCK SKIP switch is turned ON, a section of a block that follows a "/" (slash) is skipped; when the switch is OFF, the block is executed. This enables the operator to specify whether or not a section of a block that follows a "/" code is executed.

A block which has a "/" code in not the head but the middle is operated according to the parameter "#1226 aux10/bit1 (optional block skip type)" setting.

0: Enable only at the beginning of a block.

1: Enable in the middle of a block, as well as at the beginning of the block.

(Example)When machining two parts as illustrated below, if the following program is prepared and the machining is done by turning ON the OPTIONAL BLOCK SKIP switch, part (a) is provided; if the machining is done by turning OFF the switch, part (b) is provided:

Program

```

N1 G54 ;
N2 G90 G81 X50. Z-20. R3. F100 ;
/5 N3 X30. ;
N4 X10. ;
N5 G80 ;
M02;

```

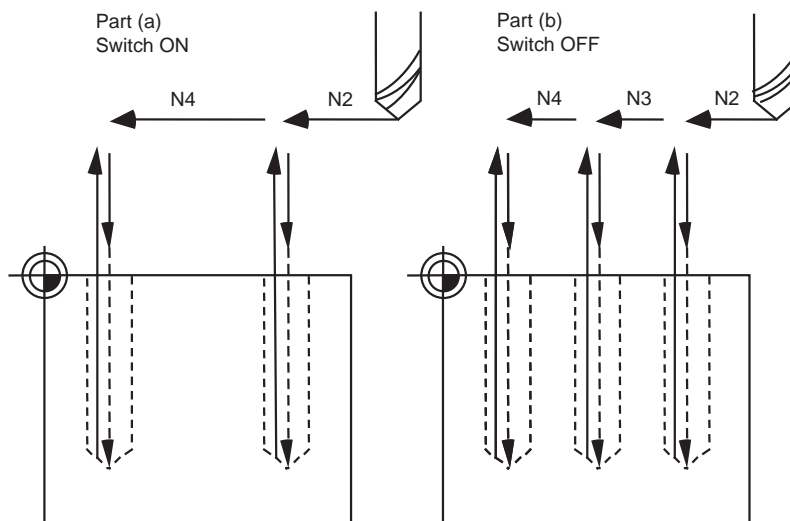

Operation of a block which has a "/" in the middle, not at the head, depends on the setting of parameter "#1274 ext10/bit4 (Optional block skip operation changeover)".

0: Follows the setting of "#1226 aux10/bit1".

1: Enable optional block skipping at the top and in the middle of a block.

Note that a slash "/" on the right-hand side of equation is handled as division operator.

6.10 Manual Absolute

When the MANUAL ABSOLUTE switch is turned ON, while the program coordinate system is not updated, the coordinate position is updated by the distance in which the tool has been moved manually. If the switch is OFF, the program coordinate system is updated when the tool is manually moved.

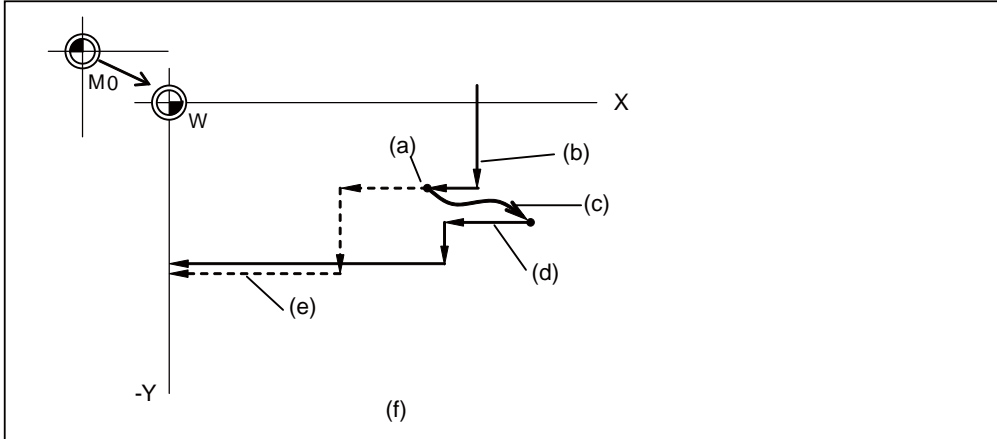

- (a) Feed hold stop
- (b) Programmed path (absolute command)
- (c) Manual interrupt (The coordinate system W is not shifted)
- (d) Path after manual interrupt
- (e) Tool passes along same path as that programmed
- (f) With manual absolute signal ON

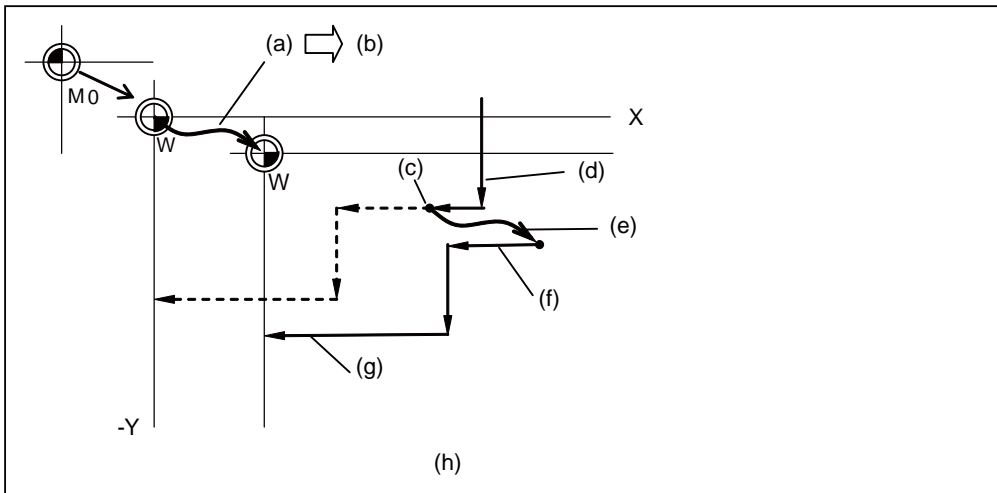

- (a) Manual interrupt (The coordinate system W is shifted)
- (b) Manual interrupt amount
- (c) Feed hold stop
- (d) Programmed path (absolute command)
- (e) Manual interrupt (The coordinate system W is shifted)
- (f) Path after manual interrupt
- (g) Path is shifted by an amount equivalent to manual interrupt value (Zero point of the coordinate system W moves)
- (h) With manual absolute signal OFF

6.11 Mirror Image

When cutting a shape having bilateral symmetry, this function can be used to machine either the right or left side of the shape from the program for the other side, thus saving programming time. When cutting a shape having upper and lower symmetry, this function can be used to machine either the upper or lower side of the shape from the program for the other side.

The mirror image function is effective in this case.

For example, when there is a program for machining the left side of the shape shown in the following drawing, a symmetrical shape to the left side shape can be machined on the right side by applying the mirror image function and running the same program.

Be sure the machining program starts and finishes at the mirror center.

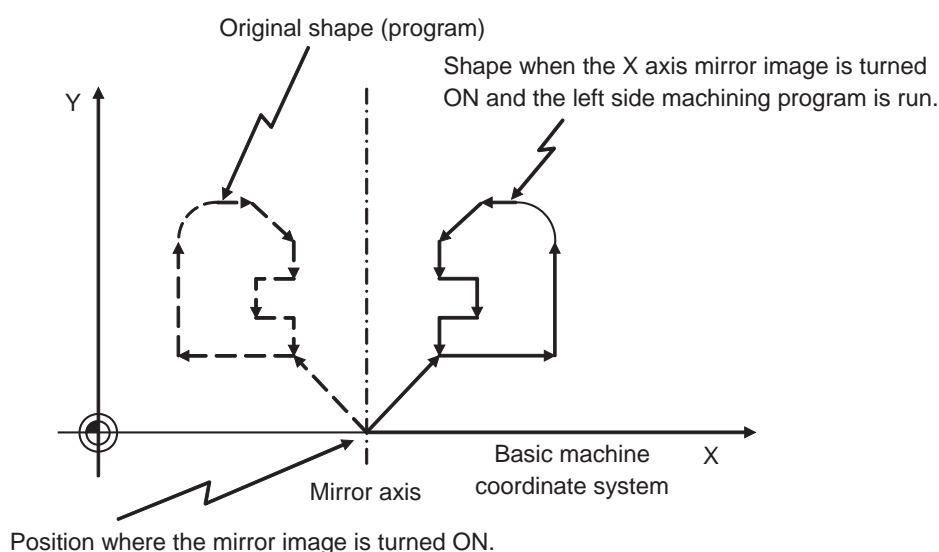

Mirror image includes external input mirror image, parameter setting mirror image, programmable mirror image, etc. Only program mirror image function can be used in E70 series. (M system only)

Refer to the Programming Manual for information on programmable mirror image.

6.12 Error Detect

For positioning (G00), machine deceleration check is made before next block movement is started. For cutting (G01, G02, or G03), the next block is started before the machine reaches the movement command end point. Thus, the corner part is slightly rounded.

To prevent rounded corners, turn ON the error detect signal. This will cause the machine to decelerate until the remaining distance falls below the value of the parameter. The next block command is stopped during this time.

This function is equivalent to G09 in the program.

The parameter that is used by the error detect switch and the G09 command for determining the remaining distance after

deceleration for moving to the next command can be set with the setting and display unit.

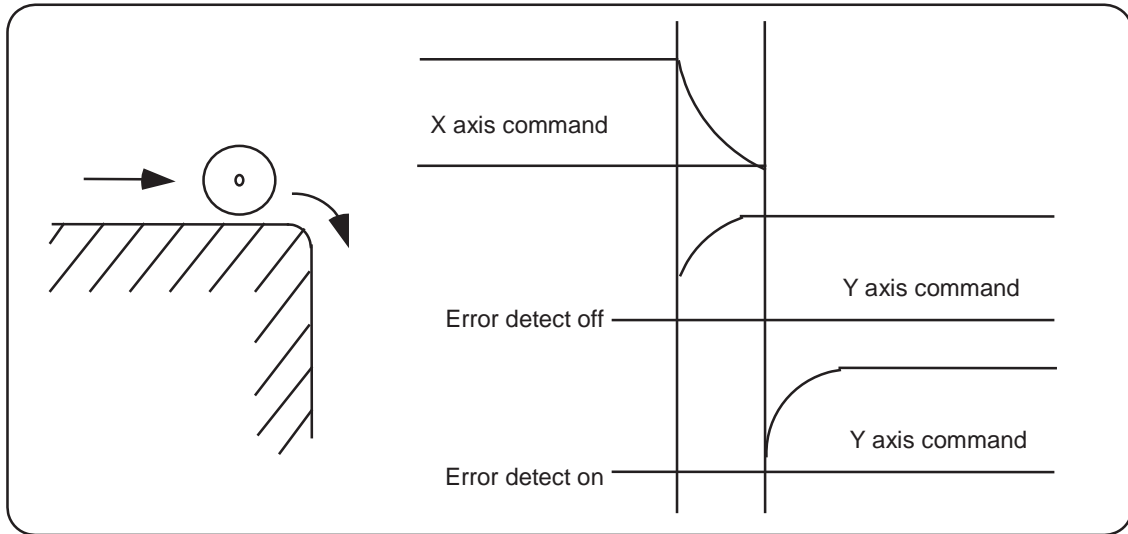

6.13 Follow-up Function

The follow-up function monitors machine motion in the emergency stop state and reflects it in the current position and workpiece coordinates. Thus, the work program can be continued without re-executing a reference position return after emergency stop.

6.14 Axis Removal

When the machine receives the axis removal signal, that axis no longer becomes the controlled axis. Accordingly, the alarm related with axis, such as the stroke end axis, and the servo alarms (excessive errors, lack of signal, drive alarm, etc.) will be ignored. At the same time, the axis will become interlocked.

(Note) This cannot be used for the absolute position detector specification axis.

6.15 F 1-digit Feed

6.15.1 Outline

The feedrate registered by parameter can be assigned by designating a single digit following address F.

There are six F codes: F0 and F1 to F5. The rapid traverse rate is applied when F0 is issued which is the same as the G00 command.

When one of the codes from F1 to F5 is issued, the cutting feedrate set to support the code serves as the valid rate command.

If F6 or larger value is command, the value is regarded as the cutting feedrate which has been directly commanded with numerical values.

When an F1-digit command has been issued, the external output signal is output.

When "F1-digit speed change valid" signal is valid when F1-digit feed is issued, a feedrate which is set by a parameter can be increased or decreased by operating the manual handle.

6.15.2 Detailed Description

- (1) When the programmed feedrate has been issued as an F 1-digit command, the feedrate can be increased or reduced by turning the manual handle when turning ON the "F 1-DIGIT FEED" switch. The feedrate cannot be changed by the 2nd and 3rd handles.

- (2) The increase/decrease amount per handle gradient is expressed with the following equation.

$$\Delta F = \Delta P \times \frac{FM}{K}$$

ΔP : Handle pulse (\pm)

FM : Upper limit of F 1-digit feedrate (#1506 F1_FM)

K : F 1-digit feedrate change constant (#1507 F1_K)

(Example) For a 10mm/min. increase/decrease amount per handle gradient:

If F max = 3600mm/min :

$$\Delta F = 10 = 1 \times \frac{3600}{K} \quad \text{Thus, } K = 360.$$

- (3) The acceleration/deceleration method follows the rapid traverse setting when F0 is issued. But G modal does not change.
- (4) F1-digit feed command is valid in a G01, G02, G03, G02.1 or G03.1 modal.
- (5) F1-digit feed command can be used for fixed cycle.
- (6) F1-digit feed command is a modal command.
- (7) The number of manual handle pulses is 1 pulse per scale unit regardless of the scaling factor.
- (8) During a F1-digit feed command, the F1-digit feed number and F1-digit feed command signal are output as the PLC signals.

The conditions for validation of the speed change with the handle

The conditions for validation are as follows:

- (1) The operation must be in automatic start.
- (2) The operation must be in cutting feed, and F 1-digit feedrate command must be issued.
- (3) The F 1-digit feed parameter must be ON.
- (4) The F 1-digit feed switch must be ON.
- (5) The operation must not be in machine lock.
- (6) The operation must not be in dry run.
- (7) Upper limit of F1-digit feedrate ("#1506 F1_FM") and F1-digit feedrate change constant("#1507 F1_K F1") are not zero.

Conversion of the F1-digit feedrate changing with handle operation

Once the F1-digit feedrate is changed with manual handle, the changed feedrate is valid until parameter is changed or the power is turned OFF. Changed feedrate can be checked only during the operation. Note that if the parameter "#1246 set18/bit16" (switch over of the F1-digit feedrate changing method) is set to "1", even after the power is turned OFF, operation is kept at the changed feedrate because the parameter of F1-digit feedrate has been changed. In this case, if the screen is not switched, the changed parameter values are not reflected to the display.

- (Note 1) If F1-digit feedrate changing valid signal is turned ON when F1-digit feed is commanded and changing feedrate with the manual handle is valid, it is clamped at the upper limit of F1-digit feedrate if the F1-digit feedrate is greater than the upper limit of F1-digit feedrate.
- (Note 2) When the F1-digit feedrate is 0 with the handle operation during the F1-digit feedrate command, the alarm "M01 F1-digit feed rate zero 0104" will occur. This alarm can be eliminated when the F1-digit feedrate is set in larger value than 0 with the handle operation.
- (Note 3) When K is 0, the speed is not changed.

6.15.3 Preautions

- (1) When G00 mode is applied, F1 to F5 are invalid in the G00 mode and the rapid traverse rate is established instead.
- (2) If F0 is used in the G02, G03, G02.1 or G03.1 mode, a program error (P121) will occur. The error will be eliminated if the F0 command is rewritten.
- (3) When F1. to F5. (with decimal point) are assigned, the 1mm/min to 5mm/min (direct numerical value command) are established instead of the F1-digit feed command.
- (4) When the commands are used with inch command, one-tenth of the feedrate set correspond to F1 to F5 serves at the assigned speed inch/min.
- (5) When the commands are used with the millimeter or degree units, the feedrate set to correspond to F1 to F5 serves as the assigned speed mm (°)/mm.
- (6) Even if the F1-digit feed is commanded during feed per revolution (G95), it is executed as a normal F command (direct numerical value command).
- (7) When both the F1-digit feed command and inverse time feed command are present, the inverse time feed command will have the priority.
- (8) When both the F1-digit feedrate changing and the manual speed command are present, the manual speed command will have the priority.
- (9) In the synchronous tapping command, the speed cannot be changed with the handle.

6.16 Manual/Automatic Synchronous Feed

6.16.1 Outline

Using this function, a random axis can be moved with manual operation even while another axis is moving with automatic operation. One automatic operation mode and one manual operation mode are selected with the PLC program and the axis to be moved with manual operation is selected. (This axis is hereafter called the "manual/automatic simultaneous valid axis".)

If the axis being moved with automatic operation is selected as the manual/automatic simultaneous valid axis, or if a movement command is issued with automatic operation to an axis already selected as the manual/automatic simultaneous valid axis, interlock will be applied on the movement by automatic operation, and the movement with manual operation will have the priority.

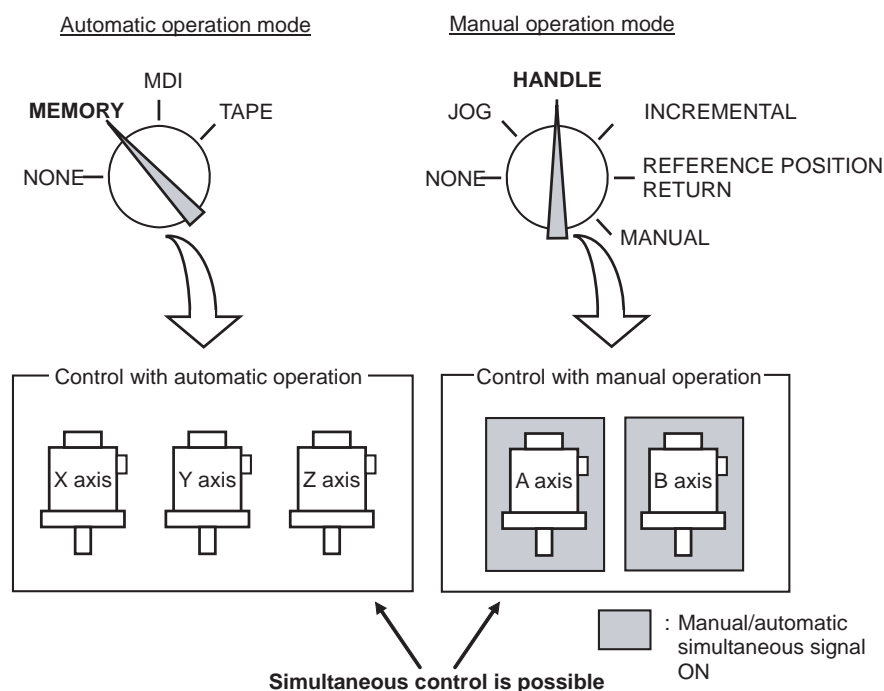

6.16.2 Conditions for Validating Manual/Automatic Synchronous Feed

This function is valid when the following conditions are established.

- One automatic operation mode and one manual operation mode are selected. (The manual operation mode can be selected during automatic operation.)
- The manual/automatic simultaneous valid axis is selected. (The "Manual/Automatic simultaneous valid n-th axis" signal is ON for the axis to be controlled with manual operation.)

The manual/automatic simultaneous valid axis (axis for which "Manual/Automatic simultaneous valid n-th axis" signal is ON) can be controlled with the selected manual operation mode.

6.16.3 Operation during manual/automatic simultaneous operation

- (1) The manual operation and automatic operation feedrates are independent. The acceleration/ deceleration mode (rapid traverse/cutting feed) and time constants are also independent.
- (2) The rapid traverse override is valid for both automatic operation and manual operation. The cutting feed override and 2nd cutting feed override are valid only for automatic operation.
However, these will also be valid during manual operation if the manual override method selection signal is ON. Override cancel is valid only for automatic operation.
- (3) Manual interlock is valid for the manual/automatic simultaneous valid axis, and automatic interlock is valid for the axis in automatic operation.
- (4) Manual machine lock is valid for the manual/automatic simultaneous valid axis, and automatic machine lock is valid for the axis in automatic operation.
- (5) The signals in cutting feed and in rapid traverse will follow the automatic operation movement mode.
- (6) Movement of the manual/automatic simultaneous valid axis will not stop with the single block stop or feed hold stop.
- (7) If the manual/automatic simultaneous valid axis reaches the stored stroke limit or stroke limit, the axis moving in automatic operation will also stop immediately, and the feed hold state will be entered. In this case, automatic operation can be restarted by canceling the stored stroke limit or stroke limit with manual operation.
- (8) Even if the handle mode is selected for the manual operation mode, the manual/automatic simultaneous function will be the priority for the axis for which the "Manual/Automatic simultaneous valid n-th axis" signal is ON.
- (9) The speed display indicates the following speeds according to the parameter "#1125 real_f".

Function	#1125 real_f	
	1	0
Manual/automatic simultaneous operation	Composite manual and automatic speeds (The actual feedrates are independent.)	Automatic F command speed priority (Manual command speed when there is no axis moving with automatic operation)
Only manual operation	Manual actual feedrate	Manual command speed
Only automatic operation	Automatic actual feedrate	Automatic F command speed

6.16.4 Operation When Automatic Operation Commands and Manual/Automatic Simultaneous Valid Selection are Issued for Same Axis

- (1) If a movement command with automatic operation is issued to a manual/automatic simultaneous valid axis, the alarm "Internal interlock axis exists" will occur. Automatic operation will stop in the interlock state until the "Manual/Automatic simultaneous valid n-th axis" signal turns OFF. The manual/automatic simultaneous valid axis can be controlled in the manual operation mode during this time.

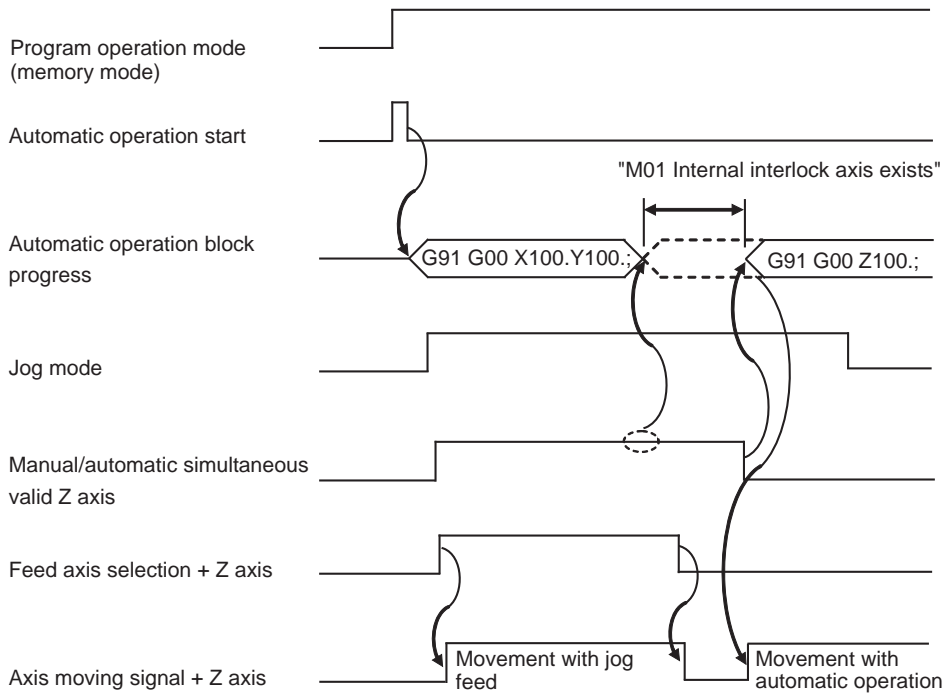

6 Operation Panel Switch Functions

- (2) If the "Manual/Automatic simultaneous valid n-th axis" signal is turned ON for an axis moving with automatic operation, the alarm "Internal interlock axis exists" will occur, and the operation will decelerate to a stop immediately. Automatic operation will stop in the interlock state until the "Manual/Automatic simultaneous valid n-th axis" signal turns OFF. The manual/automatic simultaneous valid axis can be controlled in the manual operation mode during this time.

Note that the interlock will be applied even during a tap modal.

Interlock will also be applied during synchronous tap cutting, and the spindle will also be synchronized to the manual drilling axis.

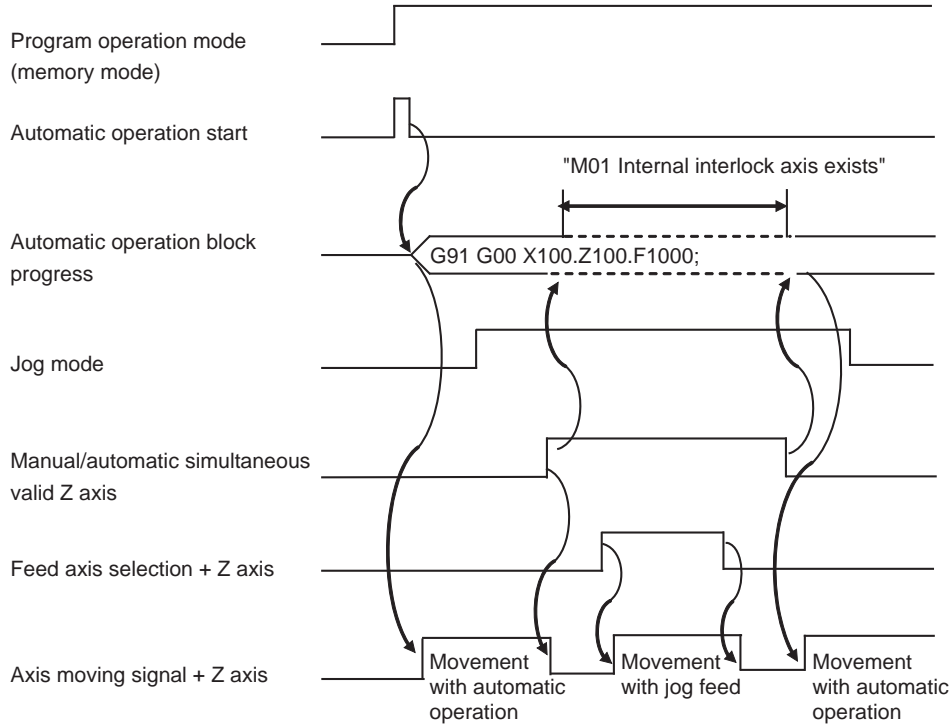

- (3) When the manual/automatic simultaneous valid axis is moving by manual, the G92 command from the automatic operation will be executed after the axes, including this axis, have stopped.
- (4) When several axes are interpolated and moving with automatic operation, all axes will stop if the "Manual/Automatic simultaneous valid n-th axis" signal turns ON for even one axis. When moving the axes independently such as during automatic reference position return, or during rapid traverse when the parameter "#1086 G00 non-interpolation" is ON, only the axis for which the "manual/automatic simultaneous valid" signal is ON will stop.
- (5) The interlock will not be applied even if the "Manual/Automatic simultaneous valid n-th axis" signal is turned ON for the virtual axis in virtual axis interpolation.
- (6) If the "Manual/Automatic simultaneous valid n-th axis" signal is turned ON for an axis moving with the automatic operation's G90 modal or G53 command and the manual/automatic simultaneous valid axis is moved manually, when the "Manual/Automatic simultaneous valid n-th axis" signal turns OFF, the end point of automatic operation will be deviated by the amount the axis was moved manually. During the G90 modal, the command path will be returned to during the next block.
- (7) If the "Manual/Automatic simultaneous valid n-th axis" signal is turned ON for an axis during reference position return and the axis is manually moved, the reference position return operation will be executed again. When the reference position is reached manually, the interlock will be released, and the block will end. Manual operation after the block is completed will follow the manual operation block.

6.16.5 Other Precautions

- (1) If only the automatic operation mode is selected and the manual operation mode is not selected, the "Manual/Automatic simultaneous valid n-th axis" signal will be invalid.
- (2) Even if one automatic operation mode and one manual operation mode are selected, valid manual operation to an axis for which the "Manual/Automatic simultaneous valid n-th axis" signal is turned OFF is limited to handle-feed interruption only.
- (3) If the "Manual/Automatic simultaneous valid n-th axis" signal is ON for the 1st and 2nd axes and the "Circular feed in manual mode valid" signal is turned ON during automatic operation, the manual arc feed will not be validated. If automatic operation is attempted while manual arc feed is valid, the manual arc feed will be invalidated even if the "Manual/Automatic simultaneous valid n-th axis" signal for the 1st and 2nd axes is ON. In this case, none of the axes can be moved with manual operation until the "Circular feed in manual mode valid" signal is turned OFF.
- (4) The "Manual/Automatic simultaneous valid n-th axis" signal is invalid for the chopping axis during chopping.
- (5) Manual random feed will not be executed if even one axis other than the manual/automatic simultaneous valid axis is set as the manual random feed axis. Note that only the manual/automatic simultaneous valid axis is executed during non-interpolation.
- (6) When the manual mode is selected for the manual/automatic simultaneous valid axis while moving in the automatic high-accuracy mode, if the axis is moved manually before the automatic operation decelerates to a stop with the interlock, the speed may change in steps when the manual movement is started. Start manual operation after the automatic operation has decelerated to a stop.

6.17 Handle Interruption

6.17.1 Outline

Section 6.14 explains automatic handle interruption, which enables the operator to interrupt movement using the manual handle in automatic modes (tape, memory, MDI).

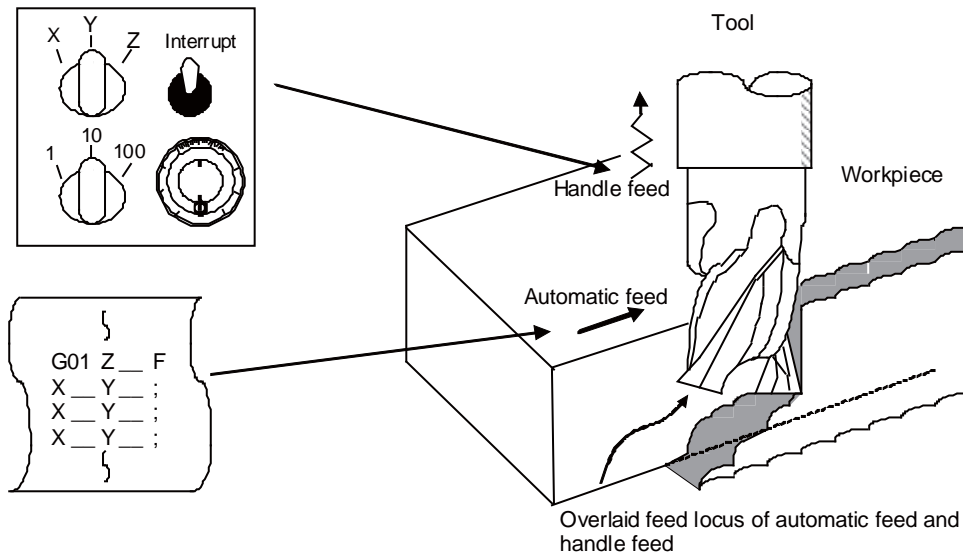

6.17.2 Interruptible Conditions

- (1) The automatic handle interrupt function allows you to interrupt the program manually by selecting the manual handle mode in automatic mode selection (tape, memory, MDI, etc.). However the interrupt cannot be executed by the manual handle when an automatic reference position return command (G28, G29, G30), the thread cutting (G33), or the skip command (G31) has been executed or when tapping in the tapping cycle.
- (2) If automatic operation mode such as tape, memory, or MDI is being selected even when an automatic operation pause (including a block stop) is established, automatic handle interruption is enabled.
- (3) If the axis is moved during dwell (G04) command processing by using automatic handle interruption, the dwell count operation will stop. A check is made for the completion of the axis movement, then the dwell count operation continues.
- (4) Automatic handle interruption is enabled even if automatic machine lock has been set. If manual machine lock has been set, the machine does not move; it only updates the POSITION display. If manual machine lock has not been set, the machine moves by the interruption distance by the manual handle and the POSITION display is updated.
- (5) This function is disabled for an axis to which the interlock signal has been input or an axis of which interruption direction is the soft limit.

6.17.3 Interruption Effective Axis

- (1) Automatic handle interruption is enabled only for axes to which manual handle axis selection has been input.
- (2) Automatic handle interruption is enabled for a maximum of three axes. (The number of axes is restricted by the number of handles.)

6.17.4 Axis Movement Speed Resulting From Interruption

- (1) The movement speed (Automatic-start movement speed + Speed resulting from manual handle interruption.) of the axis for which handle interruption is executed, may exceed the rapid traverse feed rate during rapid traverse feed command (G00) processing in automatic start. To prevent this, clamp the axis.
- (2) The movement speed (Automatic start movement speed + Speed resulting from manual handle interruption.) of the axis for which handle interruption is executed, may exceed the cutting feed speed during cutting feed command (G01, G02, G03) processing in automatic start. To prevent this, clamp the axis.
- (3) If, during automatic start, manual handle interruption is executed in the same direction for the axis that is moving at an external decelerating speed, the axis movement speed (Automatic start movement speed + Speed resulting from manual handle interruption.) may exceed the external decelerating speed. To prevent this, clamp the axis.
- (4) If an attempt is made to execute interruption at a speed exceeding the clamp speed, the reading on the handle scale does not match the distance of interruption.
- (5) The handle scale factor depends on the selected input of the manual handle/step scale factor.

6.17.5 Path Resulting After Handle Interruption

(1) For incremental (G91) mode

The locus deviates from the program path by the distance of interruption. (See the figure below.)

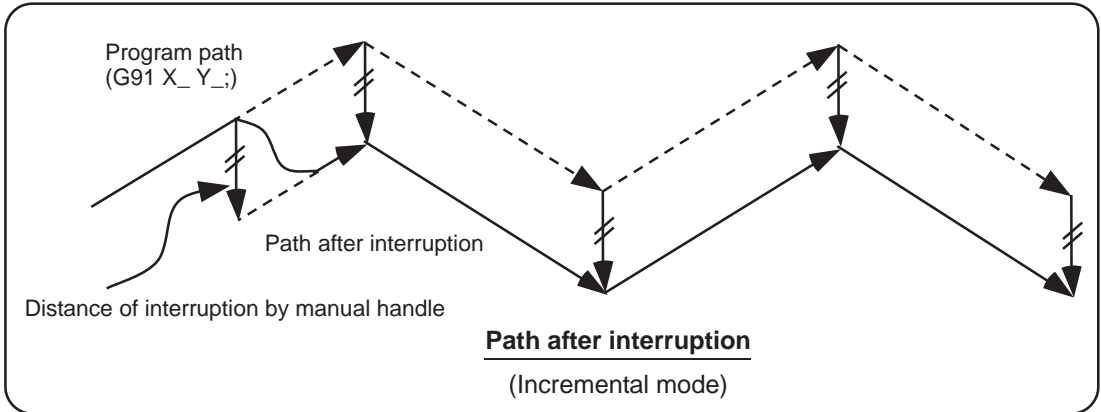

(2) For absolute (G90) mode

If program absolute position update by the distance of handle interruption is disabled, the locus deviates from the program path by the distance of interruption.

If this update is enabled, the locus returns to the program path during processing of the following command:

For single block running - Return command is issued in the block next to the one for which the interruption has been completed.

For continuous running - Return command is issued in the third block, if the block for which the interruption has been completed is the first block.

(Note) Both POSITION and MACHINE display include the distance of handle interruption.

For automatic handle interruption, select whether absolute mode is updated or not, as follows:

- (a) Using machine parameters, set whether the manual absolute changeover switch or parameters are used.
- (b) If the parameters are used, set whether or not absolute position data is updated for each axis, by using machine parameters other than those in item.
- (c) If the manual absolute changeover switch is used, use the machine operation panel switch for selection.

Absolute position update conditions for automatic handle interruption

			Absolute data update		Absolute data update
Parameter #1145 I_abs	ON "1"	Parameter "#1061intabs" (Every axis)	ON "1"	Absolute position is updated.	Not updated.
			OFF "0"	Absolute position is not updated.	Updated.
	OFF "0"	PLC interface manual absolute switching	ON	Absolute position is updated.	Not updated.
			OFF	Absolute position is not updated.	Updated.

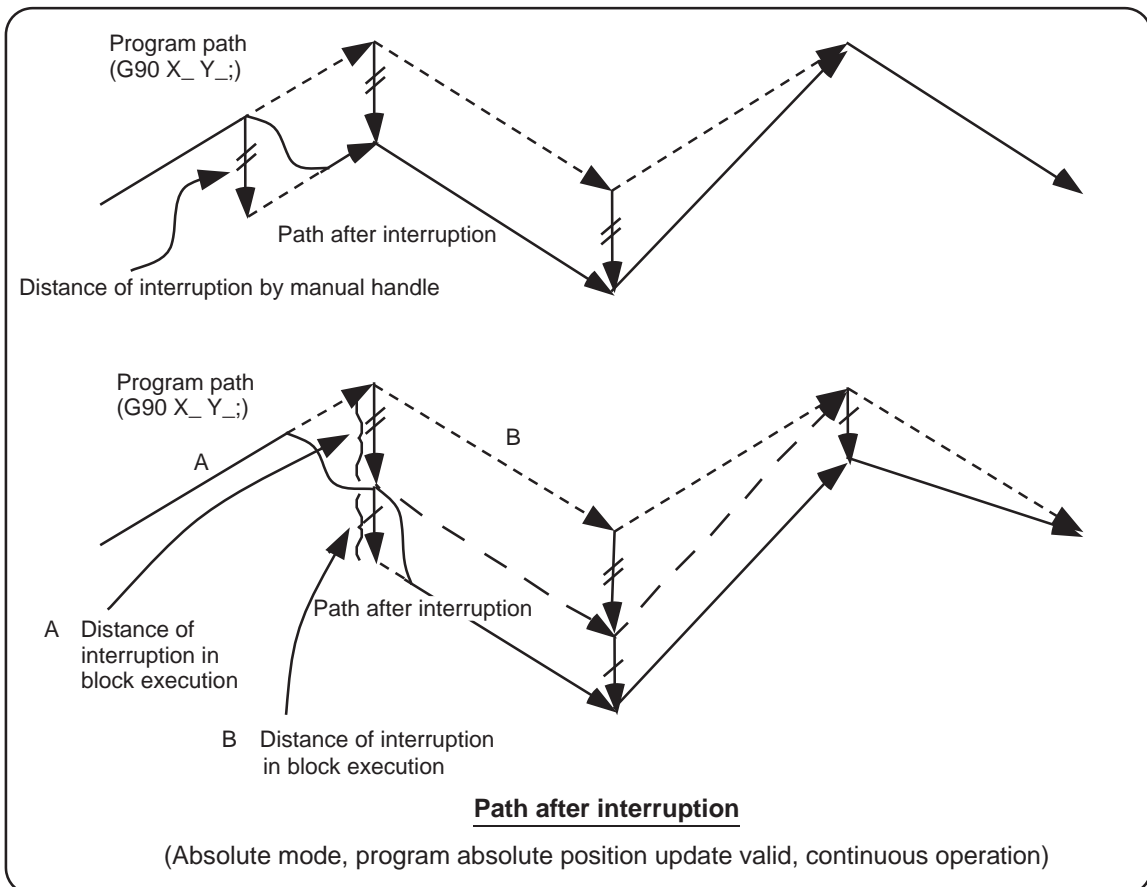
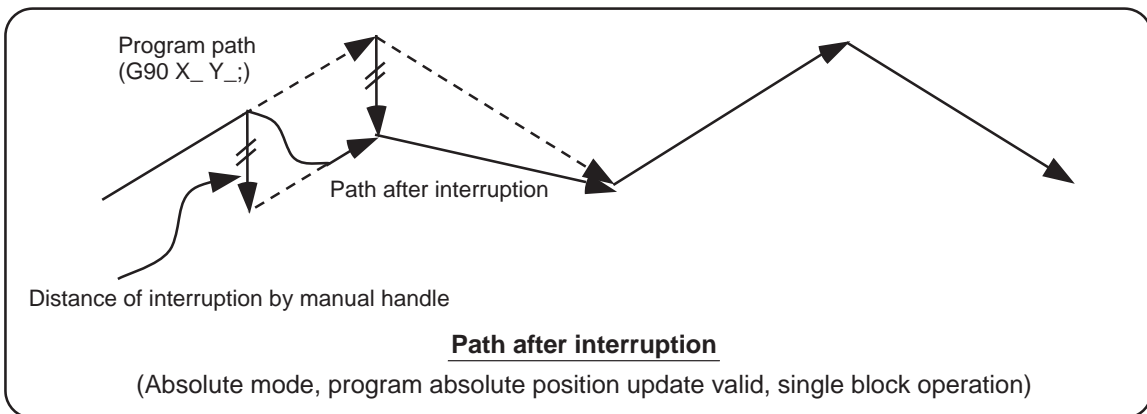
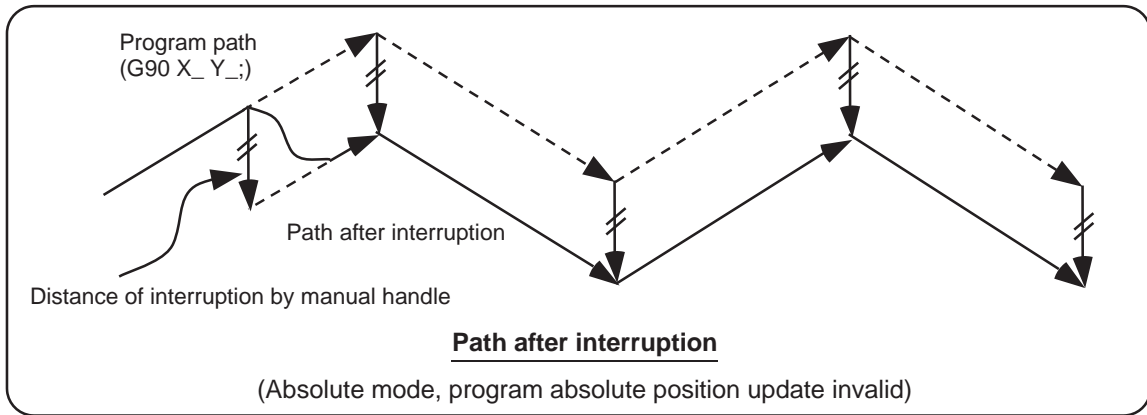

6.17.6 Handle Interruption in Tool Radius Compensation

Special movement described below relates only to the tool radius compensation plane axis. It has no influence on the other axes.

At time of tool radius compensation (G41, G42):

In incremental mode (G91) - The quantity of deviation equals the distance of interruption.

In absolute mode (G90) - If handle interruption is executed in the block for which tool radius compensation (G41, G42) is being executed, the proper tool path will return in the succeeding block. This rule applies only when the program absolute position update is valid during single block running. If program absolute position update is valid during continuous running, the proper tool path will return at the fourth block after the one where the interruption has been completed.

If there is no G block existed between the block where the interruption has been completed and the block that contains the tool radius competition cancel command (G40), the proper tool path will return at the block next to the tool radius compensation cancel command (G40).

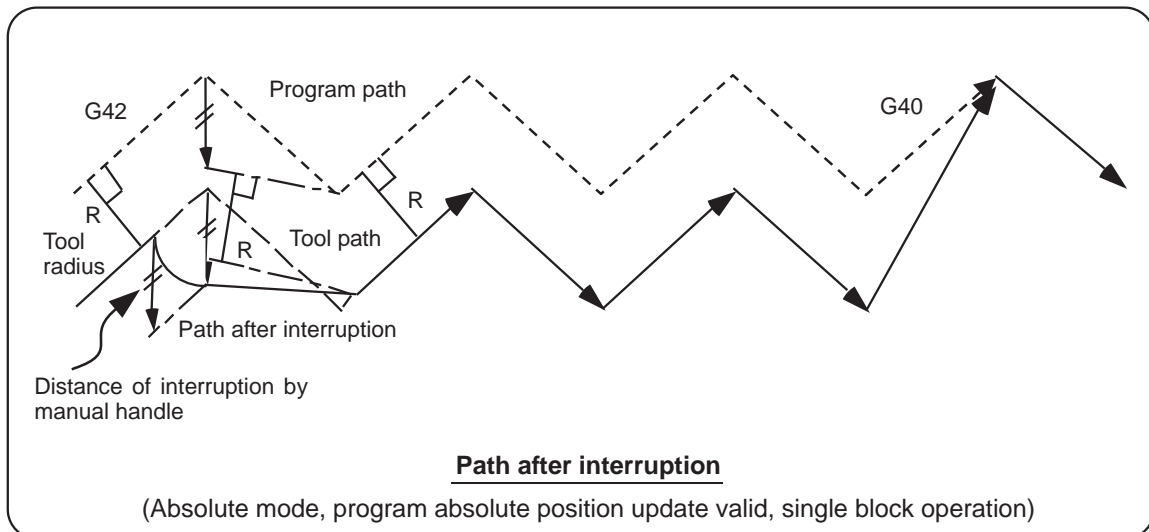
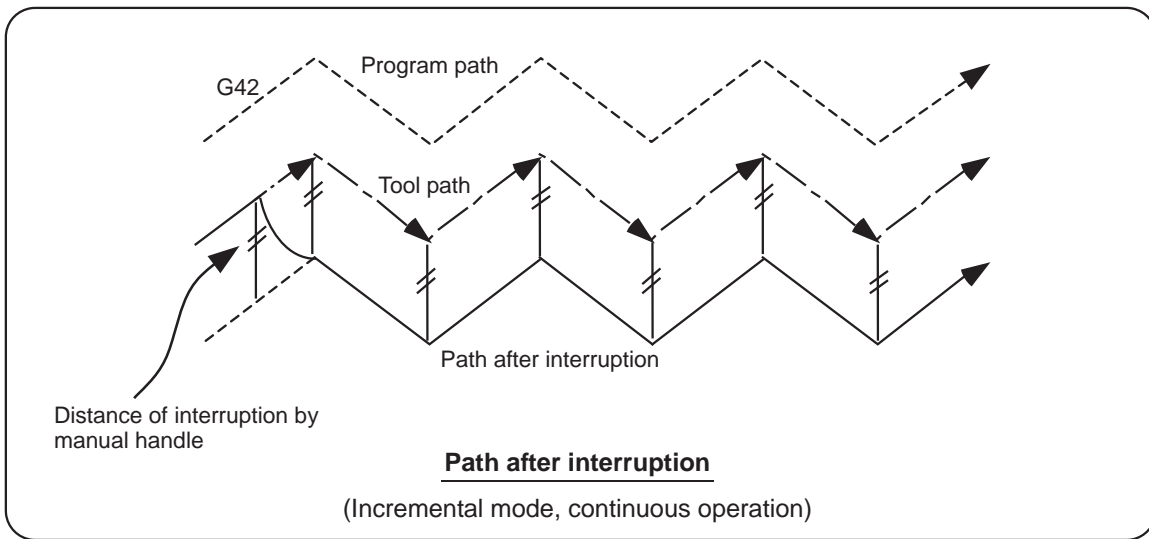

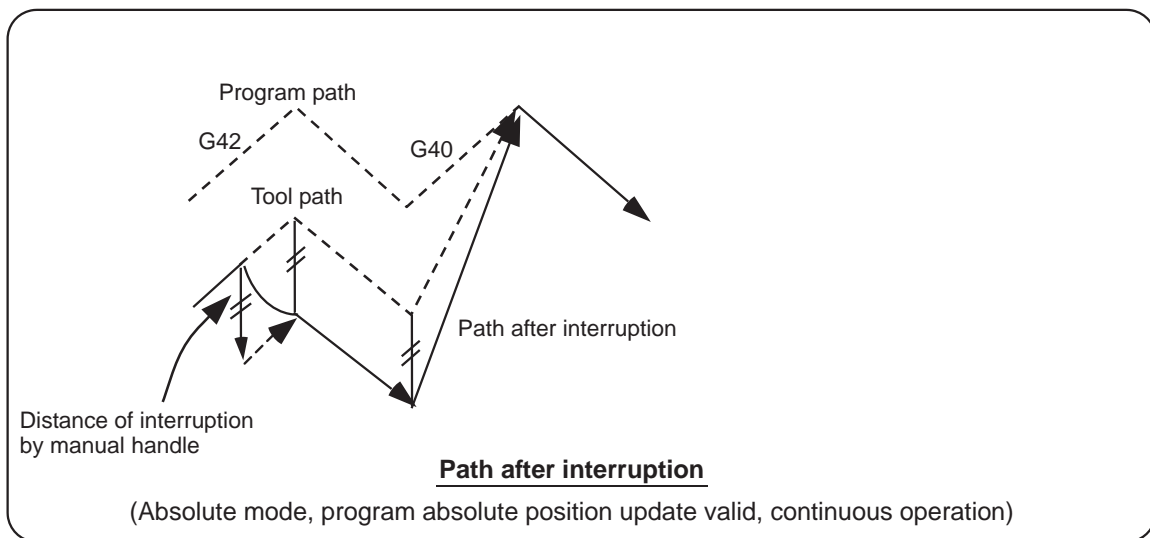
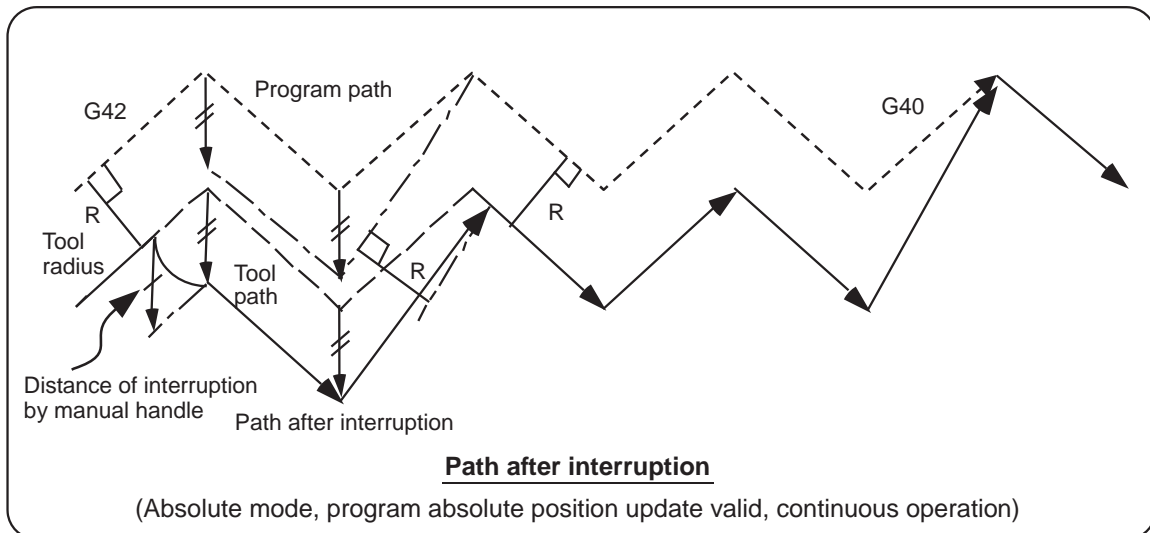

6.17.7 Interrupt Amount Reset

Interrupt amount is reset when

- (1) Dog reference position return is executed;
- (2) Emergency stop is released;
- (3) Reset rewind or reset 2 is executed; or
- (4) Reset 1 is executed when the setup parameter "#1151 rstint" is ON.

6.17.8 Operation Procedure

An operation example is given on the assumption that auto operation of XYZ axes is executed in the memory operation mode and the Z axis is used as a handle interrupt axis.

Perform automatic operation.

Turn ON the HANDLE INTERRUPT switch on the machine operation panel.

Select interrupt axis by setting the HANDLE AXIS SELECTION switch on the machine operation panel.
 Select the travel distance per handle graduation by setting the HANDLE/INCREMENTAL MAGNIFICATION switch.

Turn the manual handle in the + or - direction and change the Z axis cut depth amount.

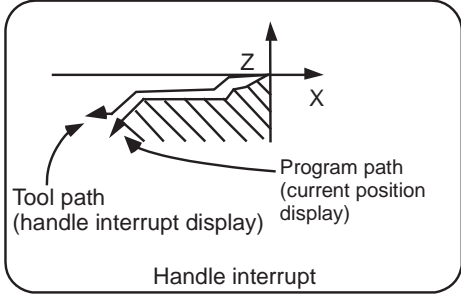
When M02 or M30 is executed, automatic operation will stop.

6.18 All Axis Machine Lock

- (1) When the "ALL AXES MACHINE LOCK" switch is turned ON, the NC commands for the manual operation or automatic operation movement can be executed without moving the machine.
The current position display on the setting and display unit will be counted.
- (2) The feedrate in the machine lock status is the command speed.
- (3) If the "ALL AXES MACHINE LOCK" switch is changed during automatic operation, the automatic operation will stop after the block currently being executed is completed, and then the setting will be validated.
- (4) During reference position return (G28, G30), the movement will be controlled with the machine lock status up to the middle point. The machine lock status will be ignored from the middle point to the reference position.
- (5) If the "MACHINE LOCK" switch is changed during manual operation, the setting will be validated after the feed is stopped once.
- (6) The M, S, T and B commands are executed according to the program.
- (7) When the "MACHINE LOCK" is turned OFF after the axis is moved in the "MACHINE LOCK" ON state, the current position display and the machine position will not match.
If AUTO START is pressed in this state, the difference between the current position and the machine position will be added to the movement amount.
If RESET is pressed, the current position display will be changed to match the machine position. Thus, after turning "MACHINE LOCK" OFF, press RESET before starting operation.

6.19 Each Axis Machine Lock

By turning ON the "MACHINE LOCK" switch provided for each axis, machine lock will be applied only on the control axis (axes) turned ON. All matters, other than the machine lock for each axis, are the same as all axes machine lock.

6.20 Deceleration Check

6.20.1 Functions

The purpose of the deceleration check is to reduce the machine shock that occurs when the control axis feedrate is suddenly changed, and prevent corner roundness. The check is carried out at block joints.

(1) Deceleration check during rapid traverse

The deceleration check is always carried out at the block joints (before executing the next block) during rapid traverse.

(2) Deceleration check during cutting feed

The deceleration check is carried out at the block joints (before executing the next block) during cutting feed when any one of the following conditions is valid.

- (a) When the error detect switch is ON.
- (b) When G09 (exact stop check) is commanded in the same block.
- (c) When G61 (exact stop check mode) has been selected.

(3) Designating deceleration check

The deceleration check by designating a parameter includes "deceleration check specification type 1" and "deceleration check specification type 2". The setting is selected with the parameter "#1306 InpsTyp".

(a) Deceleration check specification type 1 ("#1306 InpsTyp"= 0)

The G0 and G1 deceleration check method can be selected with the base specification parameter deceleration check method 1 "#1193 inpos" and deceleration check method 2 "#1223 aux07/bit1".

Parameter Inpos (#1193)	Rapid traverse command G0 → XX (G0+G9 → XX)	Parameter AUX07/BIT-1 (#1223/BIT-1)	Other than rapid traverse command (G1 : other than G0 command)	
			G1+G9 → XX	G1 → XX
0	Command deceleration check	0	Command deceleration check	No deceleration check
1	In-position check	1	In-position check	

(Note) XX expresses all commands.

(b) Deceleration check specification type 2 ("#1306 InpsTyp"= 1)

Rapid traverse and cutting feed in-position are designated with the parameter "#1193 inpos".

Parameter #1193 inpos	Command block		
	G0	G1+G9	G1
0	Command deceleration check	Command deceleration check	No deceleration check
1	In-position check	In-position check	No deceleration check

(Note) "G0" means the rapid traverse, and "G1" means the cutting feed.

6.20.2 Deceleration Check Method

(1) Command deceleration check

After interpolation for one block has been completed, the completion of the command system deceleration is confirmed before execution of the next block.

The time required for the deceleration check is determined according to the acceleration/deceleration mode and acceleration/deceleration time constant.

(a) For linear acceleration/deceleration

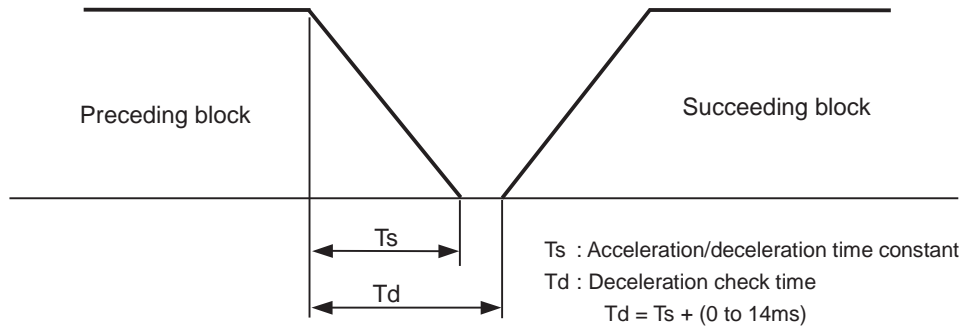

(b) For exponential acceleration/deceleration

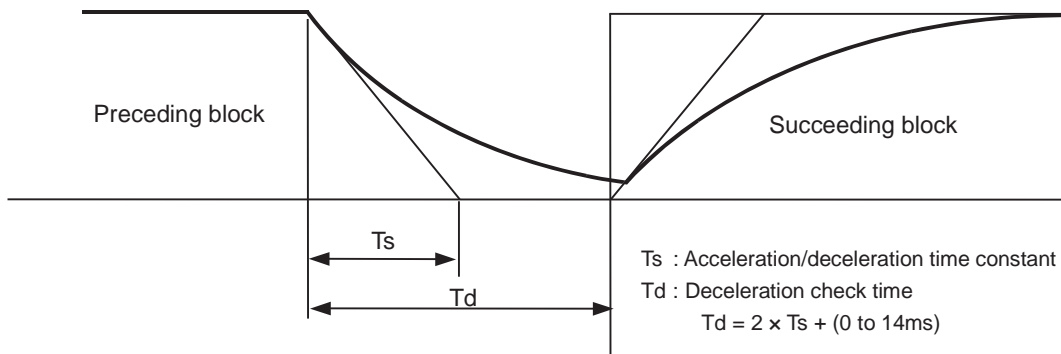

(c) For exponential acceleration and linear deceleration

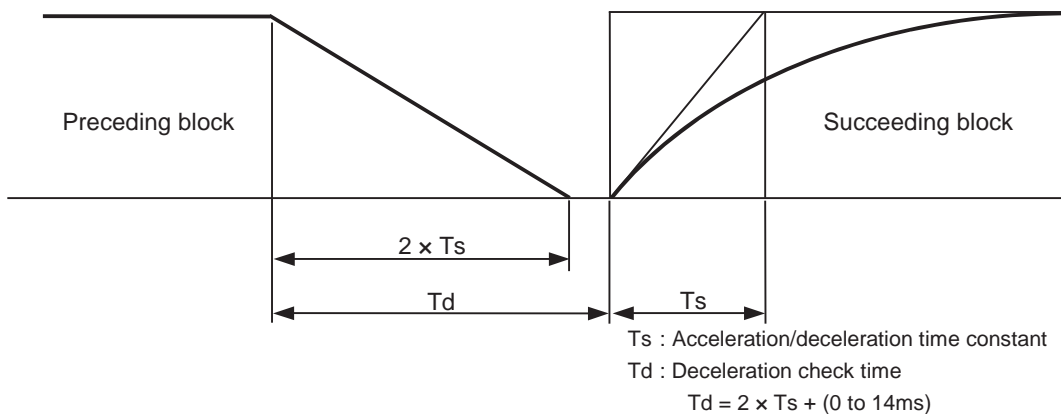

The deceleration check time required during rapid traverse is the longest rapid traverse deceleration check time of all axes. This check time is determined by the rapid traverse acceleration/deceleration mode and rapid traverse acceleration/deceleration time constant of simultaneously commanded axes.

The deceleration check time required during cutting feed is determined in the same manner. It is the longest cutting feed deceleration check time of all axes. This check time is determined by the cutting feed acceleration/deceleration mode and cutting feed acceleration/deceleration time constant of simultaneously commanded axes.

(2) In-position check

When the in-position check is valid, the command deceleration check is carried out. After that, it is confirmed that the servo system positional error is less than the parameter setting value, and the next block is executed.

The in-position check width can be designated with the servo parameter in-position width (SV024).

Note that G0 and G1 can be designated independently with the axis specification parameter G0 in-position check width (G0inps) and G1 in-position check width (G1inps). If both the servo parameter and axis specification parameter are set, the larger value will have the priority.

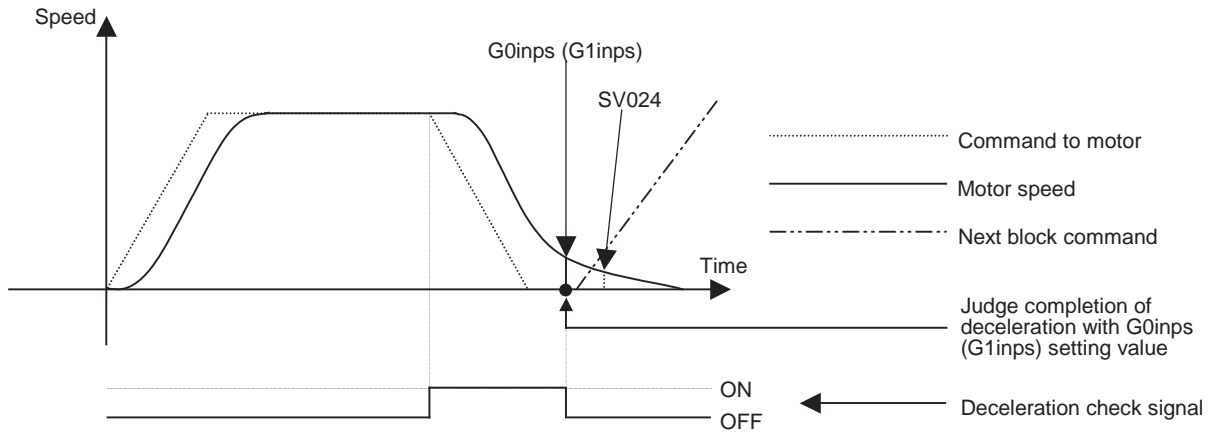

If the SV024 setting value is larger, in-position check will end when the SV024 setting value is established.

6.20.3 Deceleration Check When Opposite Direction Movement Is Reversed

As is mentioned in "(3) Designating deceleration check" in the section "Function", deceleration check cannot be designated for G1 ->G0 or G1 -> G1, but it can be designated in the following manner only when the movement reverses to the opposite direction in successive blocks. Deceleration check can also be executed if even one axis is moving in the opposite direction while several axes are interpolating.

(1) Designating deceleration check for G1 -> G0 opposite direction movement reversal

If the axis movement reverses to the opposite direction in a G1 to G0 successive block, the deceleration check for the movement in the opposite direction can be changed with the base specification parameter G1-> G0 deceleration check (#1502 G0lpfg).

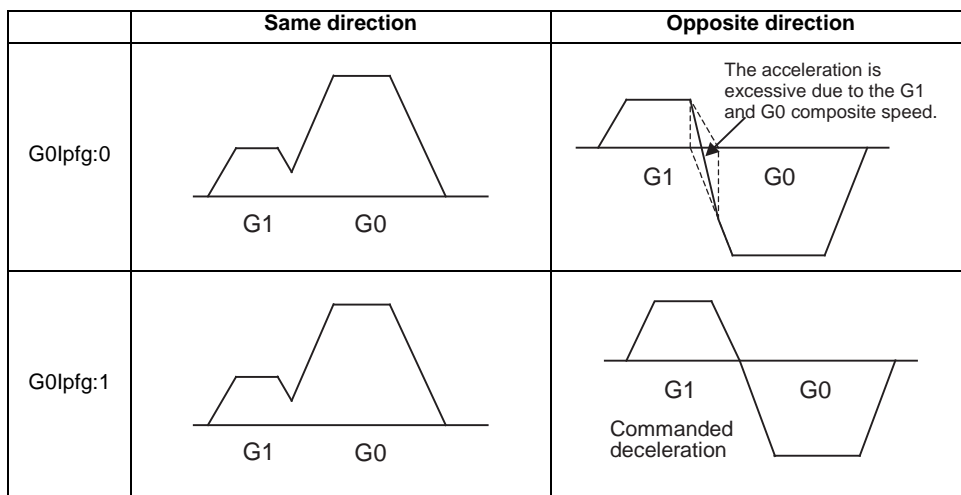

(2) Designating deceleration check for G1 -> G1 opposite direction movement reversal

If the axis movement reverses to the opposite direction in a G1 to G1 successive block, the deceleration check for the movement in the opposite direction can be changed with the base specification parameter G1 -> G1 deceleration check (#1503 G1lpfg).

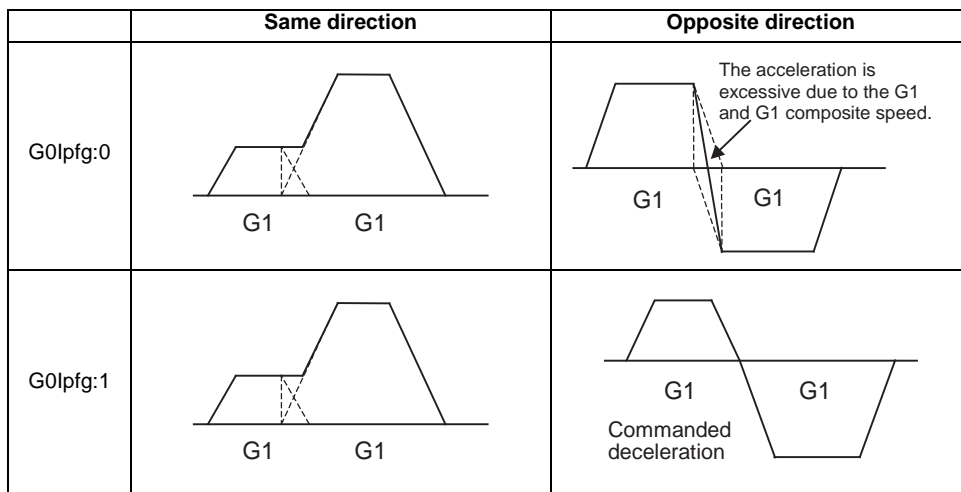

6.20.4 Parameters

- (1) Designation of deceleration check
Base specification parameters

#	Items	Details	Setting range	
1193	inpos	The definitions are changed with the setting of "#1306 InpsTyp Deceleration check specification type".		
		When Deceleration check method 1 is selected	Select the deceleration check method for G0. 0:Command deceleration check 1:In-position check	0 / 1
		When Deceleration check method 2 is selected	Select the deceleration confirmation method for the positioning or cutting command. 0: G0, G1+G9 Command deceleration check 1: G0, G1+G9 In-position check	0 / 1
1223	aux07 /bit1	Deceleration check method 2	Select the deceleration check method in G1+G9. 0:Command deceleration check in G1+G9 1:In-position check in G1+G9 The deceleration check is not performed for the commands except G1+G9. When "#1306 InpsTyp deceleration check specification type" is set to "1" (Deceleration check specification type 2), this parameter will be invalid.	0 / 1
1306	InpsTyp	Deceleration check specification type	Select the parameter specification type for the G0 or G1 deceleration check. 0:Deceleration check specification type 1 G0 is specified with "#1193 inpos", and G1+G9 with "#1223 aux07/bit1". 1:Deceleration check specification type 2 G0 or G1+G9 is specified with "#1193 inpos".	0 / 1

- (2) Deceleration check during opposite direction travel
Base specification parameters

#	Items	Details	Setting range	
1502	G0lpfg	G1 ->G0 deceleration check	Select whether to perform a deceleration check when the travel direction is changed from G1 to G0. 0: Not perform 1: Perform	0 / 1
1503	G1lpfg	G1->G deceleration check	Select whether to perform a deceleration check when the travel direction is changed from G1 to G1. 0: Not perform 1: Perform	0 / 1

(3) Designation of in-position check width

(a) Servo parameter

#	Items		Details	Setting range
2224	SV024 INP	In-position detection width	Set the in-position detection width. Set the accuracy required for the machine. The lower the setting is, the higher the positioning accuracy gets; however, the cycle time (setting time) becomes longer. The standard setting value is "50".	0 - 32767(μ m)

(b) Axis specification parameter

#	Items		Details	Setting range
2077	G0inps	G0 in-position width	Set the in-position width for G0. Between SV024 and this parameter, the parameter with a larger value will be applied. When "0" is set, this parameter will be invalid: only SV024 will be available.	0.000 to 99.999 (mm)
2078	G1inps	G1 in-position width	Set the in-position width for G1. Between SV024 and this parameter, the parameter with a larger value will be applied. When "0" is set, this parameter will be invalid: only SV024 will be available.	0.000 to 99.999 (mm)

6.20.5 Precautions

- (1) Designating deceleration check
 - When in-position check is valid, set the in-position width in the servo parameters.
- (2) Deceleration check for opposite direction movement reversal
 - When deceleration check is valid (G0lpfg=1), deceleration check will be executed when the axis reverses its movement to the opposite direction at the G1 -> G0 successive block regardless of whether G0 non-interpolation is ON or OFF.
 - When deceleration check is valid (G0lpfg=1), deceleration check will be executed when the axis reverses its movement to the opposite direction at the G1 -> G0 successive block even in the fixed cycle.
 - In the G1 -> G28, G1 -> G29 and G1 -> G30 successive blocks, deceleration check will always be executed when the G1 movement is completed, when movement to the intermediate point is completed and when movement to the return point is completed. Note that if the base specification parameter's simple zero point return "#1222 aux06/bit7" is valid, the base specification parameter G1 -> G0 deceleration check (G0lpfg) will be followed when the G1 movement is completed and when movement to the intermediate point is completed. (Deceleration check will always be executed when movement to the return point is completed even in this case.)
- (3) Designating in-position width
 - The in-position width (programmable in-position check width) designated in the machining program has a priority over the in-position width set in the parameters (SV024, G0inps, G1inps).
 - When error detect is ON, in-position check will be forcibly carried out.
- (4) Deceleration check in G1 -> G0/G1 -> G1 opposite direction movement reversal during high-speed machining mode
 - When the axis movement reverses to the opposite direction in a G1 -> G1 successive block during the high-speed machining mode, the commanded deceleration will not take place even if G1lpfg is set to 1. Note that the G0lpfg setting will be followed if the axis direction reverses to the opposite direction in a G1 -> G0 successive block.

- (5) Deceleration check in movement including spindle/C-axis
 - The deceleration check for spindle/C-axis movement command is as described in the table below. That is because a vibration and so on occurs in the machine when the position loop gain (#13002 PGN) is changed during the axis movement.

Parameter	Rapid traverse command	Parameter	Other than rapid traverse command (G1 : other than G0 command)	
Inpos (#1193)	G0 → XX (G0+G9 → XX)	AUX07/BIT-1 (#1223/BIT-1)	G1 → G0 (G1+G9 → XX)	G1 → G1
0	Command deceleration check	0	In-position check (Applicable only to SV024)	No deceleration check
1	In-position check	1		

(Note 1) When G1 command is issued, the in-position check is performed regardless of the deceleration check parameter.

(Note 2) XX expresses all commands.

6.21 External Deceleration

6.21.1 Outline

When the "External deceleration+ n-th axis" (*+EDT1 to *+EDT8), "External deceleration- n-th axis" (*-EDT1 to *-EDT8) signal, an external input from the PLC program, is input, this function immediately drops the feedrate to the external deceleration speed set in the parameters.

6.21.2 Explanation of Function

- (1) The external deceleration signal is provided for each axis and for each movement direction (+/-). The speed will decelerate when a signal in the direction matching the movement direction is input.
- (2) When the axis is returned in the reverse direction, the command speed will be returned to immediately.
- (3) During manual operation or automatic operation's non-interpolation positioning, only the axis for which a signal matching the movement direction is input will decelerate.
- (4) During automatic operation interpolation, if there is any axis for which the input signal matches the movement direction, the feedrate will be lowered to the external deceleration speed.

6.21.3 Combination with Other Functions

- (1) When the following functions are enabled, the external deceleration is disabled.
 - Machine lock axis
 - Synchronous tap modal
 - Tapping mode
 - While moving in the approach speed at automatic reference position return command (G28) or dog-type reference position return during the manual reference position return mode
 - The axis moving with chopping
 - During thread cutting
 - Virtual axis
- (2) If the external deceleration speed is slower than the overridden speed, the speed will drop to the external deceleration speed.
- (3) When calculating the machining time, the external deceleration signal input is not considered.
- (4) When an inch command is issued, the axis moves at the speed obtained by converting the external deceleration speed into inches.
- (5) During the manual speed command, the external deceleration signal is valid for the movement axis as well as the axis and direction that is the same as the selected feed axis (+/-).
- (6) During manual random feed, the external deceleration axis is valid for the same axis and direction as the axis for which manual random feed is valid.
 - (If the manual random feed is valid for the axis but the movement amount is 0, the external deceleration signal + for the same axis will be valid.)
- (7) During manual arc feed, the external deceleration signal for same axis and direction as the selected feed axis (+/-) will be valid instead of the movement axis.

6.21.4 Precautions

- (1) If the external deceleration signal is input while moving at a speed lower than the external deceleration speed, the feedrate will not be affected.
- (2) Excluding during G00 non-interpolation, the composite speed of each axis will be the external deceleration speed during automatic operation.
- (3) The signal is valid after resetting and applying emergency stop.

6.22 Reference Position Retract

6.22.1 Outline

This function returns immediately to a set reference position when the Reference position retract signal is input. This function is used to return to a set position for changing the tool.

6.22.2 Detailed Description

Reference position return is executed when this signal is turned ON. At the rising edge of the signal, the program is automatically reset (reset & rewind) and then reference position return is executed.

During the automatic or MDI operation, the operation is interrupted and stopped by the reset, and reference position return is executed.

If this signal is input during execution of a tap cycle in the automatic or MDI operation modes, the "Tap retract possible" signal will be output by the reset interruption, and the return operation will be the tap retract operation. The tap retract is completed at the initial point, and after that the reference position return will be carried out.

- (1) If there are two or more axes, set the return order with parameter "#2019 revnum".
- (2) When the reference position is reached, the corresponding "Reference position reached" signal will be output.
- (3) This signal must be held until the "Reference position reached" signal is output. If it is turned OFF midway, the return operation will be interrupted and stop. If the signal is input again, the operation will restart from execution of resetting.
- (4) The reference position return speed is handled in the same manner as the normal reference position return speed.
- (5) In this function, an axis returns to the reference position set by the Reference position selection code 1 and 2 signal.
- (6) Even if the return signal is input during the thread cutting cycle, it will be invalid. However, if the return signal is executed in a block other than the thread cutting block, the return operation will be executed.
- (7) The return signal is invalid if the coordinate system is not established. An alarm "M01 Ref point retract invalid" will occur when the return signal is input.

<Timing chart>

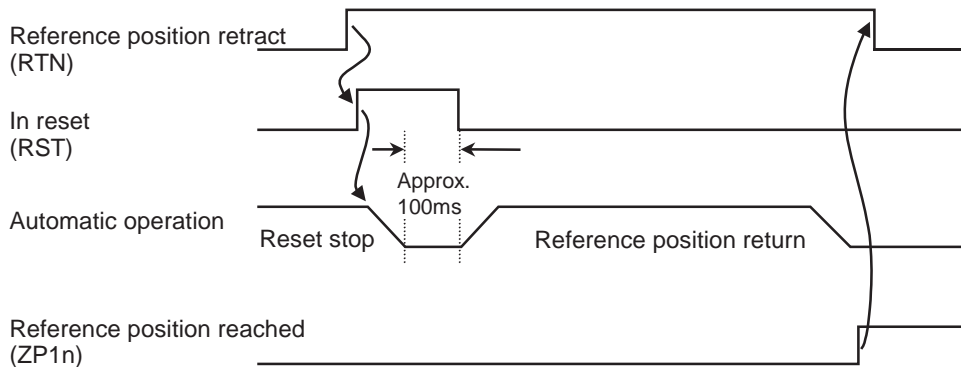

6.23 Spindle Orientation

6.23.1 Outline

(1) Orientation

This function stops the spindle rotation at a certain position when using the digital spindle.

When the orientation command is used, the spindle will rotate several times and then stop at the orientation point.

The orientation position differs depending on the detector.

- When the encoder orientation (PLG and external encoder/ring sensor) is used:

...At the Z-phase position

- When the magnetic sensor (proximity switch) is used:

...At the magnetic sensor installation position

(2) Multi-point orientation

This function performs orientation to a position other than the Z-phase position by inputting a shift amount with the

parameter or PLC. The shift amount is 0 to 35999. (Unit : $\frac{360^\circ}{36000} = 0.01^\circ$)

(Note 1) Multi-point orientation cannot be executed when using the magnetic sensor.

(Note 2) Orientation is possible only when the gear ratio is 1:1 for the PLG orientation.

(The orientation is completed at the PLG encoder's Z-phase, so when using reduction gears, the orientation points will be generated at several points during one spindle rotation.)

(3) Orientation in-position advance output

This function turns the spindle in-position signal ON as soon as the spindle reaches within the second in-position width (parameter "#3132 ori_inp2" (2nd in-position width for orientation)). Then, the spindle 2nd in-position signal is turned ON as soon as the spindle reaches within the in-position width (parameter "#13024 SP024 INP" (In-position width)).

Since orientation completion can be predicted using this function, it is possible to eliminate the sequence delay time, etc. for tool changes and other such operations, thereby achieving a faster tact time.

6.23.2 Orientation Operation

When Z-phase has not yet been passed, pass Z-phase twice (excluding reciprocations within one rotation), and then position to the orientation position.

When Z-phase has been passed already, immediately position to the orientation position.

The spindle does not rotate if Z-phase has been passed and the orientation position is already established when orientation command is issued.

When the spindle has been rotating in the direction opposite from that of orientation rotation when the orientation command is issued, orientation operation will be executed after decelerating to stop.

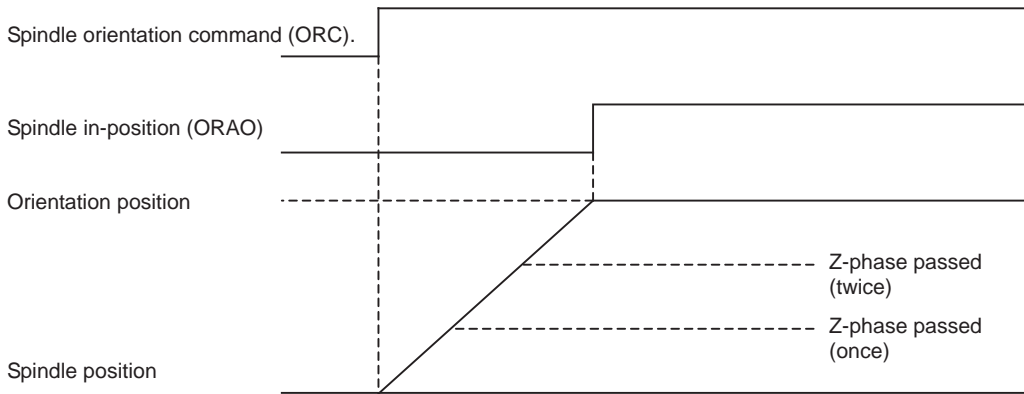

The Acceleration/Deceleration Patterns

(1) The acceleration/deceleration patterns at orientation/position loop reference position return

For the acceleration/deceleration patterns at orientation/position loop reference position return (C axis, tapping), the time constant is set by the parameter "#3115 sp2_t1" to "#3118 sp2_t4" (Time constant in orientation/position loop reference position return). The orientation acceleration/deceleration time is calculated with the following expression.

(Example: The acceleration/deceleration time for gear 00)

$$\text{The acceleration/deceleration time} = \text{sp2_t1} \times \frac{\text{Orientation command speed (\#3107 ori_spd)}}{\text{Limit rotation speed (\#3001 slimt 1)}}$$

For position loop reference position return, the parameter "#3110 tap_spd" (Synchronous tapping zero point return speed) or "#3112 cax_spd" (Spindle C axis zero point return speed) is used for position loop reference position return (C axis, tapping) instead of the orientation command speed.

In any case, when "#3101 sp_t 1" is larger than "#3102 sp_t 2" (Time constant for spindle rotation with S command), "#3101 sp_t 1" is used.

(a) During spindle rotation, and the orientation direction is the same

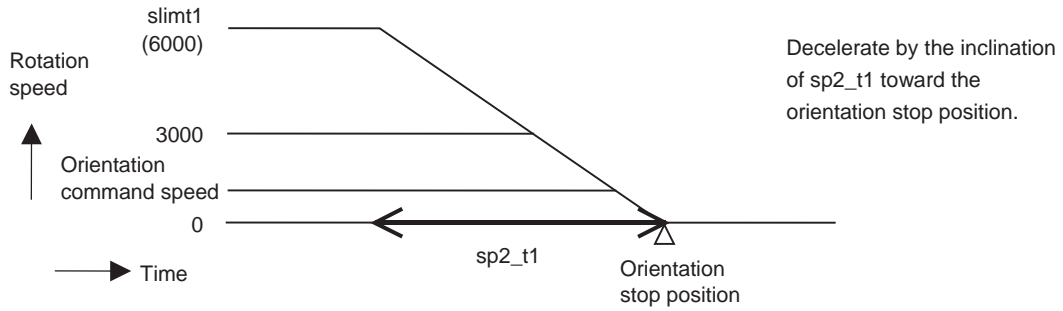

(b) During spindle rotation, and the orientation direction is opposite

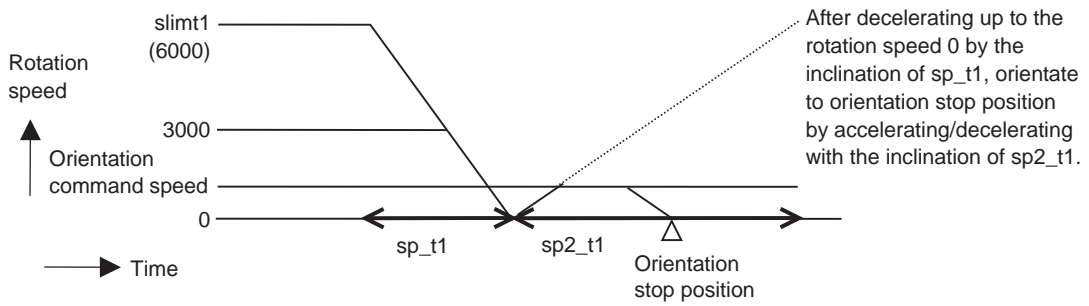

(c) When the spindle is stopping

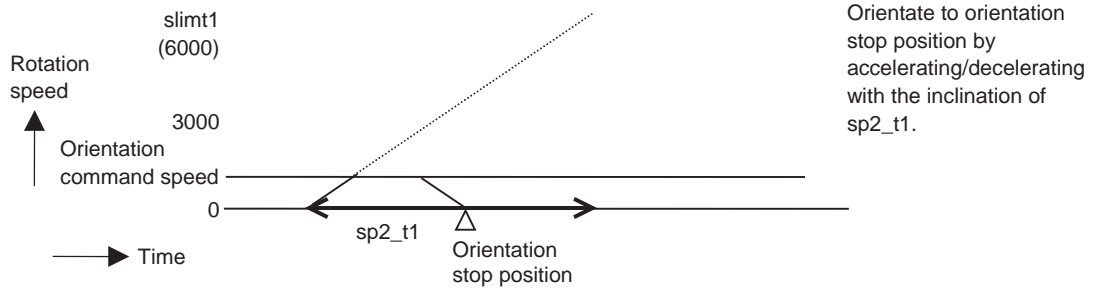

(2) Time constant

The parameter "#3115 sp2_t1" to "#3118 sp2_t4" (Time constant in orientation/position loop reference position return) are used as the time constant of orientation/position loop reference position return. The parameter "#3124 tret_t" (Turret indexing time constant) is used at the turret indexing. Set the relation to the parameters "#3101 sp_t 1" to "#3104 sp_t 4" (Time constant for spindle rotation with S command) as follows.

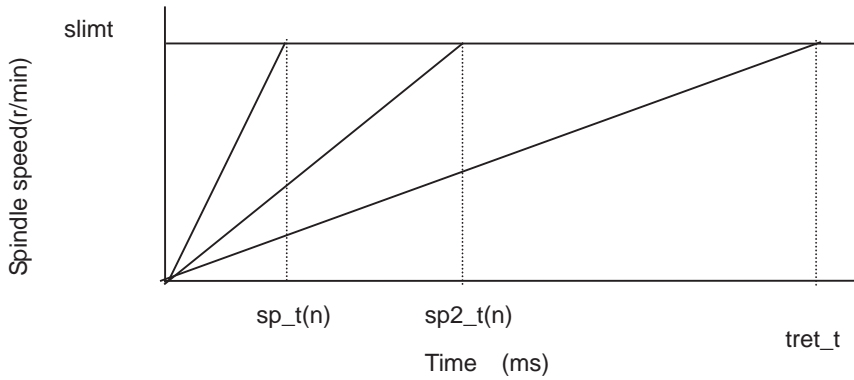

Gain

If the orientation is commanded when the spindle has been stopping, usually the spindle rotates to orientation position using the position loop gain set in the parameter "#13002 SP002(PGN)" (Position loop gain interpolation mode). By setting the parameter "#3106 zrn_typ/bitE" (Interpolation mode selection in orientation), if the orientation is commanded when the spindle has been stopping, the spindle rotates to orientation position using the parameter "#13001 SP001(PGV)" (Position loop gain Non-interpolation mode). When the parameter "#3106 zrn_typ/bitF" (Spindle zero point detection with contactless switch) or the parameter "#3121 tret" (Turret indexing) is set, the parameter "#3106 zrn_typ/bitE" (Interpolation mode selection in orientation) setting is not enabled.



Other Functions

7.1 Stored Stroke Limit

Outline

Tool entry prohibited ranges can be set with stored stroke limit and stored stroke limit II.

As for stored stroke limit, it can be set by selecting entry prohibited ranges on parameter. (II: Prohibits entering outside the range)

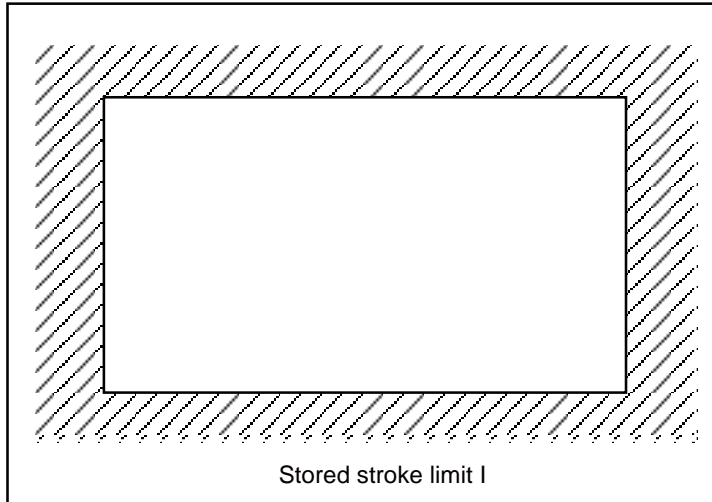

If the tool tries to move over the set range, an alarm will appear, and the axis will decelerate to a stop.

If the prohibited range is entered and an alarm occurs, movement will be possible only in the direction opposite the entry direction.

[Valid Conditions of Stored Stroke Limit]

When using the relative position detection system, the stored stroke limit is invalid until the reference position return is completed after the power is turned ON.

The stored stroke limit can be validated even if the reference position return is not yet completed, by setting parameter #2049 type = 9.

If the absolute position detection is valid when using the absolute position detection system, the stored stroke limit will be validated immediately after the power is turned ON.

[Stored stroke limit coordinates]

The stored stroke limit check is carried out in the basic machine coordinate system established by the reference position return.

To validate the stored stroke limit even when the reference position return is not yet completed, check the stored stroke limit using the temporary basic machine coordinate system (basic coordinate system defined when the power was previously turned OFF).

When the 1st dog-type reference position return is completed after the power is turned OFF, the correct coordinate system is established.

CAUTION

 **Always set the stored stroke limit. Failure to set this could result in collision with the machine end.**

(Note) The axis movement possible when the reference position return has not yet completed is limited to manual and handle feed only. Automatic operation is validated after the reference position return is completed.

Detailed explanation

The stored stroke limit sets a prohibited range with the parameters or program command. The maximum and minimum values of the prohibited range are set as coordinate values (radius values) on the basic machine coordinate system for each axis. If the parameters (#8204 OT-CHECK-N and #8205 OT-CHECK-P), for setting the prohibited range, are set to the same value, the stroke will not be checked. This function is valid only for the axis for which the reference position is established.

If the machine enters the prohibited range, an operation error will occur, and the machine movement will stop. The alarm can be reset by moving the erroneous axis in the opposite direction.

During automatic operation, if an alarm occurs with even one axis, all axes will decelerate to a stop. During manual operation, only the axis that caused the alarm will decelerate to a stop. The axis will always stop at a position before the prohibited range. The distance between the prohibited range and stop position will depend on the feedrate.

The stored stroke limits I, II are handled as follows.

Type	Prohibited range	Explanation	Range setting parameter	Validating conditions
I	Outside	- Set by the machine maker. - When used with II, the narrow range designated by the two types becomes the movement valid range.	#2013 OT- #2014 OT+	- Zero point return is completed. - #2013 and #2014 are not set to the same value.
II	Outside	- Set by the user. - #8210 OT-INSIDE:0 - Used with I.	#8204 OT-CHECK-N #8205 OT-CHECK-P	- Zero point return is completed. - #8204 and #8205 are not set to the same value. - #8202 OT-CHECK OFF: 0

7.1.1 Stored Stroke Limit I

This is a stroke limit function used by the machine tool builder. The boundary is set with the parameters ("#2013 OT - (Soft limit I -)" and "#2014 OT + (Soft limit I +)"). The outside of the set boundary is the prohibited range. The outside of the set boundary is the prohibited range.

When used with the stored stroke limit II function, the confined range designated by the two functions becomes the moveable range.

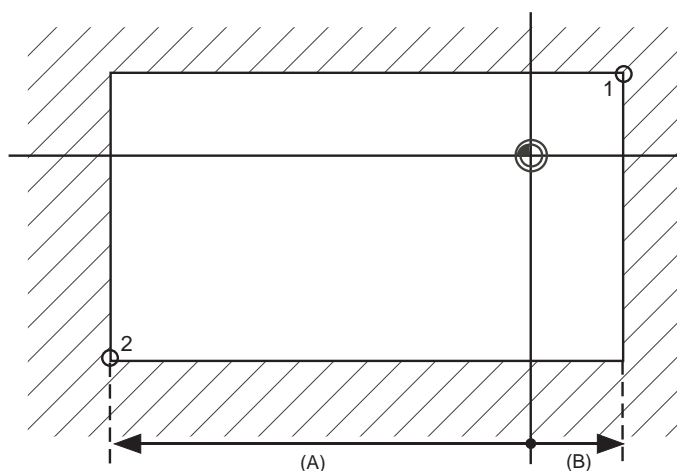

 : Moveable range

 : Prohibited range

(A): Set value for (-) side

(B): Set value for (+) side

Point 1: "#2014 OT+ (Soft limit I +)" and

Point 2: "#2013 OT- (Soft limit I -)" are set with the coordinate values in the basic machine coordinate system.

(Note) This function will be invalid if the same value excluding "0" is set for both "#2013 OT -" and "#2014 OT +".

7.1.2 Stored Stroke Limit II

The boundary is set with the axis parameters "#8204 OT-CHECK-N" and "#8205 OT-CHECK-P" or with program commands. The outside of the set boundary is the prohibited range.

When using program commands, entry of the tool into the prohibited range is prohibited with G22, and entry into the prohibited range is enabled with G23. The stored stroke limit II can be invalidated for each axis with setting "#8202 OT-CHECK OFF" to "1".

Prohibited range

X: Outside Z: Outside

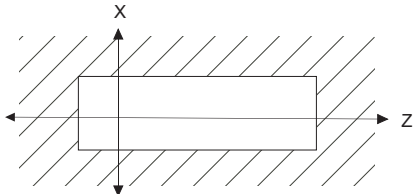

- : Moveable range
- : Prohibited range

(1) Stored stroke limit II (When prohibited range is on outside)

When used with the stored stroke limit I function, the narrow range designated by the two types becomes the movement valid range.

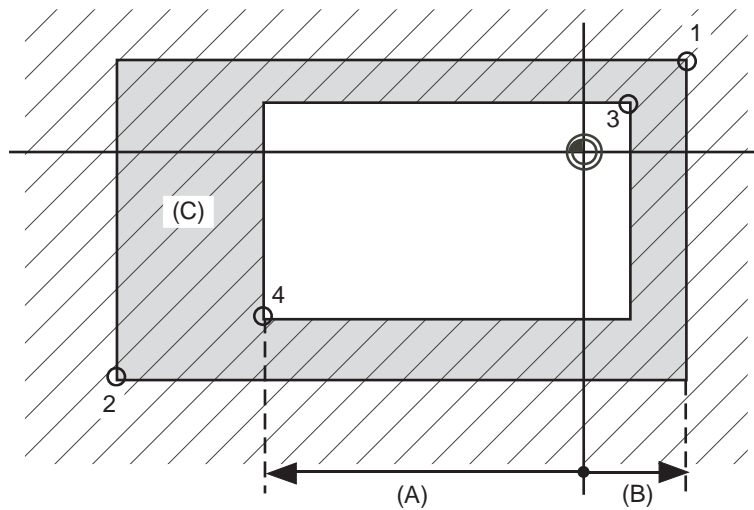

- : Moveable range
- : Prohibited range

(A): Set value for (-) side

(B): Set value for (+) side

(C): Prohibited range by stored stroke limit II

Point 3: "#8205 OT-CHECK-P" and

Point 4: "#8204 OT-CHECK-N" are set with the coordinate values in the basic machine coordinate system.

Points 1 and 2 are the prohibited range set with stored stroke limit I.

7.1.3 Stored Stroke Limit for Rotation Axis

Stored stroke limits I and II are used as the stored stroke limit for the rotation axis. The area between the maximum and minimum values of the prohibited range's parameters, which does not contain the 0 point of the basic machine coordinate system, is the entry prohibited range.

The prohibited range parameters for the rotation axis can be set to establish "maximum value < minimum value" ("#2014 OT+" < "#2013 OT-", "#8205 OT-CHECK-P" < "#8204 OT-CHECK-N").

This will be handled in the same manner as if "maximum value > minimum value" ("#2014 OT+" > "#2013 OT-", "#8205 OT-CHECK-P" > "#8204 OT-CHECK-N").

(Example)

Stored stroke limit I (maximum value and minimum value of prohibited range parameter)

#2013 OT-: -70.000°

#2014 OT+: 60.000°

Stored stroke limit II (maximum value and minimum value of prohibited range parameter)

#8204 Soft limit - : 30.000°

#8205 Soft limit + : 80.000°

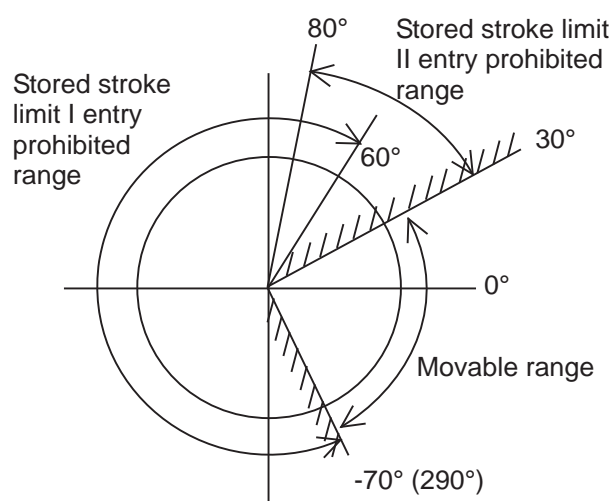

7.1.4 Changing the Area for the Stored Stroke Limit I

The range of the stored stroke limit I can be changed to the value set to R register for each axis. When "Stored stroke limit I change request" signal is turned ON, the range of stored stroke limit changes. Changing the area for the stored stroke limit I is also possible during automatic operation. Also, the current settings for the stored stroke limit I can be checked by with the R register values.

Refer to "PLC Programming Manual" and "PLC Interface Manual" for details.

7.1.5 Precautions

- (1) If the maximum value and minimum value of the stored stroke limit's prohibited range are set to the same value, the following will occur.
 - When the maximum value and minimum value are set to 0, if the outside is the prohibited range, the entire range will be prohibited. If the inside is the prohibited range, the entire range will be the moveable range.
 - If data other than 0 is set for the maximum value and minimum value, the entire range will be the moveable range.
- (2) To make inside the prohibited range, set the parameters as follows:

(Ex.) There are two setting methods to make 10° to 70° the prohibited range.

(Method 1) #2013 OT- : 70° #2014 OT+ : 370°

(Method 2) #2013 OT- : 370° #2014 OT+ : 70°

7.2 Chuck Barrier/Tailstock Barrier (L System)

By limiting the tool nose movement range, the chuck barrier and tailstock barrier prevent collision with the chuck and tailstock due to programming errors. If movement is commanded which exceeds the region set in the parameters, the tool will automatically stop at the barrier boundary.

This function can be set by G code or PLC signal.

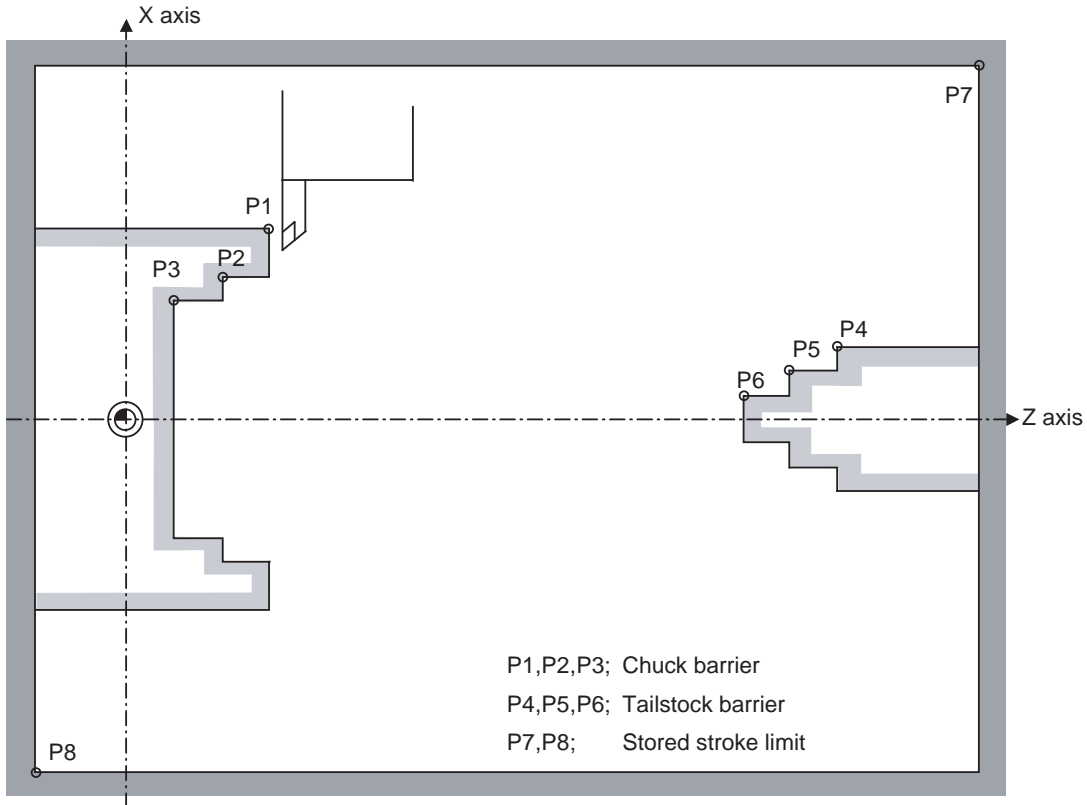

7.2.1 Detailed Description

- (1) An alarm will appear if the machine stops because it was about to exceed the set region.
Reset to cancel this alarm.
- (2) This function is also valid during machine lock.
- (3) This function is validated when all axes in which chuck barrier and tailstock barrier are set have finished their reference position returns.
- (4) When there is a stored stroke check function, and the stored stroke limit region is set, the chuck barrier/tailstock barrier function is validated simultaneously with the stored stroke check function.

7.2.2 Setting the Chuck Barrier/Tailstock Barrier

(1) Using G22 and G23

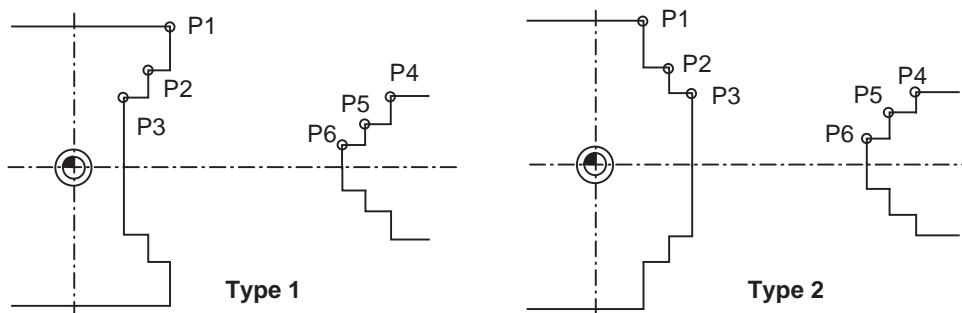

- (a) Three points can be input as parameters for both the chuck barrier and tailstock barrier. Set in the machine coordinate system.
Points P1, P2 and P3 (parameter "#8301 P1" to "#8303 P3") are for the chuck barrier. Points P4, P5 and P6 (parameter "#8304 P4" to "#8306 P6") are for the tailstock barrier.
- (b) The barrier region should be a symmetric shape regarding the Z axis. When the X axis coordinates of barrier point P_ are a negative value, reverse the sign to the positive side, then convert and check.
The absolute value of each barrier point's X axis coordinates must be set as follows.

$$P1 \geq P2 \geq P3$$

$$P4 \geq P5 \geq P6$$

(Note that the Z axis coordinates do not have to follow this setting.)

(2) Using the PLC external signal input

Set the coordinate values for each point between "#8300 P0" to "#8314 P10".

P0 is the basic X coordinate of the chuck and tailstock barrier. Set the workpiece center coordinate in the basic machine coordinate system as a radius value.

The coordinate value from the workpiece center (P0) is set as a radius value for the P1 to P10 X axes. The Z axis is set as a basic machine coordinate system coordinate.

The barrier region is symmetrical in respect to P0.

The X axis coordinate of each point must be set in the following manner.

$$P1 \geq P2 \geq P3$$

$$P4 \geq P5 \geq P6$$

$$P7 \geq P8$$

$$P9 \geq P10$$

If the P8 Z axis coordinate must be less than P1 to P3, and the P10 Z axis coordinate must be more than P4 to P6.

The positions of the P0 to P10 points in the chuck/tailstock are as follow.

(a) Setting the chuck

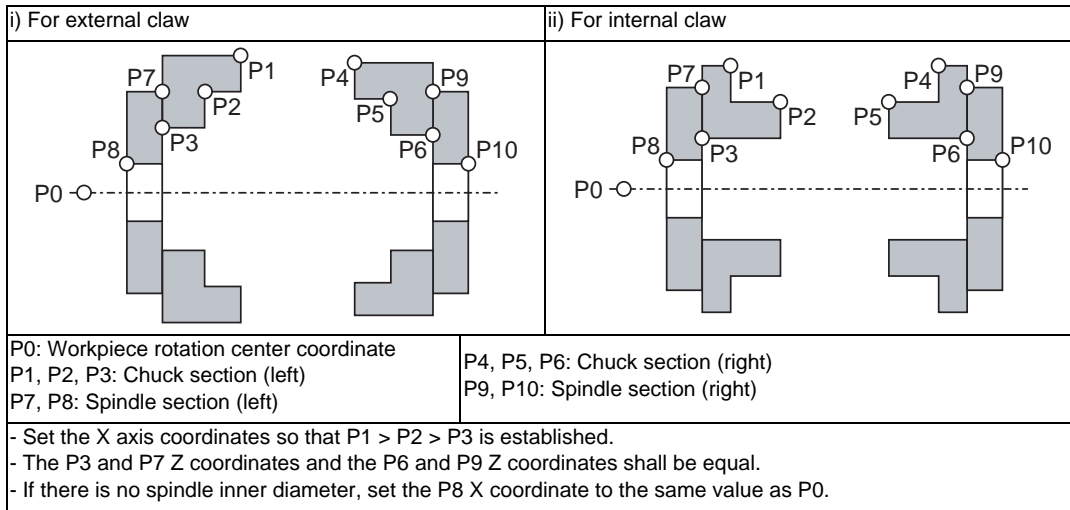

If a spindle section is not to be set, set the P3, P7 and P8 values to the same values, and the P6, P9 and P10 values to the same values. The barrier range will be as shown below in this case.

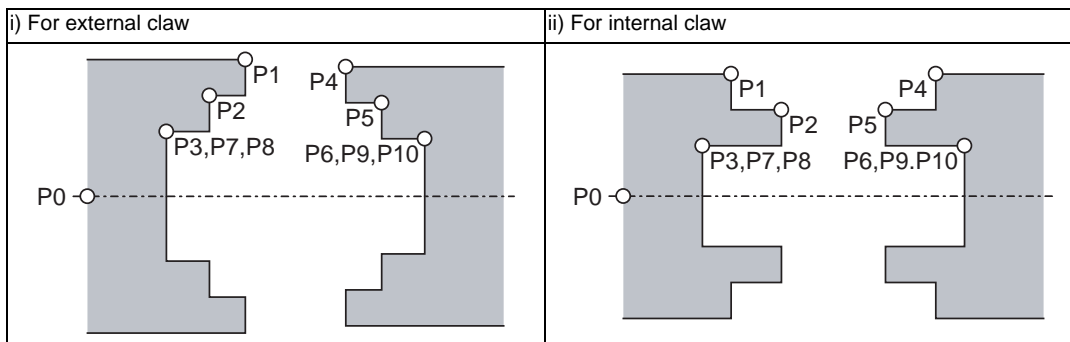

(b) Setting the tailstock

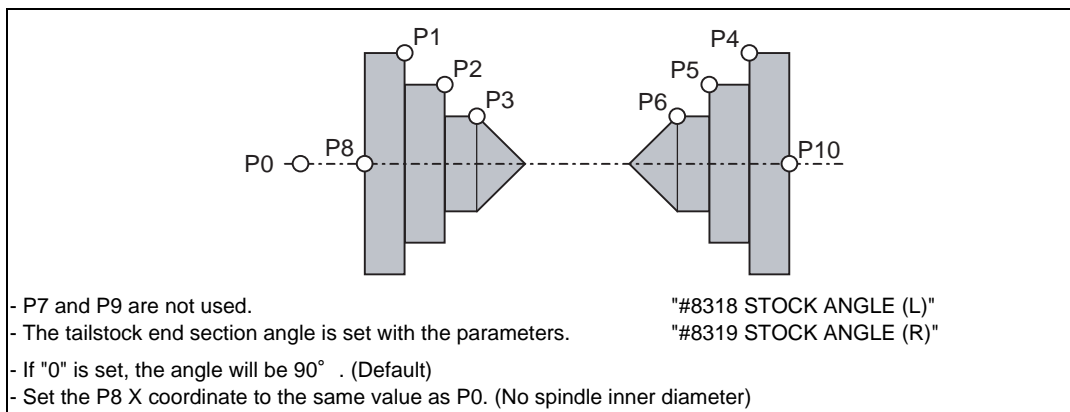

7.2.3 Restrictions

- (1) There is only one checkpoint from the tool regarding the chuck barrier/tailstock barrier. Therefore, the following cautions must be observed.

In the following examples, when the barrier points are set to be checked by the hypothetical tool nose point and the tool moves in the direction of the arrow in the drawing, the following situation may occur.

In Example 1, there is a checkpoint in the range "a", so the tool will automatically stop at the barrier boundary. However, in Example 2 there is a checkpoint in range "b", so the chuck and tool may collide in range "a".

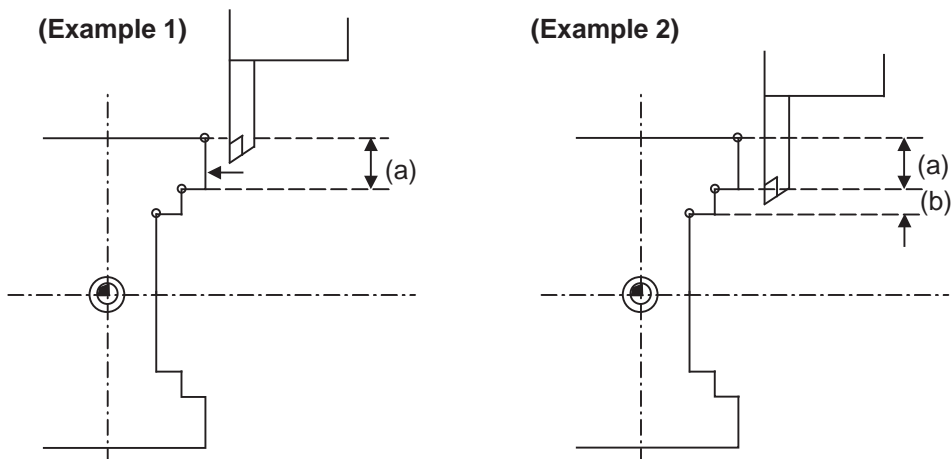

To avoid this, Example 3 is given. In this example, if the barrier points P1, P2 and P3 are set and the checkpoint is set in range "c", the tool can be stopped at the barrier boundary.

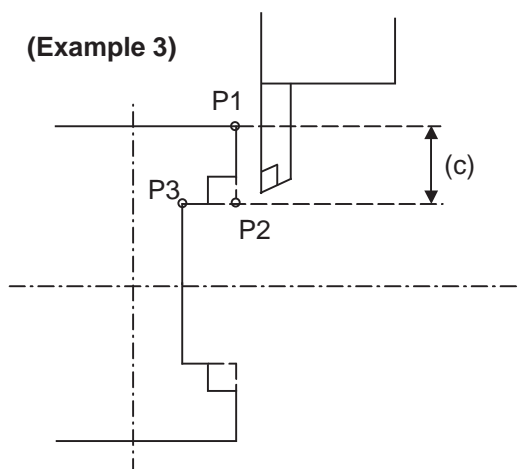

- (2) When the tool enters the barrier region and an alarm occurs, the tool may move in the opposite direction from which it came, once the alarm is canceled by resetting.
- (3) There is no barrier region for axes without a reference position return function. Thus, there is no barrier alarm for that axis.
- (4) When the tool enters a canceled barrier region, and that barrier is then validated, an alarm will result immediately if the tool is moved.
If the alarm is canceled with reset in this manner, invalidate the barrier (G23) before escaping or change the value set for each barrier point.
- (5) The soft limit is valid even if the barrier is invalid (G23)

7.3 Manual Synchronous Tapping

7.3.1 Outline

After a synchronous tap cycle is stopped with block stop or feed hold stop, this function carries out tapping by selecting and moving the drilling axis with manual handle operation.

7.3.2 Command Format

This function is commanded with the same format as for synchronous tapping.

7.3.3 Operation Procedures

The procedures for manual synchronous tapping are described below.

- (1) When using the multiple spindle specifications, select the command spindle.
- (2) Stop the spindle and servo axis, and select the automatic operation mode.
- (3) Execute the synchronous tapping cycle program.
- (4) Apply block stop or feed hold stop.
- (5) Change to the handle mode. Select and move the drilling axis.
- (6) To cancel manual synchronous tapping, execute G80 in the same manner as the normal synchronous tap mode, or reset the program.

7.3.4 Precautions

- (1) When selecting the axis for the handle mode, select the same axis as that commanded in the program.
- (2) After executing the program with automatic operation, do not reset the program until manual synchronous tapping is completed.

The manual synchronous tapping mode will be canceled even if reset is applied in the handle mode.

- (3) During manual synchronous tapping, the acceleration/deceleration time constant is the same as normal handle operation. The return override is also invalid.
- (4) When using the multiple spindle specifications, changes to the commanded spindle selection will be validated after G80; is executed or reset is input to cancel synchronous tapping, and then manual synchronous tapping is started.
- (5) The spindle rotation speed during manual synchronous tapping is not clamped by the program's S command or parameter "#3013 stap1" to "#3016 stap4" (tap rotation speed).
- (6) Manual synchronous tapping is valid from the point that synchronous tapping and cutting is carried out once during automatic operation, and block stop is applied.

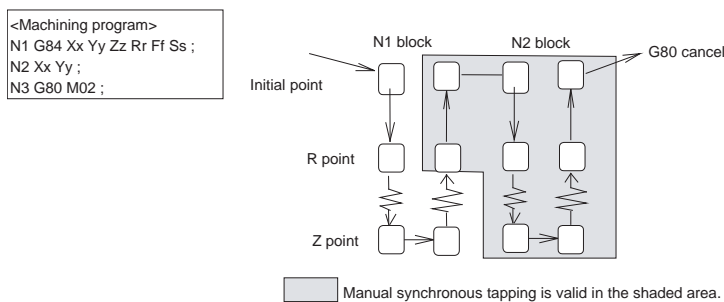

(Note) To validate manual synchronous tapping without carrying out cutting, run the following type of program with no movement commands.

```
G91 G84 X0 Y0 Z0 R0 F2. S1000 ;
```

7.4 System Lock

System lock is a function with which a machine tool builder can impose a time limit on CNC. Once the expiry date is passed, the user will be unable to activate a cycle start. If the user enters the decryption code issued by the machine tool builder, he or she can set a new time limit or cancel the time limit.

7.4.1 Detailed Description

Display of Time Limit

To check the time limit, open the [Diagn] screen and press [Self diagn]. Then the set expiry date appears as illustrated in the following figure.

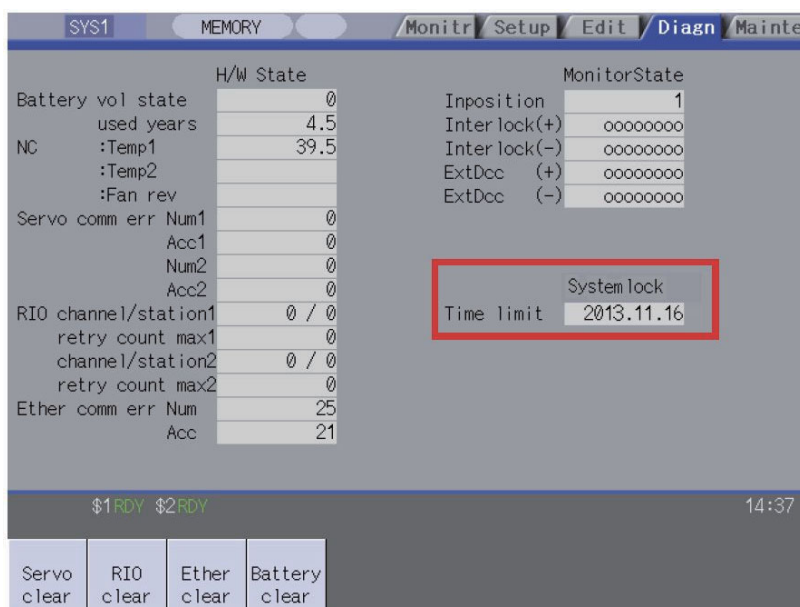

Display of Time Limit Warning and Alarm

If the number of days remaining before expiration reaches 7 or less, the warning "Z64 Valid term soon to be expired" appears at the bottom right of the screen. This warning appears at every cycle start after power ON until the expiry date comes, but can be cancelled by Reset. Cycle start operation is enabled before the expiry date.

If the expiry date is passed, the alarm message "Z65 Valid term has been expired" appears, which disables cycle start operation. Reset signal is unable to cancel this alarm. Instead, enter the decryption code issued by a machine tool builder, and then turn OFF and ON the NC power.

If the expiry date is over during a cycle start operation, the operation will continue until Reset is input.

Refer to "1.3 Screen Configuration" in "I SCREEN OPERATIONS" for the display position of warning and alarm messages.

While the warning is occurring, you can check the number of days remaining before the expiry date. Open [Diagn] - [Alarm message] - [NC message] screen, then you can check the number of days as illustrated in the following figure. The number of remaining days reaches 0 on the expiry date.

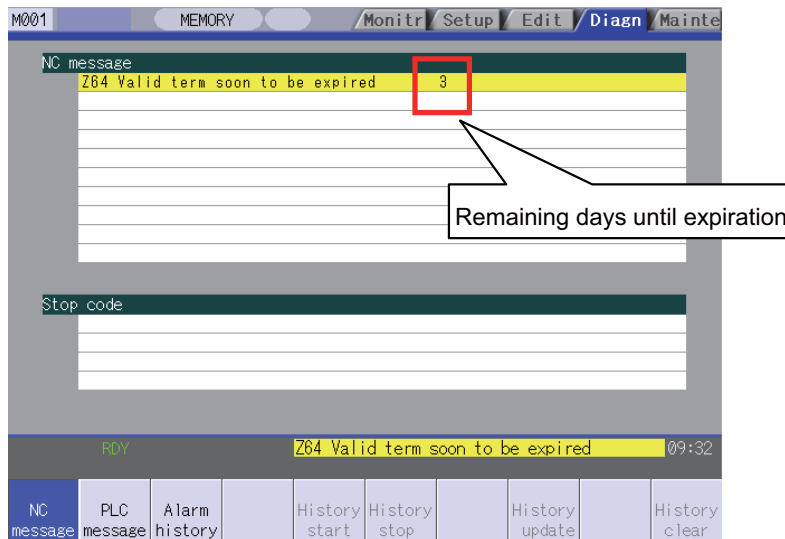

If you open this screen while the alarm is occurring, the screen as in the following figure appears. If you attempt a cycle start operation, the stop code "T01 Cycle st. prohibit (Term exp'd)" results, which disables cycle start operation.

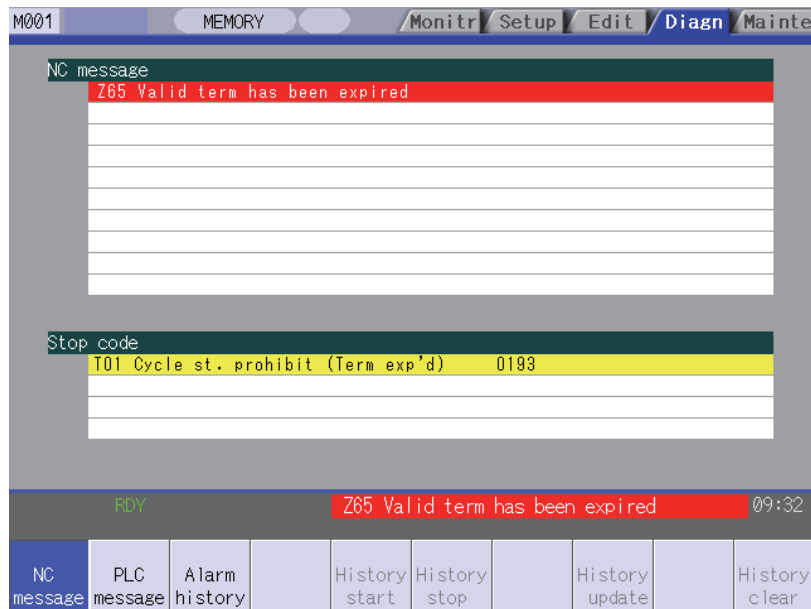

Renewing Time Limit

For updating the time limit, the end user needs to ask the machine tool builder to issue a decryption code. The time limit is either updated or cancelled when the decryption code is entered.

A decryption code is provided by a machine builder in one of the following two forms.

- Decryption code in the form of file
- Decryption code in the form of character string

(1) Procedures when decryption code is provided in the form of character string

Follow the steps below to create a decryption code file through a personal computer. You can skip these procedures if a decryption code is provided in the form of file.

<How to create the file through a PC>

- (a) Open a text editor.
- (b) Type the decryption code in ASCII (Upper case only) in one line.
- (c) Save the text file under an arbitrary name (made up of alphanumeric) with an arbitrary extension.

(2) How to enter decryption code

- (a) Save the decryption code file on a compact flash (or USB) memory.
- (b) Insert the compact flash card into the control unit.
- (c) Open the [Mainte] screen and select [Input/Output].
- (d) In the [A:Dev] field, specify a memory card (or USB memory) in [Dev], a directory where the decryption code is stored in [Dir], and the created decryption code file name in [File].
- (e) Select "Memory" in [B:Dev] and press [Dir]. Then the menu key [Decrypt code] appears on the screen. When [Decrypt code] is pressed, "Decryption Code" automatically appears in [Dir] and "PASSCODE.DAT" in [File]. If you enter "/RLS" in [Dir], the screen will be displayed in the same way.
- (f) Press [Trnsfr A->B].
- (g) When a confirmation message appears, press either [Y] or [INPUT].
If the decryption code has successfully been set, "Setting complete normally" appears.
 - If the warning message is on the screen, this message will be removed.
 - If the alarm message is on the screen, this message will be removed.
 - If the decryption code is wrong, the message "Can't write file for dev B" will appear. Check the decryption code file and contact the machine tool builder.
 - The "Executing automatic operation" error occurs during program operation, and setting the code is disabled.
- (h) Turn OFF and ON the NC power.

7.4.2 Caution

If you turn OFF and ON the power after the time limit has expired, "EMG Emergency stop LINE" may appear at the same time.

III MAINTENANCE



Daily Maintenance and Periodic Inspection and Maintenance

1.1 Maintenance Items

Maintenance is categorized into daily maintenance items (items to be carried at set intervals) and periodic maintenance items (replacement of parts when life is reached).

Some parts will not function in a hardware manner when the life is reached, so these should be replaced before the life is reached.

Class	Name	Life	Inspection/replacement	Remarks
Daily maintenance	Escutcheon		Once/two months (Accordingly when dirty)	
Periodic maintenance	Battery (lithium battery)	Cumulative data holding time:45,000 hr	When battery voltage drop caution alarm occurs (Guideline: approx. 5 years)	Refer to section "Hardware Replacement Methods" for details.
	Back light	50,000 hr	Refer to left.	
Other consumable parts	Operation board	10 ⁶ punches	Refer to left.	

1.1.1 Escutcheon

- (1) Cleaning the escutcheon
 - (a) Prepare the rear side of the escutcheon to clean.
 - (b) Wipe the escutcheon with a soft, clean, dry cloth. If cleaning is still required, put some neutral detergent on a cloth and wipe. Do not use alcohol, thinner, etc.

1.1.2 LCD Panel

- (1) Handling the LCD panel
 - (a) Precautions for use
 - The polarizing plate (display surface) of the LCD panel surface can be easily scratched, so be careful during handling.
 - Glass is used in the LCD panel. Be careful not to drop the LCD panel or allow it to hit hard objects, as the glass may chip or break.
 - The polarizing plate may be stained or discolored if drops of water, etc., adhere to it for long periods, so be sure to wipe off any moisture immediately.
 - Wipe off any dirt, dust, etc., on the polarizing plate using absorbent cotton or other soft cloth.
 - A CMOS LSI is used in the LCD panel, so be careful of static electricity when handling.
 - Never disassemble the LCD panel. Doing so will damage the panel.
 - (b) Precautions for storage
 - Do not store the LCD panel in locations having a high temperature or humidity. (Store within the storage temperature range.)
 - When storing the LCD panel as an individual unit, be sure that other objects do not touch or hit the polarizing plate (display surface).
 - When storing the LCD panel for long periods, be sure to store in a dark place away from exposure to direct sunlight or fluorescent light.

- (2) Other precautions for use
 - (a) Backlight life

The life of the backlight is 50,000hours. (ambient temperature 25C°)
These are the time for luminance to drop to 50% of the initial value.
The backlight life is dependent on the temperature. The life tends to be shorter when used continuously at lower temperatures.
 - (b) Luminance start

Due to the characteristics of the backlight, the luminance could drop slightly at lower temperatures. It will take approx.10 to 15 minutes for the luminance to reach the rated value after the power is turned ON.
 - (c) Unevenness, luminescent spots and irregularities

Uneven brightness, small luminescent spots or small dark spots may appear on LCD panel, but this is not a fault.

- (3) Replacing the backlight

Replacement should be commissioned to the Mitsubishi Service Center.

1.1.3 Compact Flash/USB memory

- (1) Handling the compact flash/USB memory

The general handling methods for the compact flash/USB memory are described below.
Refer to the instruction manual of the compact flash/USB memory used for details.

 - (a) Precautions for use
 - Insert the card in the correct direction.
 - Do not touch the connector area with hands or metal.
 - Do not apply excessive force to the connector area.
 - Do not subject the card to bending or strong impacts.
 - Do not open the cover or disassemble the card.
 - Do not use the card in dusty locations.

 - (b) Precautions for storage
 - Do not store the card in locations having a high temperature or humidity.
 - Do not store the card in dusty locations.

Hardware Replacement Methods

2.1 Durable Parts

[List of durable parts]

Durable parts	Part type
Control unit battery	Q6BAT
Backlight for FCU7-DU120-13 (*)	84LHS16
Key sheet for FCU7-KB024/44	N330B532G51
Key sheet for FCU7-KB025	N330B532G52

(*) Contact the Service Center, Service Station, Sales Office or delayer for repairs or part replacement.

[List of replacements]

Replacements	Part type
Protection fuse	LM40

2.1.1 Control Unit Battery

A lithium battery in the control unit battery holder retains parameter settings, machining programs and the like, which requires to be backed up at the power OFF.

Battery	Q6BAT
Battery cumulative data holding time	45,000 hours (At 0 to 45° C. The life will be shorter if the temperature is high.)
Battery life	Approx. 5 years (from date of battery manufacture)

(Note) Replace the battery within one month after the alarm "Z52 Battery drop 0001" appears on the NC screen. The internal data may have been damaged if the alarm "Z52 Battery drop 0003" appears.

[Replacement procedures]

Always replace the battery with the control unit (machine) power turned OFF.

Complete the replacement within 30 minutes after turning the power OFF. (If the battery is not connected within 30 minutes, the data being backed up might be destroyed.)

- (1) Check that the machine power is turned OFF. (If the power is not OFF, turn it OFF.)
- (2) Confirm that the control unit LED, 7-segment display, etc., are all OFF.
- (3) Open the battery cover of the control unit. Pull the right side of the battery cover toward front.
- (4) Disconnect the battery connector from the control unit BAT connector.
- (5) Remove the battery from the battery holder.
- (6) Fit the new battery into the battery holder.
- (7) Insert the new battery connector into the control unit BAT connector. Pay attention to the connector orientation: do not insert backwards.
- (8) Close the front cover of the control unit. At this time, confirm that the cover is closed by listening for the "click" sound when the latch catches.
- (9) Turn the power ON and check the integrated time screen. Should the displayed current time and/or date be inaccurate, correct them and turn the power OFF and ON.
- (10) Select [Battery clear] on the self diagn screen, and set "0" to battery used years.

(Note) If battery used years is not cleared, passed years from default date (2006/4/1) will be displayed on battery used years.

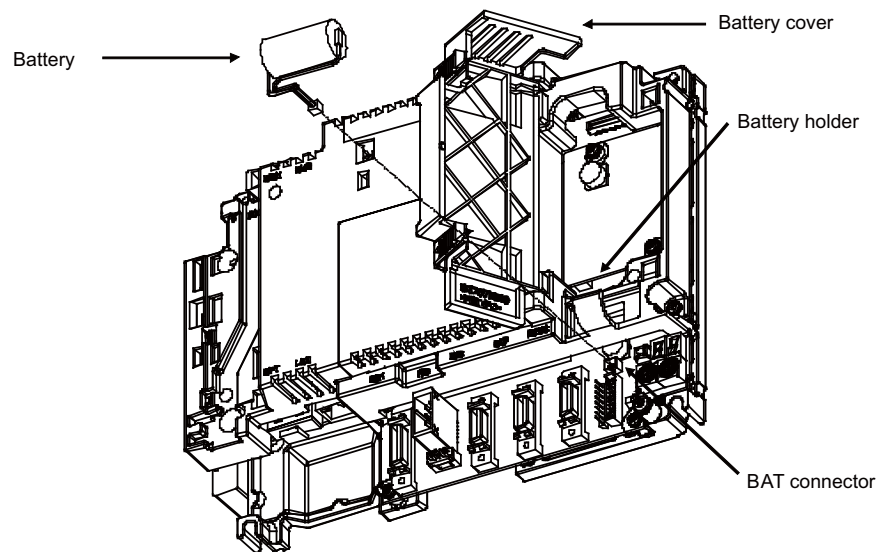
**[Precautions for handling battery]**

- (1) Always replace the battery with the same type.
- (2) Do not disassemble the battery.
- (3) Do not place the battery in flames or water.
- (4) Do not pressurize and deform the battery.
- (5) This is a primary battery so do not charge it.
- (6) Dispose the spent battery as industrial waste in accordance with the local law.

⚠ WARNING

If the battery low warning is issued, save the machining programs, tool data and parameters in an input/output device, and then replace the battery. When the battery alarm is issued, the machining programs, tool data and parameters may have been destroyed. Replace the battery and then reload the data.

⚠ CAUTION

1. Do not short-circuit, charge, overheat, incinerate or disassemble the battery.
2. Dispose the spent battery according to the local laws.

2.1.2 Backlight

- 8.4-type

Driver: HN281

Backlight for replacement : 84LHS16

Backlight life : 70,000 hours (Duration of time until luminance drops to 50% of the initial value.)

The life is estimated on the assumption that it is used under 25 °C environment. Keep in mind that the value above is not a guaranteed value.

[Replacement procedures]

Always replace the backlight for LCD panel with the control unit (machine) power turned OFF.

- (1) Check that the machine power is turned OFF. (If the power is not OFF, turn it OFF.)
- (2) Disconnect the backlight connector from the backlight driver (one for top).
- (3) Disconnect the MENU connector.
- (4) Remove the escutcheon fixing screws (at 4 places) and take the escutcheon off.
- (5) Remove the 4 fixing screws that are holding the LCD panel, and remove the LCD panel. Unplug the LCD cable from the LCD panel at this time.
- (6) Unplug the LED backlight cable.
- (7) Pull out the backlight installed on the left side of the LCD panel. (The backlights have locking claws on the front. Hold these claws down while pulling the backlight out.)
- (8) Insert the new backlight into the upper and lower sections at the left end of the LCD panel. (Press in until the locking claws click.)
- (9) Connect the LED backlight cable to the new backlight.
- (10) Connect the LCD cable to the LCD panel, and mount the LCD panel using the 4 fixing screws.
- (11) Mount the escutcheon with 4 fixing screws (one each for 4 sections).
- (12) Connect the backlight connector to the backlight driver.
- (13) Confirm that all the cables are correctly connected and close the electric cabinet door.
- (14) Connect the MENU connector.

[Precautions for using LCD panel]

- (1) Response time, brightness and color may differ depending on the ambient temperature.
- (2) Brightness nonuniformity, flickers and streaks may be observed on LCD display depending on the display contents.
- (3) Because cold cathode-tube is used for LCD display, optical characteristics (brightness nonuniformity and display) change according to the operation time. (Especially in low temperature.)
- (4) Screen display color may differ depending on the angle to view it.

CAUTION

1. Do not replace the backlight while the power is ON.
2. Dispose the spent backlight according to the local laws.
3. Do not touch the backlight while the power is ON. Failure to observe this could result in electric shocks due to high voltage.
4. Do not touch the backlight while the LCD panel is in use. Failure to observe this could result in burns.
5. Do not apply impact or pressure on the LCD panel or backlight. Failure to observe this could result in breakage as they are made of glass.

[8.4-type display unit]

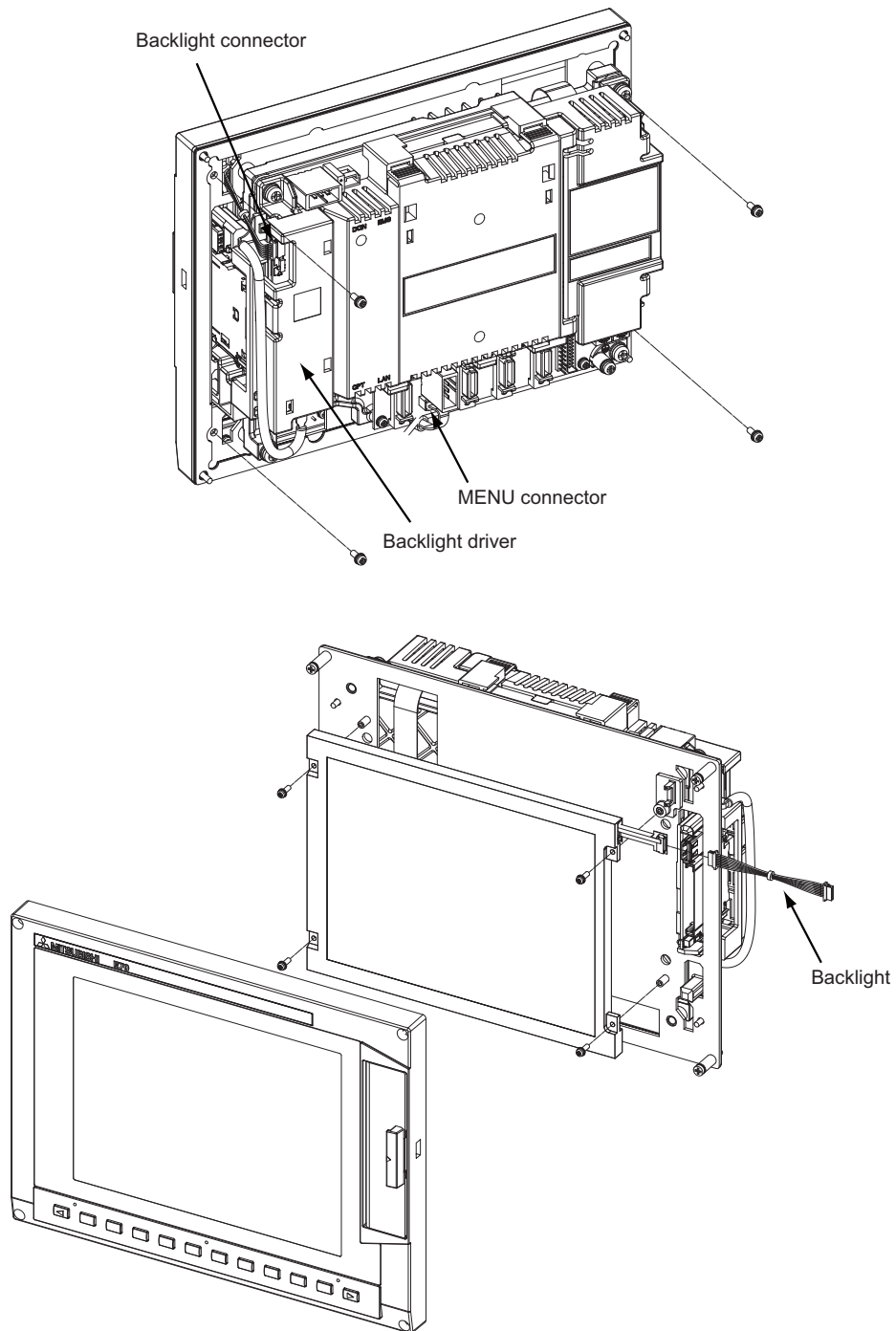

2.1.3 Fuse

2.1.3.1 Control Unit Protection Fuse

Disconnection of the protection fuse will be caused by misconnections such as a reverse connection of 24VDC power supply connector between +24V terminal and the ground.

Hold the upper part of the protection fuse and pull it when replacing it.

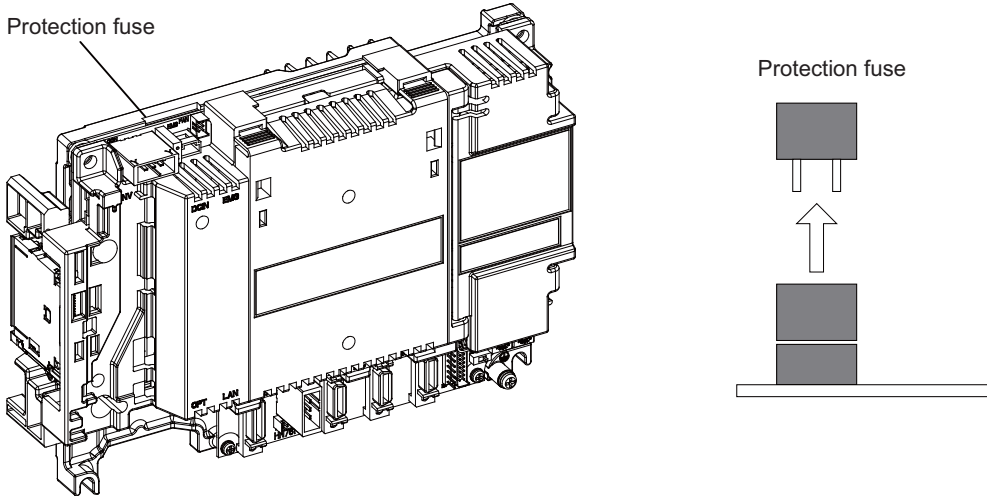

Replacements	Part type
Protection fuse	LM40

2.1.3.2 Operation Panel I/O Unit Protection Fuse

Disconnection of the protection fuse will be caused by misconnections of digital inputs/outputs.

Hold the upper part of the protection fuse and pull it when replacing it.

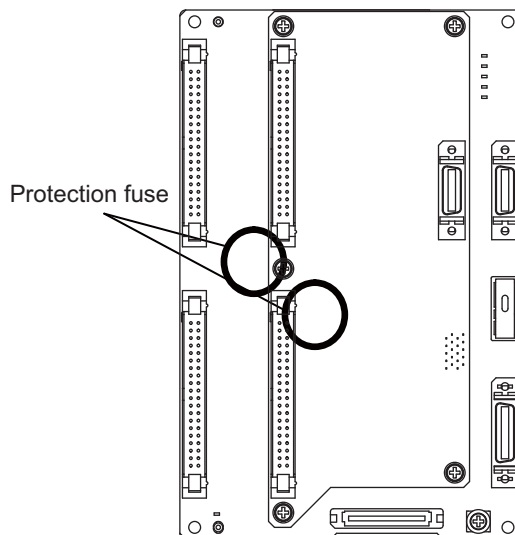

Replacements	Part type
Protection fuse	LM40

2.1.4 Key Sheet

The key sheet covering the sheet-key type keyboard can be replaced.
Remove the old key sheet as shown below, then place the new one.

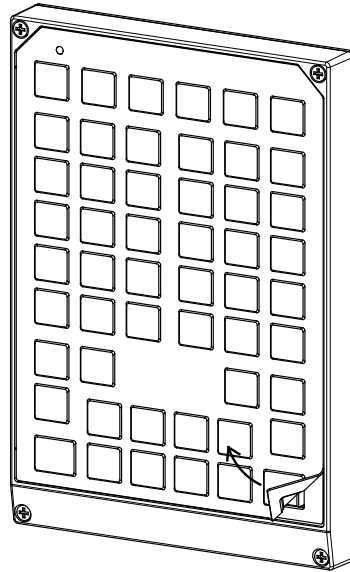

Key sheet for FCU7-KB024	N330B532G51
Key sheet for FCU7-KB025	N330B532G52

(Note 1) Clean the surface before placing the new key sheet.

(Note 2) The figure in the above is an example of FCU7-KB024. The keysheet for FCU7-KB025 can be removed in a similar way.

2.2 Control Unit

[Replacement procedures]

Always replace the control unit with the machine power turned OFF.

- (1) Check that the machine power is turned OFF. (If the power is not OFF, turn it OFF.)
- (2) Disconnect all the external cables from the control unit.
- (3) Disconnect all the internal cables from the control unit. (MENU, INV and LCD connectors)
(Note) Open the battery cover to disconnect the LCD connector.
- (4) Remove the screws fixing the control unit, and remove the control unit from the control unit installation fitting. (Loosen the two lower fixing screws first, and then remove one upper fixing screw while supporting the control unit with a hand. Then lift the control unit upward and take it off. The two lower fixing screws do not need to be removed.)
- (5) Install a new control unit onto the control unit installation fitting with fixing screws.
- (6) Connect all the cables back to the control unit. (Always connect the cables to the designated connectors.)
- (7) Confirm that all the cables are correctly connected and close the electric cabinet door.

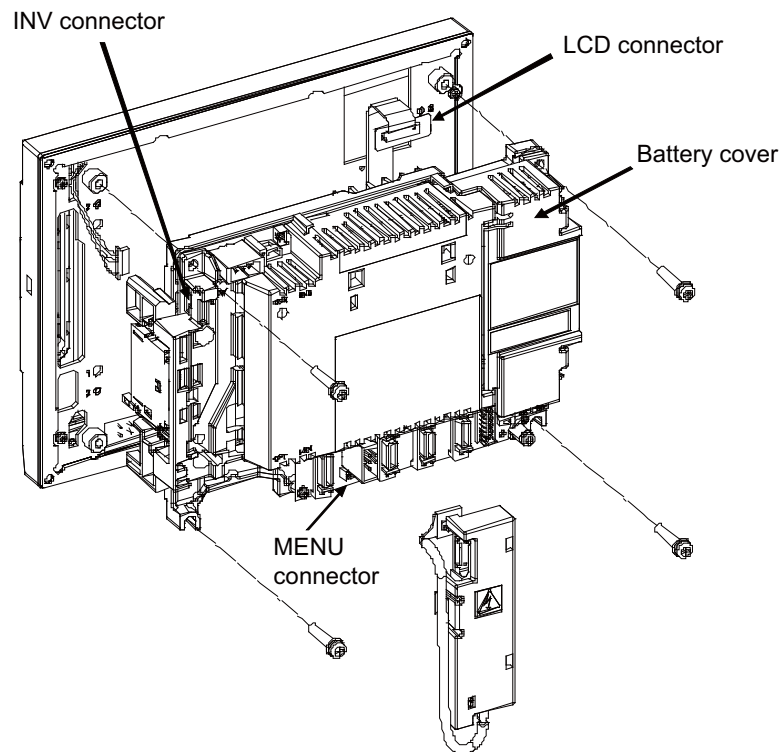

⚠ CAUTION

1. Incorrect connections could cause devices to damage. Connect the cables to designated connectors.
2. Do not replace the control unit while the power is ON.
3. Do not connect or disconnect the cables between units while the power is ON.

(Note) Wire the control unit optical cable as shown below. Refer to the Connection Manual when handling and wiring optical communication cable.

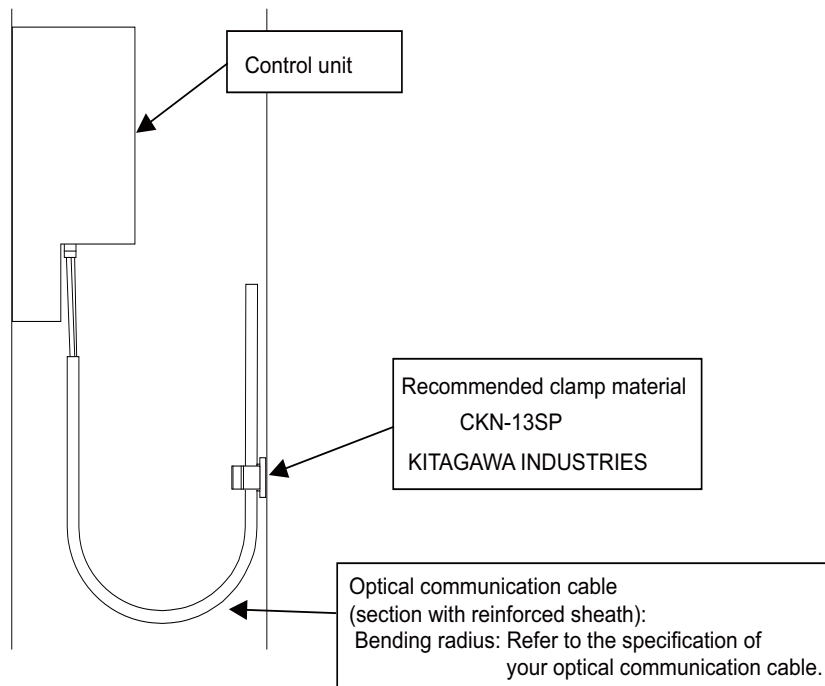

2.2.1 Installation on FCU7-DU120-13 (8.4-type)

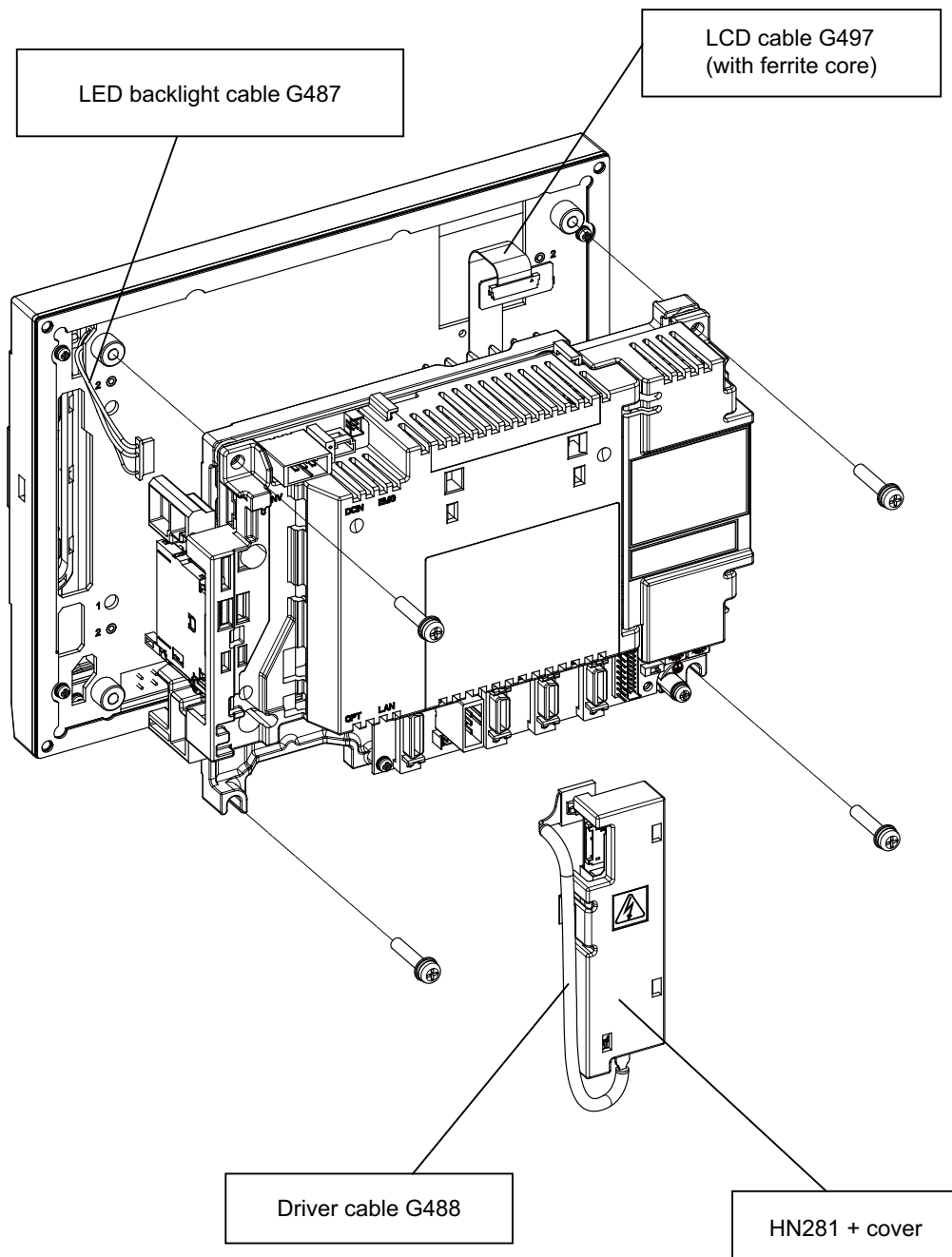

2.3 Display Unit

[Replacement procedures]

Always replace the display unit with the control unit (machine) power turned OFF.

- (1) Check that the machine power is turned OFF. (If the power is not OFF, turn it OFF.)
- (2) Open the electric cabinet door.
- (3) Disconnect all the cables connected to the display unit.
- (4) Remove the screws fixing the display unit (at 4 places) and take the display unit off.
- (5) Install a new display unit with fixing screws.
- (6) Connect all the cables back to the display unit. (Always connect the cables to the designated connectors.)
- (7) Confirm that all the cables are correctly connected and close the electric cabinet door.

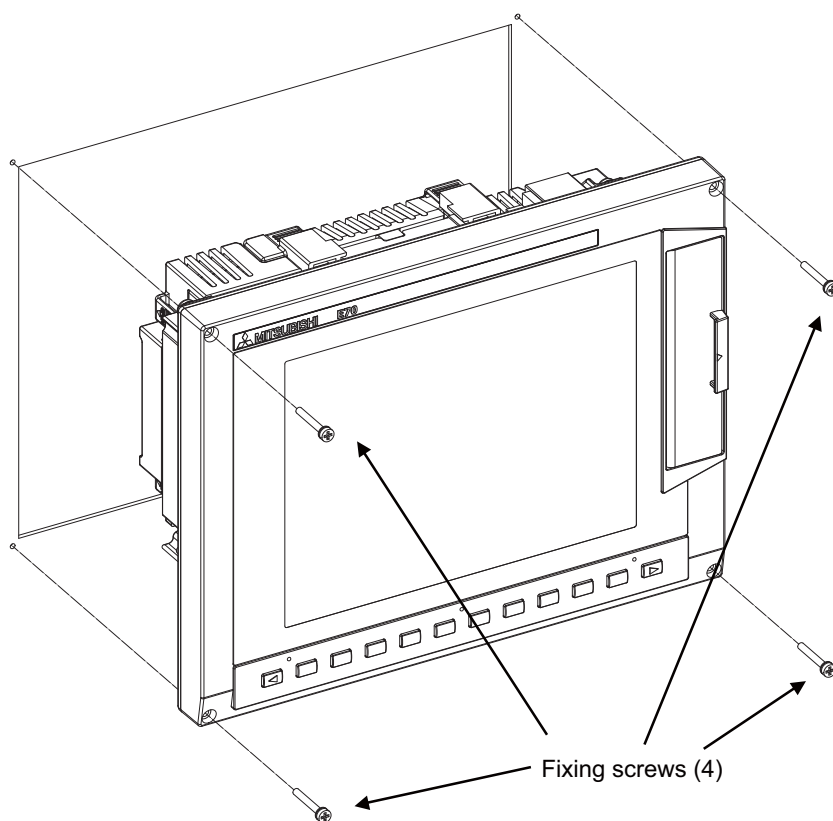

CAUTION

1. Incorrect connections could cause devices to damage. Connect the cables to designated connectors.
2. Do not replace the display unit while the power is ON.
3. Do not connect or disconnect the cables between units while the power is ON.

2.4 Keyboard Unit

[Replacement procedures]

Always replace the keyboard unit with the control unit (machine) power turned OFF.

- (1) Check that the machine power is turned OFF. (If the power is not OFF, turn it OFF.)
- (2) Open the electric cabinet door.
- (3) Disconnect all the cables connected to the keyboard unit.
- (4) Remove the screws fixing the keyboard unit and take the keyboard unit off.
- (5) Install a new keyboard unit with fixing screws.
- (6) Connect all the cables connected to the keyboard unit. (Always connect the cables to the designated connectors.)
- (7) Confirm that all the cables are correctly connected and close the electric cabinet door.

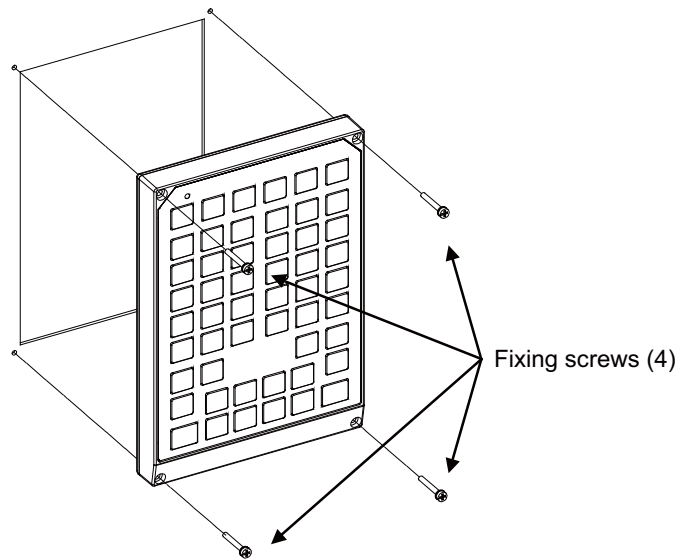

CAUTION

1. Incorrect connections could cause devices to damage. Connect the cables to designated connectors.
2. Do not replace the keyboard unit while the power is ON.
3. Do not connect or disconnect the cables between units while the power is ON.

2.5 Operation Panel I/O Unit

[Replacement procedures]

Always replace the operation panel I/O unit with the control unit (machine) power turned OFF.

- (1) Check that the machine power is turned OFF. (If the power is not OFF, turn it OFF.)
- (2) Open the electric cabinet door.
- (3) Disconnect all the cables connected to the operation panel I/O unit.
- (4) Remove the screws fixing the operation panel I/O unit, and take the unit off.
- (5) Install a new operation panel I/O unit with fixing screws. (Fix so that the NCKB connector slot is placed at the lower part.)
- (6) Connect all the cables back to the operation panel I/O unit. (Always connect the cables to the designated connectors.)

NCKB cable can be easily inserted by fitting the Δ 1st pin position with the connector.

- (7) Confirm that all the cables are correctly connected and close the electric cabinet door.

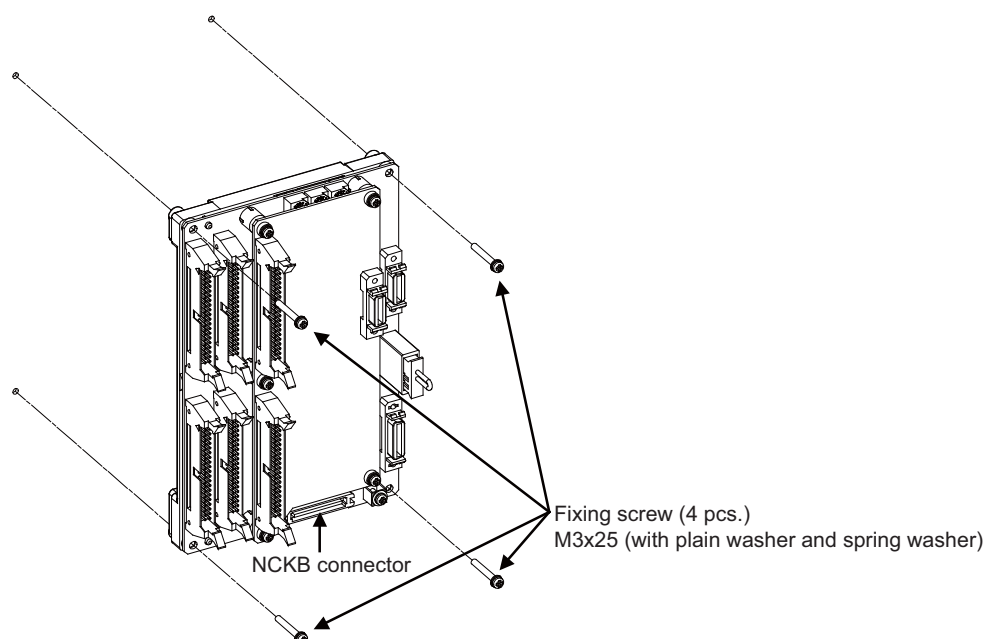

CAUTION

1. Incorrect connections could cause devices to damage. Connect the cables to designated connectors.
2. Do not replace the operation panel I/O unit while the power is ON.
3. Do not connect or disconnect the cables between units while the power is ON.

2.6 CompactFlash (CF) Card

[Card insertion procedures]

- (1) Open the card interface door on the display unit right end.
- (2) Insert the CF card. (Insert it so that the top surface faces to the observer's right or display side.)

[Card ejecting procedures]

- (1) Open the card interface door on the display unit right end.
- (2) Press the eject lever twice to eject the CF card.

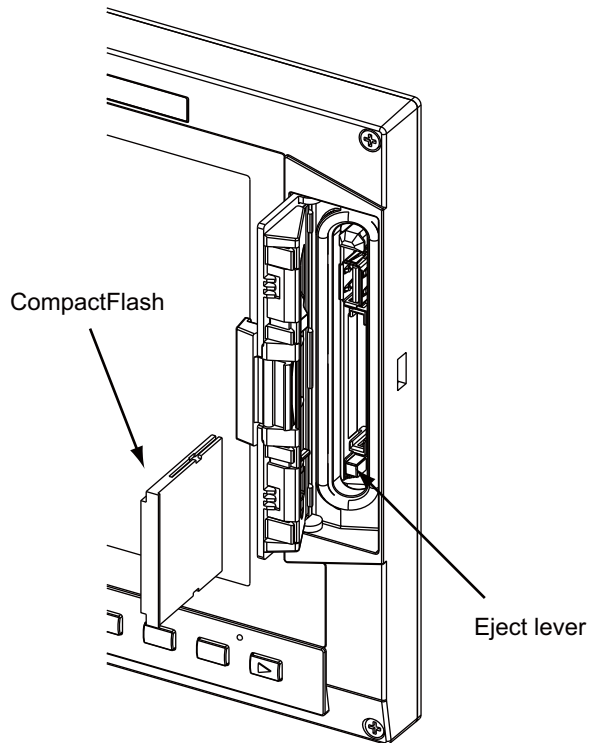

(Note 1) Do not eject a CF card during the data reading/writing.

(Note 2) It is recommended to use CF cards of the original equipment manufactured parts. MITSUBISHI is unable to guarantee the machine operation when a commercially available CF card is used. In that case, performance check must be made carefully by machine tool builder.

2.7 USB Memory

The USB memory slot is above the CF card interface.

Open the door located on the display unit right end and insert/remove the USB memory.

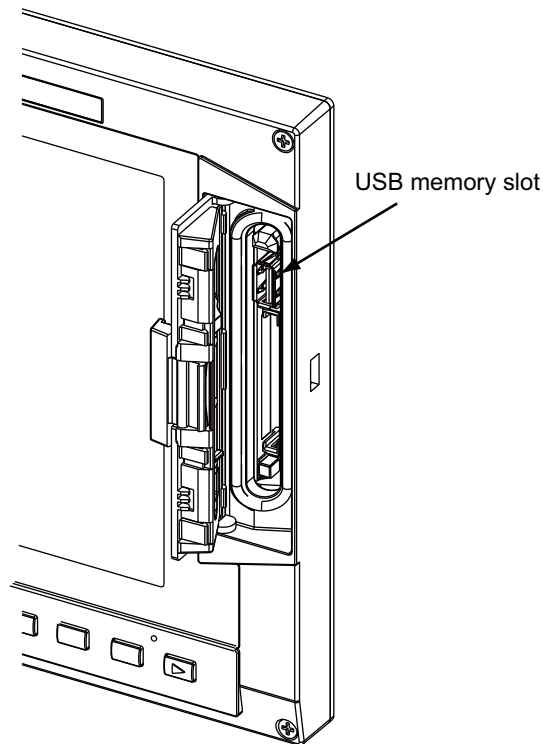

(Note 1) Do not remove a USB memory during the data reading/writing.

(Note 2) Do not connect a device other than USB memory. When using the commercially available USB memory, careful performance check must be required by the machine tool builder.

IV APPENDIXES

Appendix 1

List of Function Codes

Appendix 1 List of Function Codes

Function code	Control unit recognition	Subject to parity		Screen display	Setting and display unit		Stored in memory	Punch-output		Internal NC system function
		V count	Counted		Key-in	Key-in		ISO	ISO	
0 to 9	Yes	Counted	Counted	Displayed	Key-in	Key-in	Stored	0 to 9		Numerical data
A to Z	Yes	Counted	Counted	Displayed	Key-in	Key-in	Stored	A to Z		Addresses
+	Yes	Counted	Counted	Displayed	Key-in	Key-in	Stored	+		Sign, variable operator (+)
-	Yes	Counted	Counted	Displayed	Key-in	Key-in	Stored	-		Sign, variable operator (-)
.	Yes	Counted	Counted	Displayed	Key-in	Key-in	Stored	.		Decimal point
,	Yes	Counted	Counted	Displayed	Key-in	Key-in	Stored	,		
/	Yes	Counted	Counted	Displayed	Key-in	Key-in	Stored	/		Block delete (optional block skip) Variable operator (÷)
%	Yes	Counted	Counted	Displayed (%)	No key-in (automatically inserted)		Stored	%		End of record (tape storage end) Rewind start & stop during tape search
LF/NL	Yes	Counted	Counted	Displayed (:)	Key-in ;E/OB		Stored	LF		End of block
(Yes	Counted	Counted	Displayed	Key-in	Key-in	Stored	(Control out (comment start)
)	Yes	Counted	Counted	Displayed	Key-in	Key-in	Stored)		Control in (comment end)
:	Yes	Counted	Counted	Displayed	No key-in		Stored	:		Program number address (instead of O.)
#	Yes	Counted	Counted	Displayed	Key-in	Key-in	Stored	#		Variable number
*	Yes	Counted	Counted	Displayed	Key-in	Key-in	Stored	*		Variable operator (X)
=	Yes	Counted	Counted	Displayed	Key-in	Key-in	Stored	=		Variable definition
[Yes	Counted	Counted	Displayed	Key-in	Key-in	Stored	[Variable operator
]	Yes	Counted	Counted	Displayed	Key-in	Key-in	Stored]		Variable operator
BS	No			Not displayed	No key-in		Stored			
HT	No			Not displayed	No key-in		Stored			
SP	No			Not displayed	Key-in		Stored		SP(T-Vautomatic adjustment)	
CR	No			Not displayed	No key-in		Stored			
DEL	No	Not counted	Not counted	Not displayed	No key-in		Not stored			
NULL	No	Not counted	Not counted	Not displayed	No key-in		Not stored			
Any other	No	Counted	Counted	(Note 2)	No key-in		Stored			

(Note 1) Codes not listed in the above table are stored on tape, but an error will result during operation if they are not comments.
 (Note 2) This denotes characters (including blanks) which are stored inside and which correspond to the command codes. "@" is not displayed.

Appendix 2

Table of Command Value Ranges

<Table of command values and setting value ranges>

(1) Linear axis: Input increment [mm] (M system)

Least command increment	0.001	0.0001
Maximum stroke (value for machine coordinate system)	± 99999.999 mm	± 99999.9999 mm
Maximum programmable dimension	± 99999.999 mm	± 99999.9999 mm
Rapid traverse rate (including dry run)	1 to 1000000 mm/min	1 to 1000000 mm/min
Cutting feed rate (including dry run) Asynchronous feed (feed per minute)	0.001 to 1000000.000 mm/min	0.0001 to 1000000.0000 mm/min
Synchronous feed (feed per revolution)	0.001 to 999.999 mm/rev	0.0001 to 999.9999 mm/rev
2nd to 4th reference position compensation (value for machine coordinate system)	± 99999.999 mm	± 99999.9999 mm
Tool compensation amount (shape)	± 99999.999 mm	± 99999.9999 mm
Tool compensation amount (wear)	± 99999.999 mm	± 99999.9999 mm
Incremental feed amount	0.001 mm/pulse	0.0001 mm/pulse
Handle feed amount	0.001 mm/pulse	0.0001 mm/pulse
Soft limit range (value with machine coordinate system)	± 99999.999 mm	± 99999.9999 mm
Dwell time	0 to 99999.999 s	0 to 99999.9999 s
Backlash compensation amount	± 9999999 pulse	± 9999999 pulse
Pitch error compensation amount	-32768 to 32767 pulse	-32768 to 32767 pulse
Thread lead (F)	0.001 to 999.999 mm/rev	0.0001 to 999.9999 mm/rev
Thread lead (precision E)	0.0001 to 999.9999 mm/rev	0.00001 to 999.99999 mm/rev
Thread lead (ridges/inch)	0.03 to 999.99	0.026 to 222807.017

(2) Linear axis: Input increment [inch] (M system)

Least command increment	0.0001	0.00001
Maximum stroke (value for machine coordinate system)	± 9999.9999 inch	± 9999.99999 inch
Maximum programmable dimension	± 9999.9999 inch	± 9999.99999 inch
Rapid traverse rate (including dry run)	1 to 100000 inch/min	1 to 100000 inch/min
Cutting feed rate (including dry run) Asynchronous feed (feed per minute)	0.0001 to 100000.0000 inch/min	0.00001 to 100000.00000 inch/min
Synchronous feed (feed per revolution)	0.0001 to 999.9999 inch/rev	0.00001 to 999.99999 inch/rev
2nd to 4th reference position compensation (value for machine coordinate system)	± 9999.9999 inch	± 9999.99999 inch
Tool compensation amount (shape)	± 9999.9999 inch	± 9999.99999 inch
Tool compensation amount (wear)	± 9999.9999 inch	± 9999.99999 inch
Incremental feed amount	0.0001 inch/pulse	0.00001 inch/pulse
Handle feed amount	0.0001 inch/pulse	0.00001 inch/pulse
Soft limit range (value with machine coordinate system)	± 9999.9999 inch	± 9999.99999 inch
Dwell time	0 to 99999.999 s	0 to 99999.9999 s
Backlash compensation amount	± 9999999 pulse	± 9999999 pulse
Pitch error compensation amount	-32768 to 32767 pulse	-32768 to 32767 pulse
Thread lead (F)	0.0001 to 39.3700 inch/rev	0.00001 to 39.37007 inch/rev
Thread lead (precision E)	0.00001 to 39.37007 inch/rev	0.000001 to 39.370078 inch/rev
Thread lead (ridges/inch)	0.025 to 9999.999	0.0255 to 9999.9999

(3)Rotation axis: degree [°] (M system)

Least command increment	0.001	0.0001
Maximum stroke (value for machine coordinate system)	± 99999.999 °	± 99999.9999 °
Maximum programmable dimension	± 99999.999 °	± 99999.9999 °
Rapid traverse rate (including dry run)	1 to 1000000 ° /min	1 to 1000000 ° /min
Cutting feed rate (including dry run) Asynchronous feed (feed per minute)	0.001 to 1000000.000 ° /min	0.0001 to 1000000.0000 ° /min
Synchronous feed (feed per revolution)	0.001 to 999.999 ° /rev	0.0001 to 999.9999 ° /rev
2nd to 4th reference position compensation (value with machine coordinate system)	± 99999.999 °	± 99999.9999 °
Incremental feed amount	0.001 ° /pulse	0.0001 ° /pulse
Handle feed amount	0.001 ° /pulse	0.0001 ° /pulse
Soft limit range (value with machine coordinate system)	± 99999.999 °	± 99999.9999 °
Backlash compensation amount	± 9999999 pulse	± 9999999 pulse
Pitch error compensation amount	-32768 to 32767 pulse	-32768 to 32767 pulse

<Table of command values and setting value ranges>

(1)Linear axis: Input increment [mm] (L system)

Least command increment	0.001	0.0001
Maximum stroke (value for machine coordinate system)	± 99999.999 mm	± 99999.9999 mm
Maximum programmable dimension	± 99999.999 mm	± 99999.9999 mm
Rapid traverse rate (including dry run)	1 to 1000000 mm/min	1 to 1000000 mm/min
Cutting feed rate (including dry run) Asynchronous feed (feed per minute)	0.001 to 1000000.000 mm/min	0.0001 to 1000000.0000 mm/min
Synchronous feed (feed per revolution)	0.0001 to 999.9999 mm/rev	0.00001 to 999.99999 mm/rev
2nd to 4th reference position compensation (value for machine coordinate system)	± 99999.999 mm	± 99999.9999 mm
Tool compensation amount (shape)	± 99999.999 mm	± 99999.9999 mm
Tool compensation amount (wear)	± 99999.999 mm	± 99999.9999 mm
Incremental feed amount	0.001 mm/pulse	0.0001 mm/pulse
Handle feed amount	0.001 mm/pulse	0.0001 mm/pulse
Soft limit range (value with machine coordinate system)	± 99999.999 mm	± 99999.9999 mm
Dwell time	0 to99999.999 s	0 to99999.9999 s
Backlash compensation amount	± 9999999 pulse	± 9999999 pulse
Pitch error compensation amount	-32768 to 32767 pulse	-32768 to 32767 pulse
Thread lead (F)	0.0001 to 999.9999 mm/rev	0.00001 to 999.99999mm/rev
Thread lead (precision E)	0.00001 to 999.99999 mm/rev	0.000001 to 999.999999 mm/rev
Thread lead (ridges/inch)	0.03 to 999.99	0.026 to 222807.017

Appendix 2 Table of Command Value Ranges

(2)Linear axis: Input increment [inch] (L system)

Least command increment	0.0001	0.00001
Maximum stroke (value for machine coordinate system)	± 9999.9999 inch	± 9999.99999 inch
Maximum programmable dimension	± 9999.9999 inch	± 9999.99999 inch
Rapid traverse rate (including dry run)	1 to100000 inch/min	1 to100000 inch/min
Cutting feed rate (including dry run) Asynchronous feed (feed per minute)	0.0001 to 100000.0000 inch/min	0.00001 to 100000.00000 inch/min
Synchronous feed (feed per revolution)	0.00001 to 99.99999 inch/rev	0.000001 to 99.999999 inch/rev
2nd to 4th reference position compensation (value for machine coordinate system)	± 9999.9999 inch	± 9999.99999 inch
Tool compensation amount (shape)	± 9999.9999 inch	± 9999.99999 inch
Tool compensation amount (wear)	± 9999.9999 inch	± 9999.99999 inch
Incremental feed amount	0.0001 inch/pulse	0.00001 inch/pulse
Handle feed amount	0.0001 inch/pulse	0.00001 inch/pulse
Soft limit range (value with machine coordinate system)	± 9999.9999 inch	± 9999.99999 inch
Dwell time	0 to 99999.999 s	0 to 99999.9999 s
Backlash compensation amount	± 9999999 pulse	± 9999999 pulse
Pitch error compensation amount	-32768 to 32767 pulse	-32768 to 32767 pulse
Thread lead (F)	0.00001 to 39.37007inch/rev	0.000001 to 39.370078inch/rev
Thread lead (precision E)	0.000001 to 39.370078inch/rev	0.0000001 to 39.3700787inch/rev
Thread lead (ridges/inch)	0.025 to 9999.999	0.0254 to 9999.9999

(3)Rotation axis: degree [°] (L system)

Least command increment	0.001	0.0001
Maximum stroke (value for machine coordinate system)	$\pm 99999.999^\circ$	$\pm 99999.9999^\circ$
Maximum programmable dimension	$\pm 99999.999^\circ$	$\pm 99999.9999^\circ$
Rapid traverse rate (including dry run)	1 to 1000000 $^\circ$ /min	1 to 1000000 $^\circ$ /min
Cutting feed rate (including dry run) Asynchronous feed (feed per minute)	0.001 to 1000000.000 $^\circ$ /min	0.0001 to 1000000.0000 $^\circ$ /min
Synchronous feed (feed per revolution)	0.0001 to 999.9999 $^\circ$ /rev	0.00001 to 999.99999 $^\circ$ /rev
2nd to 4th reference position compensation (value with machine coordinate system)	$\pm 99999.999^\circ$	$\pm 99999.9999^\circ$
Incremental feed amount	0.001 $^\circ$ /pulse	0.0001 $^\circ$ /pulse
Handle feed amount	0.001 $^\circ$ /pulse	0.0001 $^\circ$ /pulse
Soft limit range (value with machine coordinate system)	$\pm 99999.999^\circ$	$\pm 99999.9999^\circ$
Backlash compensation amount	± 9999999 pulse	± 9999999 pulse
Pitch error compensation amount	-32768 to 32767 pulse	-32768 to 32767 pulse

Appendix 3

Circular Cutting Radius Error

When circular cutting is performed, an error is caused between the command coordinate and the tracking coordinate due to the tracking delay in the smoothing circuit and servo system, and the workpiece ends up with a radius smaller than the commanded value. The method for obtaining this error (radius error) is shown below.

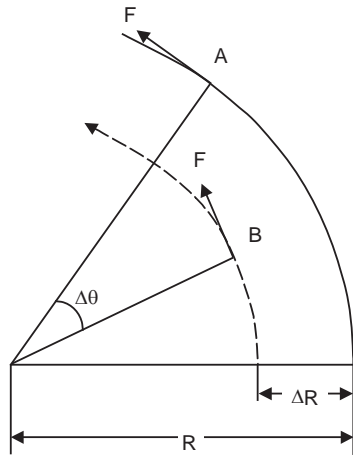

- A : Command coordinate
- B : Tracking coordinate
- R : Command radius (mm)
- ΔR : Radius error (mm)
- Δθ : Angle error (rad)
- F : Cutting feed rate (m/min)

The radius error R and angle error are calculated from the following formula.

Exponential acceleration/deceleration	$\Delta R = \frac{1}{R} \cdot \left(\frac{1}{2} T_s^2 + \frac{1}{2} T_p^2 \right) \cdot \left(\frac{F \times 10^3}{60} \right)^2 \text{ (mm)}$
Linear acceleration/deceleration	$\Delta R = \frac{1}{R} \cdot \left(\frac{1}{24} T_s^2 + \frac{1}{2} T_p^2 \right) \cdot \left(\frac{F \times 10^3}{60} \right)^2 \text{ (mm)}$

$$\Delta \theta = \tan^{-1} \left(T_s \cdot \frac{F}{R} \right) + \tan^{-1} \left(T_p \cdot \frac{F}{R} \right) \text{ (rad)}$$

Ts: Time constant (s) of specified smoothing circuit
 Tp: Position loop time constant

- (Note 1) When the ΔR radius error applying with circular cutting does not come within the allowable value, proceed to reduce the cutting feed rate F, set Ts to a lower value or review the program.
- (Note 2) In the steady state, ΔR is constant. However, it is not constant with command start and stop transitions. Under command start and stop conditions, therefore, the tracking coordinate should be as shown in the figure below.

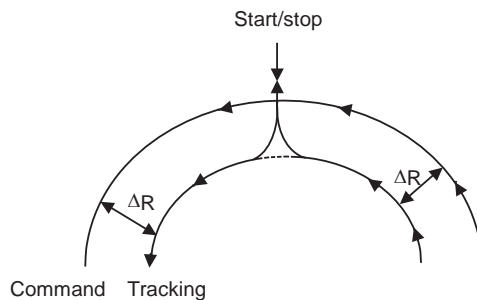

Appendix 4

Registering/Editing the Fixed Cycle Program

The subprogram for the fixed cycle can be input, output and edited.

 **CAUTION**

 Do not change the fixed cycle program without prior approval from the machine maker.

Appendix 4.1 Fixed Cycle Operation Parameters

To input/output or edit the data of each fixed cycle subprogram, use the Data I/O and Edit screens in the same way as when creating usual user-created work programs. In this case, the parameters must have been set. Set "1" in parameter "#1166 fixpro". If this parameter is valid, the IN/OUT and Edit screens are usable only for operating a fixed cycle control subprogram. During this period, program file displays only fixed cycle programs. Thus, after fixed cycle program operation, return parameter to "0".

(Note) Parameter "#1166 fixpro" will be set to 0 when the power is turned OFF.

Appendix 4.2 Transmitting/Erasing the Fixed Cycle Program

Transmit/erase the fixed cycle program from the Data I/O screen. Check that fixed cycle operation parameter "#1166 fixpro" is valid.

The operating procedure is the same as a user machining program.

Appendix 4.3 Standard Fixed Cycle Subprogram (For L system)

[G37(O100000370) Automatic tool length measurement]

```
G31 Z#5 F#3 ;
IF [ROUND[ABS[#2-[##10*#11-#12]]] GT #8] GOTO 1 ;
IF [ROUND[##10*#11-#12] EQ #4] GOTO 1 ;
##9 = ##10-#12/#11-#2/#11+##9 ;
#3003 = #1 ;
N2 ;
M99 ;
N1 #3901 = 126 ;
```

[G74(O100000740) End face cutoff cycle]

```
G.1 ;
IF [ABS[#2] GT 0] GOTO 10 ;
#14 = 1 ;
N10 #13 = #3 ;
IF [#15 NE 0] GOTO 11 ;
#13 = #3-#5 ;
N11 #16 = 0 ;
DO1 ;
#10 = 0 ;
#11 = #4 ;
DO2 ;
#10 = #10+#4 ;
IF [ABS[#10] GE [ABS[#1]]] GOTO 1 ;
G01 X#11 ;
G00 X#6 ;
#11 = #4-#6 ;
END2 ;
N1 G01 X#1-#10+#11 ;
IF [#15 EQ 0] GOTO 20 ;
IF [#16 EQ 0] GOTO 21 ;
N20 G00 Y#5 ;
N21 #16 = 1 ;
G00 X-#1 ;
IF [#14] GOTO 3 ;
#12 = #12+#3 ;
IF [ABS[#12] LT [ABS[#2]]] GOTO 2 ;
#14 = 1 ;
#13 = #2-#12+#13 ;
N2 G00 Y#13 ;
#13 = #3-#5 ;
END1 ;
N3 G00 Y-#2-#5 ;
M99 ;
```

```

[G75(O 100000750) Longitudinal cutting cycle]
G.1 ;
IF [ABS[#1] GT 0] GOTO 10 ;
#14 = 1 ;
N10 #13 = #4 ;
IF [#15 NE 0] GOTO 11 ;
#13 = #4-#5 ;
N11 #16 = 0 ;
DO1 ;
#10 = 0 ;
#11 = #3 ;
DO2 ;
#10 = #10+#3 ;
IF [ABS[#10] GE [ABS[#2]]] GOTO 1 ;
G01 Y#11 ;
G00 Y#6 ;
#11 = #3-#6 ;
END2 ;
N1 G01 Y#2-#10+#11 ;
IF [#15 EQ 0] GOTO 20 ;
IF [#16 EQ 0] GOTO 21 ;
N20 G00X#5 ;
N21 #16 = 1 ;
G00 Y-#2 ;
IF [#14] GOTO 3 ;
#12 = #12+#4 ;
IF [ABS[#12] LT [ABS[#1]]] GOTO 2 ;
#14 = 1 ;
#13 = #1-#12+#13 ;
N2 G00X#13 ;
#13 = #4-#5 ;
END1 ;
N3 G00X-#1-#5 ;
M99 ;
    
```

```

[G76(O 100000760) Compound thread cutting cycle]
G.1 ;
#12 = 1 ;
#13 = #9 ;
IF [ABS[#13] GE [ABS[#8]]] GOTO 1 ;
#16 = 1 ;
#13 = #8 ;
N1#11 = #13 ;
IF [ABS[#11] LT [ABS[#4-#5]]] GOTO 2 ;
#11 = #4-#5 ;
#14 = 1 ;
N2 #17 = #11 ;
#10 = ROUND[#11+#5] * #7 ;
IF [[#10 XOR #1] GE 0] GOTO 20 ;
#10 = -#10 ;
N20 G00 X#10 ;
#55 = #10 ;
DO1 ;
#15 = ROUND[#10*#3/#1] ;
N90 #40 = 90 #41 = #5001 #42 = #5002 ;
G00 Y#2+#3-#4-#15+#11 ;
G33 X#1-#10Y-#3+#15 Q#22 M96.101 P1000D3 ;
G00 Y-#2+#4-#11 M97.101 ;
IF [#14 GT 0] GOTO 3 ;
IF [#16 GT 0] GOTO 7 ;
#12 = #12+1 ;
#13 = ROUND[#9*SQRT[#12]] ;
IF [ABS[#13-#11] GE [ABS[#8]]] GOTO 8 ;
#16 = 1 ;
N7 #13 = #11+#8 ;
N8 #11 = #13 ;
IF [ABS[#11] LT [ABS[#4-#5]]] GOTO 9 ;
#11 = #4-#5 ;
#14 = 1 ;
N9 #10 = ROUND[#17-#11]*#7 ;
IF [[#10 XOR #1] GE 0]GOTO 6 ;
#10 = -#10 ;
N6 #10 = #10+#55 ;
G00 X-#1+#10 ;
N12 END1 ;
N3 IF [ABS[#6] LT 1] GOTO 5 ;
#14 = 0 ;
#13 = 0 ;
DO2 ;
IF [#14 GT 0]GOTO 5 ;
#13 = #13+#6 ;
IF [ABS[#13] LT [ABS[#5]]] GOTO 4 ;
#13 = #5 ;
#14 = 1 ;
N4 G00 X#10-#1 ;
N91 #40 = 91 #41 = #5001 #42 = #5002 ;
G00 Y#2+#3-#4+#13-#15+#11 ;
G33 X#1-#10 Y-#3+#15 Q#22 M96.101 P1000 D3 ;
G00 Y-#2+#4-#13-#11 M97.101 ;
END2 ;
N5 G00 X-#1 ;
M99 ;

```

[G77(O10000770) Longitudinal cutting cycle]

```
G.1 ;
IF [#1 EQ 0] OR [#2 EQ 0]] GOTO 1 ;
Y#2+#7 ;
G1 X#1 Y-#7 ;
Y-#2 ;
G0 X-#1 ;
N1 M99 ;
```

[G78(O10000780) Thread cutting cycle]

```
G.1 ;
IF [#1 EQ 0] OR [#2 EQ 0]] GOTO 1 ;
N90 #40 = 90 #41 = #5001 #42 = #5002 ;
Y #2+#7 ;
G33 X#1 Y-#7 F#9 E#10 Q#20 M96.101 P1000 D3 ;
G0 Y-#2 M97.101 ;
X-#1 ;
N1 M99 ;
```

[G79(O10000790) End face cutoff cycle]

```
G.1 ;
IF [#1 EQ 0] OR [#2 EQ 0]] GOTO 1 ;
X#1+#7 ;
G1 X-#7 Y#2 ;
X-#1 ;
G0 Y-#2 ;
N1 M99 ;
```

[G83, G87(O10000830) Deep hole drilling cycle B]

```
G.1 ;  
IF [#30] GOTO 2 ;  
M#24 ;  
#29 = #11 #28 = 0 ;  
Z#2 ;  
#2 = ##5 #3003 = #8 OR 1 ;  
DO1 ;  
#28 = #28-#11 #26 = -#28-#29 ;  
Z#26 ;  
IF [ABS[#28] GE [ABS[#3]]] GOTO 1 ;  
G1 Z#29 ;  
G0 Z#28 ;  
#29 = #11+#14 ;  
END1 ;  
N1 G1 Z#3-#26 ;  
G4 P#4 ;  
#3003 = #8 ;  
G0 Z-#3-#2 ;  
IF [#24 EQ #0] GOTO 2 ;  
M#24+1 ;  
G4 P#56 ;  
N2 M99 ;
```

[G83, G87(O10000831) Deep hole drilling cycle A]

```
G.1 ;  
IF [#30] GOTO 2 ;  
M#24 ;  
#29 = 0 #28 = #11 ;  
Z#2 ;  
#2 = ##5 #3003 = #8 OR 1 ;  
DO1 ;  
#29 = #29+#11 ;  
IF [ABS[#29] GE [ABS[#3]]] GOTO 1 ;  
G1 Z#28 ;  
G0 Z-#14 ;  
#28 = #11+#14 ;  
END1 ;  
N1 G1 Z#3-#29+#28 ;  
G4 P#4 ;  
#3003 = #8 ;  
G0 Z-#3-#2 ;  
IF [#24 EQ #0] GOTO 2 ;  
M#24+1 ;  
G4 P#56 ;  
N2 M99 ;
```

```

[G83.2(O10000832) Deep hole drilling cycle 2]
G.1 ;
IF [#30] GOTO 3 ;
#3003 = #8 OR 1 ;
#29 = #12 #28 = 0 #26 = 0 ;
G0 Z#2 ;
IF [#12 NE #0] GOTO 1 ;
IF [#11 EQ #0] GOTO 2 ;
N1 #28 = #28-#12 #26 = -#28-#29 ;
IF [ABS[#28] GE [ABS[#3]]] GOTO 2 ;
G1 Z#12 ;
G4 P#4 ;
G0 Z#28-#2 ;
G4 P#13 ;
#29 = #11+#15 ;
DO1 ;
#28 = #28-#11 #26 = -#28-#29 ;
G0 Z#26+#2 ;
IF [ABS[#28] GE [ABS[#3]]] GOTO 2 ;
G1 Z#29 ;
G4 P#4 ;
G0 Z#28-#2 ;
G4 P#13 ;
END1 ;
N2 G1 Z#3-#26 ;
G4 P#4 ;
#3003 = #8 ;
G0 Z-#3-#2 ;
N3 M99 ;
    
```

[G84, G88(O 10000840) Tap cycle]

```
G.1 ;  
IF [#30] GOTO 2 ;  
M#24 ;  
Z#2 ;  
#2 = ##5 #3003 = #8 OR 1 #3004 = #9 OR 3 ;  
G1 Z#3 ;  
G4 P#4 ;  
M#53 ;  
#3900 = 1 ;  
G1 Z-#3 ;  
#3004 = #9 ;  
M#54 ;  
#3003 = #8 ;  
IF [#24 EQ #0] GOTO 1 ;  
M#24+1 ;  
G4 P#56 ;  
N1 G0 Z-#2 ;  
N2 M99 ;
```

[G85, G89(O 10000850) Boring cycle]

```
G.1 ;  
IF [#30] GOTO 2 ;  
M#24 ;  
Z#2 ;  
#2 = ##5 #3003 = #8 OR 1 ;  
G1 Z#3 ;  
G4 P#4 ;  
#3003 = #8 ;  
Z-#3 F#23 ;  
F#22 ;  
IF [#24 EQ #0] GOTO 1 ;  
M#24+1 ;  
G4 P#56 ;  
N1 G0 Z-#2 ;  
N2 M99 ;
```

Appendix 4.4 Standard Fixed Cycle Subprogram (For M system)

[G81(O100000810) Drill, spot drill]

```
G.1 ;
IF [#30] GOTO 1 ;
Z#2 G#6 H#7 ;
#2 = ##5 #3003 = #8 OR 1 ;
G1 Z#3 ;
IF [#4 EQ #0] GOTO 2 ;
G4 P#4 ;
N2 ;
#3003 = #8 ;
G0 Z-#3-#2,l#23 ;
N1 M99 ;
%
```

[G82(O100000820) Drill, counter boring]

```
G.1 ;
IF [#30] GOTO 1 ;
Z#2 G#6 H#7 ;
#2 = ##5 #3003 = #8 OR 1 ;
G1 Z#3 ;
G4 P#4 ;
#3003 = #8 ;
G0 Z-#3-#2,l#23 ;
N1 M99 ;
%
```

[G83(O100000830) Deep hole drill cycle]

```
G.1 ;
IF [#30] GOTO 2 ;
#29 = #11 #28 = 0 ;
Z#2 G#6 H#7 ;
#2 = ##5 #3003 = #8 OR 1 ;
DO1 ;
#28 = #28-#11 #26 = -#28-#29 ;
Z#26 ;
IF [ABS[#28] GE [ABS[#3]]] GOTO 1 ;
G1 Z#29 ;
G0 Z#28 ;
#29 = #11+#14 ;
END1 ;
N1 G1 Z#3-#26 ;
IF [#4 EQ #0] GOTO 3 ;
G4 P#4 ;
N3 ;
#3003 = #8 ;
G0 Z-#3-#2,l#23 ;
N2 M99 ;
%
```

[G84(O10000840) Tap cycle]

```
G.1 ;
F [#30] GOTO 9 ;
Z#2 G#6 H#7 ;
#2 = ##5 #3003 = #8 OR 1 #3004 = #9 OR 3 ;
IF [#11] GOTO 1 ;
GOTO 2 ;
N1 ;
IF [#14] GOTO 5 ;
N2 G1 Z#3 ;
GOTO 7 ;
N5 ;
#29 = 0 #28 = #11 ;
DO1 ;
#29 = #29+#11 ;
IF [ABS[#29] GE [ABS[#3]]] GOTO 6 ;
G1 Z#28 ;
M#53 ;
G1 Z-#14 ;
M#54 ;
#28 = #11+#14 ;
END1 ;
N6 G1 Z#3-#29+#28 ;
N7 G4 P#4 ;
M#53 ;
#3900 = 1 ;
G1 Z-#3 ;
#3004 = #9 ;
G4 P#56 ;
M#54 ;
#3003 = #8 ;
G0 Z-#2,I#23 ;
N9 M99 ;
%
```

[G85(O10000850) Boring 1]

```
G.1 ;
IF [#30] GOTO 1 ;
Z#2 G#6 H#7 ;
#2 = ##5 #3003 = #8 OR 1 ;
G1 Z#3 ;
IF [#4 EQ #0] GOTO 2 ;
G4 P#4 ;
N2 ;
#3003 = #8 ;
Z-#3 ;
G0 Z-#2,I#23 ;
N1 M99 ;
%
```

[G86(O10000860) Boring 2]

```
G.1 ;
IF [#30] GOTO 1 ;
Z#2 G#6 H#7 ;
#2 = ##5 #3003 = #8 OR 1 ;
G1 Z#3 ;
G4 P#4 ;
M5 ;
G0 Z-#3-#2 ;
#3003 = #8 ;
M3 ;
N1 M99 ;
%
```

[G87(O 100000870) Back boring]

```
G.1 ;
IF [#30] GOTO 1 ;
#3003 = #8 OR 1 ;
M19 ;
X#12 Y#13 ;
#3003 = #8 ;
Z#2 G#6 H#7 ;
#3003 = #8 OR 1 ;
G1 X-#12 Y-#13 ;
#3003 = #8 ;
M3 ;
#3003 = #8 OR 1 ;
Z#3 ;
M19 ;
G0 X#12 Y#13 ;
Z-#2-#3 ;
#3003 = #8 ;
X-#12 Y-#13 ;
M3 ;
N1 M99 ;
%
```

[G88(O 100000880) Boring 3]

```
G.1 ;
IF [#30] GOTO 1 ;
Z#2 G#6 H#7 ;
#2 = ##5 #3003 = #8 OR 1 ;
G1 Z#3 ;
G4 P#4 ;
#3003 = #8 ;
M5 ;
#3003 = #8 OR 1 ;
G0 Z-#3-#2 ;
#3003 = #8 ;
M3 ;
N1 M99 ;
%
```

[G89(O10000890) Boring 4]

```
G.1 ;  
IF [#30] GOTO 1 ;  
Z#2 G#6 H#7 ;  
#2 = ##5 #3003 = #8 OR 1 ;  
G1 Z#3 ;  
G4 P#4 ;  
#3003 = #8 ;  
Z-#3 ;  
G0 Z-#2,l#23 ;  
N1 M99 ;  
%
```

[G73(O10000831) Step cycle]

```
G.1 ;  
IF [#30] GOTO 2 ;  
#29 = 0 #28 = #11 ;  
Z#2 G#6 H#7 ;  
#2 = ##5 #3003 = #8 OR 1 ;  
DO1 ;  
#29 = #29+#11 ;  
IF [ABS[#29] GE [ABS[#3]]] GOTO 1 ;  
G1 Z#28 ;  
G4 P#4 ;  
G0 Z-#14 ;  
#28 = #11+#14 ;  
END1 ;  
N1 G1 Z#3-#29+#28 ;  
G4 P#4 ;  
#3003 = #8 ;  
G0 Z-#3-#2,l#23 ;  
N2 M99 ;  
%
```

[G74(O10000841) Reverse tap cycle]

```
G.1 ;
IF [#30] GOTO 9 ;
Z#2 G#6 H#7 ;
#2 = ##5 #3003 = #8 OR 1 #3004 = #9 OR 3 ;
IF [#11] GOTO 1 ;
GOTO2 ;
N1 ;
IF [#14] GOTO 5 ;
N2 G1 Z#3 ;
GOTO 7 ;
N5 ;
#29 = 0 #28 = #11 ;
DO1 ;
#29 = #29+#11 ;
IF [ABS[#29] GE [ABS[#3]]] GOTO 6 ;
G1 Z#28 ;
M#53 ;
G1 Z-#14 ;
M#54 ;
#28 = #11+#14 ;
END1 ;
N6 G1 Z#3-#29+#28 ;
N7 G4 P#4 ;
M#53 ;
#3900 = 1 ;
G1Z-#3 ;
#3004 = #9 ;
G4 P#56 ;
M#54 ;
#3003 = #8 ;
G0 Z-#2,I#23 ;
N9 M99 ;
%
```

[G75(O10000851) Circle cutting cycle]

```
G.1 ;
IF [#30] GOTO 1 ;
#28 = #18 ;
IF [#28 GE 0] GOTO 2 ;
#27 = 3#28 = -#28 ;
GOTO 3 ;
N2 #27 = 2 ;
N3 #26 = #4 ;
IF [#26 GE #28] GOTO 1 ;
Z#2 G#6 H#7 ;
#2 = ##5 #3003 = #8 OR 1 ;
G1 Z#3 ;
#28 = #28-#26 #29 = #28/2 ;
G#27 X-#28 I-#29 ;
I#28 P1 ;
X#28 I#29 ;
#3003 = #8 ;
G0 Z-#3-#2,I#23 ;
N1 M99 ;
%
```

[G76(O100000861) Fine boring]

```
G.1 ;  
IF [#30] GOTO 1 ;  
Z#2 G#6 H#7 ;  
#2 = ##5 #3003 = #8 OR 1 ;  
G1 Z#3 ;  
M19 ;  
X#12 Y#13 ;  
G0 Z-#3-#2 ;  
#3003 = #8 ;  
X-#12 Y-#13 ;  
M3 ;  
N1 M99 ;  
%
```

Appendix 5

RS-232C I/O Device Parameter Setting Examples

Parameter setting examples	Cable connection					Follows communication protocol. (NC side) 2:SD 3:RD 4:RS 5:CS 6:DR 20:ER 7:GND
	NC I/O	NC I/O	NC I/O	NC I/O	NC I/O	
DEVICE NAME						Follows communication software.
BAUD RATE	2	2	2	2	2	
STOP BIT	3	3	3	3	3	
PARITY EFFECTIVE	0	0	0	0	0	
EVEN PARITY	0	0	0	0	0	
CHR. LENGTH	3	3	3	3	3	
HAND SHAKE	3	2	3	3	3	
DC CODE PARITY	1	0	1	1	1	
DC2/DC4 OUTPUT	0	0	1	0	1	
CR OUTPUT	0	0/1	0	0	0	
FEED CHR.	0	0	0	0	0	
PARITY V	0	0	0	0/1	0/1	
TIME-OUT SET	100	100	100	100	100	

Appendix 6

Explanation of Alarms

(Note) This alarm description is common for M700V/M70V/E70 Series.

It is written on the assumption that all option functions are added.

Confirm with the specifications issued by the machine tool builder before starting use.

Appendix 6.1 Operation Errors (M)

M01 Dog overrun 0001

Details

When returning to the reference position, the near-point detection limit switch did not stop over the dog, but overran the dog.

Remedy

- Increase the length of the near-point dog.
- Reduce the reference position return speed.

M01 Some ax does not pass Z phase 0002

Details

One of the axes did not pass the Z-phase during the initial reference position return after the power was turned ON.

Remedy

- Move the detector one rotation or more in the opposite direction of the reference position, and repeat reference position return.

M01 R-pnt direction illegal 0003

Details

When manually returning to the reference position, the return direction differs from the axis movement direction selected with the AXIS SELECTION key.

Remedy

- The selection of the AXIS SELECTION key's +/- direction is incorrect. The error is canceled by feeding the axis in the correct direction.

M01 External interlock axis exists 0004

Details

The external interlock function has activated (the input signal is "OFF") and one of the axes has entered the interlock state.

Remedy

- As the interlock function has activated, release it before resuming operation.
- Correct the sequence on the machine side.
- Check for any broken wires in the "interlock" signal line.

M01 Internal interlock axis exists 0005

Details

The internal interlock state has been entered.

The absolute position detector axis has been removed.

A command for the manual/automatic simultaneous valid axis was issued from the automatic mode.

The manual speed command was issued while the "tool length measurement 1" signal is ON.

A travel command has been issued to an inclined axis whose base axis is in control axis synchronization across part systems.

Selected an axis other than the 1st axis when the manual speed command was issued.

Remedy

- The servo OFF function is valid, so release it first.
- An axis that can be removed has been issued, so perform the correct operations.
- The command is issued in the same direction as the direction where manual skip turned ON, so perform the correct operations.
- During the manual/automatic simultaneous mode, the axis commanded in the automatic mode became the manual operation axis. Turn OFF the "manual/automatic valid" signal for the commanded axis.
- Turn ON the power again, and perform absolute position initialization.
- Turn OFF the "tool length measurement 1" signal to start the program by the manual speed command.
- Cancel the control axis synchronization across part systems, then issue a travel command to the inclined axis.
- Select the 1st axis of each part system when issuing the manual speed command.

M01 H/W stroke end axis exists 0006

Details

The stroke end function has activated (the input signal is "OFF") and one of the axes is in the stroke end status.

Remedy

- Move the machine manually.
- Check for any broken wires in the "stroke end" signal line.
- Check for any limit switch failure.

M01 S/W stroke end axis exists 0007

Details

The stored stroke limit I, II, IIB or IB function has activated.

Remedy

- Move the machine manually.
- Correct any setting error of the parameters for the stored stroke limit.

M01 Chuck/tailstock stroke end ax 0008

Details

The chuck/tail-stock barrier function turned ON, and an axis entered the stroke end state.

Remedy

- Reset the alarm with reset, and move the machine in the reverse direction.

M01 Ref point return No. invalid 0009

Details

2nd reference position return was performed before 1st reference position return has been completed.

Remedy

- Execute 1st reference position return.

M01 Illegal op in mid pt sg block 0013

Details

The operation mode was changed to MDI during single block stop at the middle point of G28/G29/G30.

Remedy

- Change the operation mode.
- Reset to clear the alarm.

M01 Sensor signal illegal ON 0019

Details

The sensor signal was already ON when the "tool length measurement 1" signal was validated. The sensor signal turned ON when there was no axis movement after the "tool length measurement 1" signal was validated.

The sensor signal turned ON at a position within 100 μ m from the final entry start position.

Remedy

- Disable the "tool length measurement 1" signal and move the axis in a safe direction.
- Disabling the sensor signal also clears the operation alarm.

(Note) When the "tool length measurement 1" signal is disabled, the axis can be moved in either direction. Pay attention to the movement direction.

M01 Ref point retract invalid 0020

Details

Reference position retract was performed while the coordinates had not been established.

Remedy

- Execute reference position return.

M01 Tool ofs invld after R-pnt 0021

Details

Reference position return had been performed during the tool retract and return, which invalidated the tool compensation amount after the reference position return.

Remedy

- The error is cleared if the operation mode is changed to other than reference position return before the axis performs reference position return.
- The error is cleared when the tool return is completed.
- The error is cleared if reset 1 is input or the emergency stop button is pushed.

M01 R-pnt ret invld at abs pos alm 0024

Details

A reference position return signal was enabled during an absolute position detection alarm.

Remedy

- Reset the absolute position detection alarm, and then perform the reference position return.

M01 R-pnt ret invld at zero pt ini 0025

Details

A reference position return signal was input during zero point initialization of the absolute position detection system.

Remedy

- Complete the zero point initialization, and then perform reference position return.

M01 High-accuracy skip disabled 0028

Details

The drive unit's hardware or software does not conform to the high-accuracy skip.

Remedy

- The software or hardware does not conform to the function. Contact service center.

M01 Hi-ac skip coord retrieval err 0029

Details

Failed to retrieve the skip coordinate value from the drive unit.

Remedy

- Check the wiring.
- Check the parameters.

M01 Now skip on 0030

Details

The "skip input" signal remains enabled when the operation has shifted from skip retract to measurement.

Remedy

- Increase the skip retract amount.

M01 No skip 0031

Details

Even though the 1st skip was to the correct position, the 2nd skip could not be found.

Remedy

- Check whether the measurement target has moved.

M01 Rtn dir err in manual measure 0033

Details

Return direction in manual measurement is the opposite of the parameter setting.

Remedy

- Check and correct the "#2169 Man meas rtn dir (Return direction in manual measurement)" setting.
- Move the axis manually to a safe position in the direction set by "#2169 Man meas rtn dir (Return direction in manual measurement)", then reset.

M01 Movement prohibited during tool retract 0035

Details

An axis movement was attempted from the tool retract position.
The movement was attempted by a manual command in the tool return.

Remedy

It is not allowed to move an axis arbitrarily from the tool retract position. Take the following steps to move the axis.

- Cancel the program execution by reset.
 - Use the tool escape and retract function and let the axis escape from the tool retract position.
- The interruption by a manual command is not allowed in a tool return. Take the following step to move the axis.
- Cancel the program execution by reset.

M01 Chopping axis R-pnt incomplete 0050

Details

Chopping mode has been entered while the chopping axis has not completed reference position return.
All axes interlock has been applied.

Remedy

- Reset the NC or disable the "chopping" signal, and then carry out the reference position return.

M01 Synchronous error excessive 0051

Details

The synchronization error of the primary and secondary axes exceeded the allowable value under synchronous control. A deviation exceeding the synchronization error limit value was found with the synchronization deviation detection.

Remedy

- Select the correction mode and move one of the axes in the direction in which the errors are reduced.
- Increase "#2024 synerr(allowable value)" or set "0" to disable error check.
- When using simple C-axis synchronous control, set "0" for "synchronous control operation method".

M01 No spindle select signal 0053

Details

Synchronous tapping command was issued when the "spindle selection" signals for all spindles were OFF in the multiple-spindle control II.

Remedy

- Turn ON the "spindle selection" signal for the tapping spindle before performing the synchronous tapping command.

M01 No spindle serial connection 0054

Details

Synchronous tapping command was issued in the multiple-spindle control II, while the spindle with the "spindle selection" signal ON was not serially connected.

Remedy

- Make sure the "spindle selection" signal for the spindle is ON.
- Consider the machine construction when issuing the command.

M01 Spindle fwd/rvs run para err 0055

Details

Asynchronous tapping command was issued when M code of the spindle forward/reverse run command, set by "#3028 sprcmm", was one of the followings in the multiple-spindle control II.

- M0, M1, M2, M30, M98, M99, or M198
- M code No. that commands to enable/disable the "macro interrupt" signal

Remedy

- Correct the "#3028 sprcmm (Tap cycle spindle forward run/reverse run M command)" setting.

M01 Tap pitch/thread number error 0056

Details

The command for the pitch or the number of threads is not correct in the synchronous tapping command of the multiple-spindle control II.
 The pitch is too small for the spindle rotation speed.
 Thread number is too large for the spindle rotation speed.

Remedy

- Correct the pitch, number of threads or rotation speed of the tapping spindle.

M01 Wait for tap retract 0057

Details

The axis travel command is interlocked in the part system where the "Tap retract possible" signal is ON.

Remedy

- If tap retract is necessary, perform it before issuing an axis travel command. However, tapping retract is not allowed during automatic operation. Carry out tapping retract after resetting.
- If tap retract is not necessary, cancel the tap retract enabled state.

M01 Handle ratio too large 0060

Details

- The handle ratio is too large for the handle feed clamp speed.
 (The handle feed clamp speed changes according to the rapid traverse rate, external feedrate, maximum speed outside the soft limit range and etc. (or external deceleration speed when external deceleration is valid))

Remedy

- Change the settings of the handle feed clamp speed or the handle ratio.

M01 R-pos offset value illegal 0065

Details

At the start of reference position initial setting, "#2034 rfpofs (Distance-coded reference position detection offset) is not set to "0".

Remedy

- Set "#2034 rfpofs" to "0", then turn the power ON again to perform the reference position initial setting.

M01 R-pos scan distance exceeded 0066

Details

Reference position could not be established within the maximum scan distance.

Remedy

- Check the scale to see if it has dirt or damage.
- Check if the servo drive unit supports this function.

M01 Illegal op in wk instl err cmp 0070

Details

One of the following operations was attempted during workpiece installation error compensation.

- Manual interruption
- Automatic operation handle interruption
- MDI interruption
- PLC interruption

Remedy

- Return the operation mode to the original mode to remove the cause.

M01 No operation mode 0101

Details

No operation mode

Remedy

- Check for any broken wires in the input mode signal line.
- Check for any failure of the MODE SELECT switch.
- Correct the sequence program.

M01 Cutting override zero 0102

Details

The "cutting feed override" switch on the machine operation panel is set to "0".
The override was set to "0" during a single block stop.

Remedy

- Set the "cutting feed override" switch to a value other than "0" to clear the error.
- If the "cutting feed override" switch has been set to a value other than "0", check for any short circuit in the signal line.
- Correct the sequence program.

M01 External feed rate zero 0103

Details

MANUAL FEEDRATE switch on the machine operation panel is set to "0" when the machine is in the JOG or automatic dry run mode.
"Manual feedrate B" is set to "0" during the JOG mode when manual feedrate B is valid.
"Each axis manual feedrate B" is set to "0" during the JOG mode when each axis manual feedrate B is valid.

Remedy

- Set the MANUAL FEEDRATE switch to a value other than "0" to release the error.
- If the MANUAL FEEDRATE switch has been set to a value other than "0" check for any short circuit in the signal line.
- Correct the sequence program.

M01 F 1-digit feed rate zero 0104

Details

The F1-digit feedrate has been set to "0" when the F1-digit feed command was executed.

Remedy

- Set the F1-digit feedrate (from "#1185 spd_F1 (F1 digit feedrate F1)" to "#1189 spd_F5 (F1 digit feedrate F5)").

M01 Spindle stop 0105

Details

The spindle stopped during the synchronous feed/thread cutting command.

Remedy

- Rotate the spindle.
- If the workpiece is not being cut, start dry run.
- Check for any broken wire in the spindle encoder cable.
- Check the connections for the spindle encoder connectors.
- Check the spindle encoder pulse.
- Correct the program. (commands and addresses)

M01 Handle feed ax No. illegal 0106

Details

The axis, designated at handle feed, is out of specifications.
No axis has been selected for handle feed.

Remedy

- Check for any broken wires in the handle feed axis selection signal line.
- Correct the sequence program.
- Check the number of axes in the specifications.

M01 Spindle rotation speed over 0107

Details

Spindle rotation speed exceeded the axis clamp speed during the thread cutting command.

Remedy

- Lower the commanded rotation speed.

M01 Fixed pnt mode feed ax illegal 0108**Details**

The axis, designated in the manual arbitrary feed, is out of specifications.
The feedrate in manual arbitrary feed mode is illegal.

Remedy

- Check for any broken wires in the axis selection signal line or the feedrate line for the manual arbitrary feed mode.
- Check the specifications for the manual arbitrary feed mode.

M01 Block start interlock 0109**Details**

An interlock signal has been input to lock the block start.

Remedy

- Correct the sequence program.

M01 Cutting block start interlock 0110**Details**

An interlock signal has been input to lock the cutting block start.

Remedy

- Correct the sequence program.

M01 Restart switch ON 0111**Details**

Restart switch has been turned ON and manual mode has been selected before the restart search is completed.

Remedy

- Search the block to restart.
- Turn the restart switch OFF.

M01 Program check mode 0112**Details**

The automatic start button was pressed during program check or in program check mode.

Remedy

- Press the reset button to cancel the program check mode.

M01 Auto start in buffer correct 0113**Details**

The automatic start button was pressed during buffer correction.

Remedy

- Press the automatic start button after the buffer correction is completed.

M01 In reset process 0115**Details**

The automatic start button was pressed during resetting or tape rewinding.

Remedy

- When rewinding the tape, wait for the winding to end, or press the reset button to stop the winding, and then press the automatic start button.
- During resetting, wait for the resetting to end, and then press the automatic start button.

M01 Playback not possible 0117**Details**

The playback switch was turned ON during editing.

Remedy

- Cancel the editing by pressing the input or previous screen key before turning ON the playback switch.

M01 Turn stop in normal line cntrl 0118

Details

The turning angle at the block joint exceeded the limit during normal line control.

In normal line control type I:

"#1523 C_feed (Normal line control axis turning speed)" has not been set.

In normal line control type II:

When turning in the inside of the arc, the set value for "#8041 C-rot. R" is larger than the arc radius.

Remedy

- Correct the program.
- Correct the "#1523 C_feed (Normal line control axis turning speed)" setting.
- Correct the "#8041 C rot. R" setting.

M01 Reverse run impossible 0119

Details

Either of the following conditions occurred:

- there is no block to run backward.
- eight blocks has been continued without any travel command.

Remedy

- Execute forward run to clear the alarm.
- Reset to clear the alarm.

M01 In synchronous correction mode 0120

Details

The synchronous correction mode switch was pressed in non-handle mode.

Remedy

- Select the handle or manual arbitrary feed mode.
- Turn OFF the correction mode switch.

M01 No synchronous control option 0121

Details

The synchronous control operation method was set (with R2589) while no synchronous control option was provided.

Remedy

- Set "0" for "synchronous control operation method".

M01 Computer link B not possible 0123

Details

Cycle start was attempted before resetting was completed.

Computer link B operation was attempted at the 2nd or further part system in a multi-part system.

Remedy

- Perform the cycle start after resetting has been completed.
- Set "#8109 HOST LINK" to "0" and then set to "1" before performing the cycle start.
- Computer link B operation cannot be performed at the 2nd or further part system in a multi-part system.

M01 X/Z axes simultaneous prohibit 0124

Details

The basic axis corresponding to the inclined axis was started simultaneously in the manual mode while the inclined axis control was valid.

Remedy

- Turn the inclined axis and basic axis start OFF for both axes. (This is also applied for manual/automatic simultaneous start.)
- Disable the basic axis compensation, or command it to axes one by one.

M01 Rapid override zero 0125

Details

The RAPID TRAVERSE OVERRIDE switch on the machine operation panel is set to "0".

Remedy

- Set the RAPID TRAVERSE OVERRIDE switch to a value other than "0" to clear the error.
- If the RAPID TRAVERSE OVERRIDE switch has been set to a value other than "0", check for any short circuit in the signal line.
- Correct the sequence program.

M01 Program restart machine lock 0126

Details

Machine lock was applied on the return axis being manually returned to the restart position.

Remedy

- Cancel the machine lock and resume the operation.

M01 Rot axis parameter error 0127

Details

Orthogonal coordinate axis name does not exist.

Rotary axis name does not exist.

A duplicate name is used for the designated orthogonal coordinate axis.

The number of axes that were selected to change tool length compensation along the tool axis amount exceeds the maximum number of axes.

The designated orthogonal coordinate axis name is the same as the rotary axis name.

Remedy

- Correct the rotary axis configuration parameters.

M01 Restart pos return incomplete 0128

Details

Automatic return was performed with an axis whose return to the restart position was not complete.

Remedy

- Perform restart position return manually.
- Enable "#1302 AutoRP (Automatic return by program restart)" before executing the automatic start.

M01 PLC interruption impossible 0129

Details

After the automatic startup, the "PLC interrupt" signal was turned ON during buffer correction, program restart, arbitrary reverse run, tool retract and return, high-speed high-accuracy control II, NURBS interpolation or single block stop at the middle point of G28/G29/G30.

Remedy

- By turning OFF the "PLC interrupt" signal, or by resetting the NC the error can be cancelled.

M01 Restart posn return disabled 0130

Details

Restart position return was attempted in a mode where the return is disabled.

Remedy

- Correct the program restart position.

M01 Zero point return interruption 0131

Details

Compound type fixed cycle program was interrupted with manual zero point return, and cycle start was carried out without carrying out reset.

Remedy

- Cancel the program execution by reset.

M01 Chopping override zero 0150

Details

The override became "0" in the chopping operation.

Remedy

- Correct the setting of "chopping override" (R2503).
- Correct the setting of "rapid traverse override" (R2502).

M01 Command axis chopping axis 0151

Details

A chopping axis movement command was issued from the program during the chopping mode. (This alarm will not occur for the command with the movement amount "0".)
(All axes interlock state will be applied.)

Remedy

- Press the reset button or turn OFF the "chopping" signal. When the "chopping" signal is turned OFF, the axis returns to the reference position and performs the movement command in the program.

M01 Bottom dead center pos. zero 0153

Details

The bottom dead center position is set to the same position as the upper dead center position.

Remedy

- Correct the bottom dead center position.

M01 Chopping disable for handle ax 0154

Details

Chopping has been attempted while the chopping axis is selected as the handle axis.

Remedy

- Select an axis other than the chopping axis as the handle axis, or start chopping after changing the mode to the other mode.

M01 Dir cmd mode invalid 0157

Details

- The drive unit's software or hardware does not conform to the direct command mode.
- Inclined axis control is active.
- Control axis synchronization across part system is active.
- Control axis superimposition was activated during direct command mode.

Remedy

- The software or hardware does not conform to the function. Contact service center.
- Turn the inclined axis control valid signal OFF.
- Turn the synchronous control request signal OFF.
- Turn the superimposition control request signal OFF.

M01 Dir cmd mode restart invalid 0158

Details

- Automatic start was carried out without reset after the retract in direct command mode.

Remedy

- Finish the machining for now by resetting the NC.

M01 No speed set out of soft limit 0160

Details

The axis, without any maximum speed outside of the soft limit range set, was returned from the outside of the soft limit range.

Remedy

- Correct the "#2021 out_f (Maximum speed outside soft limit range)" setting.
- Correct the soft limit range (with "#2013 OT- (Soft limit I-)" and "#2014 OT+ (Soft limit I+)").

M01 Ill. op during T tip control 0170

Details

Illegal operation was attempted during tool tip center control.

Remedy

- Change the operation mode to the previous one and restart.

M01 Illegal OP in tilted face cut 0185

Details

Any of the following illegal operations was attempted during inclined surface machining mode.

- Manual interrupt
- Handle interrupt in automatic operation
- MDI interrupt
- PLC interrupt
- Arbitrary reverse run

Remedy

- Switch the operation mode back to the previous to remove the cause of this failure.

M01 Interference check invalidated 0200

Details

The 3D machine interference check is invalidated. This alarm is output to NC alarm 5.

Remedy

- Validate all the interference check settings.
- If there is any axis which has not completed zero point return, establish the zero point first.

M01 Machine interference 1 0201

Details

It was judged that an interference occurred in the No.1 step interference check and caused a deceleration stop.

When machine interference is detected, the interfered part is highlighted (yellow/red) and the part's name is displayed on the 3D monitor's model display.

Remedy

- Move the axis in a direction which does not cause interference.
- Press RESET to cancel the alarm.
- You can move the axis in the same travel direction as before the interference.
But the axis movement is done using the 2nd step interference check distance.
(In manual operation)

M01 Machine interference 2 0202

Details

It was judged that an interference occurred in the No.2 step interference check and caused a deceleration stop.

When machine interference is detected, the interfered part is highlighted (red) and the part's name is displayed on the 3D monitor's model display.

Remedy

- Move the axis in a direction which doesn't cause interference.
- Press RESET to cancel the alarm.

M01 Multi ax for 5-ax manual feed 0230

Details

More than one axis was designated simultaneously in manual mode while the manual feed for 5-axis machining was valid.

Remedy

- Command the manual feed to each axis one by one.

M01 5-ax manual feed coord sys err 0231

Details

- More than one of the three bits for selecting hypothetical coordinate system was turned ON.
- Hypothetical coordinate system was selected while the manual feed for 5-axis machining was invalidated by the parameter setting.

Remedy

- Check the sequence program.
- Validate the manual feed for 5-axis machining (parameter "#7912 NO_MANUAL").

M01 Illegal op in 5 ax tool R comp 0232

Details

An illegal operation (such as manual interrupt) was attempted during tool radius compensation for 5-axis machining.

Remedy

- Operations such as manual interrupt are disabled while the tool radius compensation for 5-axis machining is being performed.

M01 Machining surface operation disabled 0250

Details

Machining surface operation (selection, indexing or cancel) was attempted while the operation is disabled.

Remedy

- Cancel the other modes so that the inclined surface machining command (G68.2), tool axis direction control (G53.1) and the inclined surface machining cancel command (G69) can be issued.
- Wait until the axes stop completely (until the smoothing for all axes reaches zero).
- Perform operation search for machining programs.

M01 Axs travel n/a in manual index 0251

Details

Moving a rotary axis was attempted during manual machining surface indexing, when a manual operation mode other than handle mode was selected.

Remedy

- Change the operation mode to a handle mode before carrying out the manual surface indexing.

M01 Tool length compensation amt 0 0252

Details

The tool length compensation amount for performing the R-Navi indexing type 2 is 0.

Remedy

- Set the tool length compensation amount for performing the indexing type 2 to a value other than 0.

M01 Feat coord ill w/ multi-handle 0253

Details

Manual feed feature coordinate system was selected while two or more handles were ON.

Remedy

- Manual feed on a feature coordinate system is disabled while two or more handles are enabled (*).
 - Press [Manual coord] and select the machine coordinate system.
 - Reduce the number of enabled handles (*) to one.
- (*) An enabled handle means the handle for which "Nth handle valid" signal (HSnS) is ON.

M01 Auto backlash adjust illegal 0270

Details

- A measurement condition adjustment or backlash adjustment was attempted to an axis with which automatic backlash adjustment is impossible.
- A measurement condition adjustment or backlash adjustment was attempted even though all the axes had not reached the 1st reference position.
- The operation mode is other than memory mode.
- The slave axis of synchronous control is selected as adjustment axis.
- An attempt has been made to start an adjustment by cycle start.

Remedy

- Check the adjustment axis.
- Start the adjustment after all the axes return to the 1st reference position.
- Check the operation mode.
- Select the master axis of synchronous control as adjustment axis when adjusting the slave axis.
- Start the adjustment by automatic backlash adjustment start signal.

M01 Operating auto backlash adjust 0271

Details

An illegal operation was attempted during measurement condition adjustment or backlash adjustment.

Remedy

- Continue the operation after canceling the measurement condition adjustment and backlash adjustment.

M01 APLC password mismatch 0280

Details

The APLC authentication password is inconsistent.

Remedy

- Contact the machine tool builder.

M01 High-cycle sampling disabled 0290

Details

- The drive unit's hardware or software does not conform to the high-cycle sampling mode.
- High-cycle data are not used even when high-cycle sampling has been set.
- High-cycle sampling was attempted while the axis targeted for high-cycle sampling was moving.
- High-cycle sampling was attempted during speed monitor mode.
- High-cycle sampling was attempted while any of the following operations is being executed: Dog-type zero point return, absolute position setting, synchronous tapping, spindle synchronization, hobbing, tool spindle synchronization IC.

Remedy

- The software or hardware does not conform to the function. Contact service center.
- Set data for high-cycle sampling.
- Execute high-cycle sampling after stopping the axis targeted for high-cycle sampling.
- Execute high-cycle sampling after cancelling the speed monitor mode.
- Execute high-cycle sampling after stopping the currently executed functions.

M01 N/A during high-cycle sampling 0291

Details

- An attempt to activate "Speed monitor mode" was made during the high-cycle sampling mode.
- An attempt to change the gear signal was made during the high-cycle sampling mode.
- An attempt to execute spindle orientation was made during the high-cycle sampling mode.
- Spindle detach was attempted during the high-cycle sampling mode.
- Any of the following operations was attempted during the high-cycle sampling mode: Dog-type zero point return, absolute position setting, spindle/C axis changeover, synchronous tapping, spindle synchronization, hobbing, or tool spindle synchronization IC.

Remedy

- Change the speed monitor mode signal back, finish high-cycle sampling, and then select the speed monitor mode.
- Change the gear signal back, finish high-cycle sampling, and then change the gear.
- Change the spindle orientation signal back, finish high-cycle sampling, and then execute orientation.
- Change the spindle detach signal back, finish high-cycle sampling, and then carry out spindle detachment.
- Execute the operation after terminating high-cycle sampling.

M01 Illegal movement command during superimposition 1003

Details

- A machine command was issued to the superimposing axis.
- Reference position return was attempted on the superimposing axis.
- Skip command was issued to the master or superimposing axis.
- Dog-type reference position return was attempted on the master axis.

Remedy

- Correct the program.

M01 Superimposition command illegal 1004

Details

- Superimposition start command was issued to the axis which is executing the following functions.
Synchronization control
Milling interpolation
- Superimposition start command was issued to the axis which was under superimposition control.
- The superimposition command was issued to an axis that belongs to the same part system as a basic or synchronous axis of synchronization across part systems.

Remedy

- Correct the program.

M01 G114.n command illegal 1005

Details

G114.n has been commanded during the execution of G114.n.
G51.2 has been commanded when G51.2 spindle-spindle polygon machining mode has been already entered at another part system.

Remedy

- Command G113 to cancel the operation.
- Turn ON the "spindle synchronization cancel" signal to cancel the operation.
- Command G50.2 to cancel the operation.
- Turn ON the "spindle-spindle polygon cancel" signal to cancel the operation.

M01 Spindle in-use by synchro tap 1007

Details

The spindle is being used in synchronized tapping.

Remedy

- Cancel the synchronized tapping.

M01 GB spindle synchro signal OFF 1014**Details**

- A forward run, reverse run, orientation, synchronous tapping, spindle synchronization, tool spindle synchronization I, tool spindle synchronization II or C-axis servo ON command was issued to the reference spindle while the guide bushing spindle synchronization signal was OFF.
- The guide bushing spindle synchronization signal was turned OFF during a forward run, reverse run, orientation, synchronous tapping, spindle synchronization, tool spindle synchronization I, tool spindle synchronization II or C-axis servo ON command.

Remedy

- Check the ladder program.

Details

- Orientation was commanded during the "guide bushing spindle synchronization" signal ON with spindle zero point detection with contactless switch and turret indexing enabled.
- C axis servo ON was commanded during the "guide bushing spindle synchronization" signal ON with spindle C axis parameter change enabled.

Remedy

- Check the parameters.

M01 GB SP sync:Spindle type error 1015**Details**

- A spindle drive unit other than the drive unit after MDS-D series or analog spindle is used for the master spindle or guide bushing spindle.

Remedy

- Check the parameters.
- Change the reference spindle or guide bushing spindle to a spindle that is drive unit after MDS-D series.

M01 GB SP sync:Phase mem sgnl ilgl 1021**Details**

- The guide bushing spindle synchronization phase memory signal was turned ON while the master spindle or guide bushing spindle was rotating.
- The guide bushing spindle synchronization phase memory signal was turned ON while the guide bushing spindle synchronization signal was OFF.

Remedy

- Check the ladder program.

M01 GB SP sync:Phase set sgnl ilgl 1022**Details**

- The guide bushing spindle synchronization phase alignment signal was turned ON while the master spindle or guide bushing spindle was stopped.

Remedy

- Check the ladder program.

M01 GB SP sync:Z phase not pass 1023**Details**

- When the guide bushing spindle synchronization phase memory signal was ON, the master spindle or guide bushing spindle's Z-phase was not passed.

Remedy

- Check the ladder program.

M01 SP-C ax ctrl runs independtly 1026**Details**

- C axis mode command has been issued for polygon machining spindle.
- C axis mode command has been issued for synchronized tapping spindle.
- Polygon command has been issued for synchronized tapping spindle.
- Spindle is being used as spindle/C axis.

Remedy

- Cancel the C axis command.
- Cancel the polygon machining command.
- Cancel the C axis with servo OFF.

M01 Synchronization mismatch 1030

Details

Different M codes were each commanded as synchronization M code in each of the two part systems. Synchronization with the "!" code was commanded in another part system during M code synchronization.
Synchronization with the M code was commanded in another part system during synchronization with the "!" code.

Remedy

- Correct the program so that the M codes match.
- Correct the program so that the same synchronization codes are commanded.

M01 Multiple C axes select invalid 1031

Details

The "C axis selection" signal has been changed when the multiple C axes selection is not available. The selected axis by the "C axis selection" signal cannot be controlled for the multiple C axes selection.

Remedy

- Correct the parameter settings and program.

M01 Tap retract Sp select illegal 1032

Details

Tap retract has been executed with a different spindle selected. Cutting feed is in wait state until synchronization is completed.

Remedy

- Select the spindle for which tap cycle was halted before turning ON the "tap retract" signal.

M01 Sp-Sp polygon cut interlock 1033

Details

Cutting feed is in wait state until synchronization is completed.

Remedy

- Wait for the synchronization to end.

M01 Mixed sync ctrl prmtr illegal 1034

Details

There is a mistake in the settings of mixed control axis parameters (crsax [1] to [8]). Mixed control was attempted within one and the same part system. Any of the parameter settings is disabling mixed control.

Remedy

- Correct the parameter settings for the mixed control (cross axis control).

M01 Mixed sync ctrl disable modal 1035**Details**

Mixed control (cross axis control) was commanded for a part system in which the mixed control (cross axis control) is disabled as shown below.

- During nose R compensation mode
- During pole coordinate interpolation mode
- During cylindrical interpolation mode
- During balance cut mode
- During fixed cycle machining mode
- During facing turret mirror image
- During constant surface speed control mode
- During hobbing mode
- During axis name switch

An axis was transferred to another part system, and mixed control was attempted with the part system's maximum number of control axes exceeded.

An axis was removed from the part system, and mixed control was attempted with the part system's number of axes zero.

Another axis exchange was attempted to the axis which was already transferred to another part system for mixed control.

Mixed control was attempted with an axis of a part system not in automatic operation.

Remedy

- Correct the program.

M01 Synchro ctrl setting disable 1036**Details**

"Synchronous control operation method" was set (with R2589) when the mode was not the C axis mode.

"Synchronous control operation method" was set (with R2589) in the zero point not set state.

Mirror image is disabled.

External mirror image or parameter mirror image was commanded during facing turret mirror image.

Remedy

- Set the contents of the R2589 register to "0".
- Correct the program and parameters.

M01 Synchro start/cancel disable 1037**Details**

Synchronous control start/cancel command was issued when the start/cancel is disabled.

Remedy

- Correct the program and parameters.

M01 Move cmdn invld to synchro ax 1038**Details**

A travel command was issued to a synchronous axis in synchronous control.

Remedy

- Correct the program.

M01 No spindle speed clamp 1043**Details**

The constant surface speed command (G96) was issued to the spindle which is not selected for the spindle speed clamp command (G92/G50) under Multiple spindle control II.

Remedy

Press the reset key and carry out the remedy below.

- Select the spindle before commanding G92/G50.

M01 Cont ax superimpos II prm illg 1044

内容

- There is a mistake in the setting of the superimposition control base axis parameter (#2089 bsax_pl).
- Superimposition control is not available under the current parameter settings.

処置

- Correct the parameter.

M01 Sp synchro phase calc illegal 1106

Details

Spindle synchronization phase alignment command was issued while the "phase shift calculation request" signal was ON.

Remedy

- Correct the program.
- Correct the sequence program.

M01 GB SP sync:Cancel sgnl illegal 1137

Details

The guide bushing spindle synchronization temporary cancel signal was turned ON/OFF when the master spindle and G/B spindle were in one of the following modes.

- During rotation (when not stopped)
- During tap cycle synchronization mode
- During spindle synchronization mode
- During tool-spindle synchronization I (polygon machining) mode
- During tool-spindle synchronization II (hobbing) mode
- During spindle C axis control C axis mode
- During orientation/indexing

Remedy

- Check the ladder program.

M01 GB SP sync runs independently 1138

Details

- The reference spindle was commanded as a spindle related to tool spindle synchronization IC (polygon).
- The guide bushing spindle was commanded as a synchronous tapping spindle.
- The guide bushing spindle was commanded as a spindle related to spindle synchronization/tool spindle synchronization I (polygon)/tool spindle synchronization II (hobbing).

Remedy

- Check the program.

M80 POSITION ERROR

Details

An axis position is illegal.

An alarm is displayed (AL4 is output) and a block stop is applied on the machining program.

When the block stop is not allowed in the thread cutting cycle and the like, the stop is applied at the next position where allowed.

Remedy

Carry out reset. Then confirm that the system starts the operation. If the alarm is displayed again, turn ON the emergency stop switch and turn the NC power OFF and ON.

M90 Parameter set mode

Details

The lock for setup parameters has been released. Setting the setup parameters is enabled while automatic start is disabled.

Remedy

Refer to the manual issued by the machine tool builder.

M91 INVALID MEASUR. 0002

Details

Data is over the range
The measurement result exceeds the tool data setting range.

Remedy

Correct the settings of "#2015 tlm- (Negative direction sensor of tool setter)" and "#2016 tlm+ (Positive direction sensor of tool setter or TLM standard length)".

M91 INVALID MEASUR. 0003

Details

No corresponding No.
No measurement tool No. has been set.
The registered No. is out of the specifications.

Remedy

Correct the measurement tool No.

M91 INVALID MEASUR. 0045

Details

Measurement axis illegal
Sensor has been turned ON while two or more axes are moving.

Remedy

Move a single axis when the sensor is contacted.

M91 INVALID MEASUR. 0046

Details

Measurement axis has not returned to reference position
Reference position return has not been executed on a measurement axis in an incremental system.

Remedy

Carry out the reference position return on the measurement axis before measuring the tool.

M91 INVALID MEASUR. 0089

Details

Sensor signal illegal ON
Sensor has already been ON when TLM mode is turned ON. The travel amount was so small that the tool contacted the sensor.

Remedy

All axes are interlocked when this alarm has occurred.
Turn the TLM mode OFF or use the interlock cancel signal to move the tool off the sensor.
Ensure at least 0.1mm for the movement to the sensor.

M91 INVALID MEASUR. 9000

Details

Speed at contact is below minimum
The tool has contacted the sensor at the lower speed than set in "#1508 TLM_Fmin (Minimum speed toward tool setter)".

Remedy

Correct the feed rate to move the tool to the sensor.

M91 INVALID MEASUR. 9001

Details

Speed at contact is over maximum
The tool has contacted the sensor at the higher speed than set in "#1509 TLM_Fmax (Maximum speed toward tool setter)".

Remedy

Correct the feed rate to move the tool to the sensor.

M91 INVALID MEASUR. 9002

Details

Change of compensation No. or sub-side selection during measurement
A compensation No. or sub-side valid signal state has been changed while a sensor signal is ON or a compensation amount is being written.

Remedy

Carry out the measurement again.

M91 INVALID MEASUR. 9003

Details

Error on response timing of sensor signal
A compensation No. has been changed at the same time as a sensor's response.

Remedy

Carry out the measurement again.

M92 IGNORE INT.LOCK

Details

Manual tool length measurement Interlock temporarily canceled
"M01 Operation error 0005" and "M01 Operation error 0019", which occur at manual tool length measurement, are temporarily canceled. When a tool has contacted a sensor and "M01 Operation error 0019" has occurred, tool escape is enabled by temporarily turning ON the interlock cancel request. This alarm notifies that the interlock is disabled in the meantime.

Remedy

After carrying out the tool escape from the sensor, turn OFF the interlock temporary cancel signal for manual tool length measurement.

Appendix 6.2 Stop Codes (T)

T01 Axis in motion 0101

Details

Automatic start is not possible as one of the axes is moving.

Remedy

- Try automatic start again after all axes have stopped.

T01 NC not ready 0102

Details

Automatic start is not possible as the NC is not ready.

Remedy

- Another alarm has occurred. Check the details and remedy.

T01 Reset signal ON 0103

Details

Automatic start is not possible as the "reset" signal has been input.

Remedy

- Turn OFF the "reset" signal.
- Check for any failure of the reset switch which has caused the switch's continuous ON.
- Correct the sequence program.

T01 Auto operation pause signal ON 0104

Details

The feed hold switch on the machine operation panel is ON (valid).

Remedy

- Correct the feed hold switch setting.
- The feed hold switch is B contact switch.
- Fix any broken wires in the feed hold signal line.
- Correct the sequence program.

T01 H/W stroke end axis exists 0105

Details

Automatic start is not possible as one of the axes is at the stroke end.

Remedy

- Manually move any axis whose end is at the stroke end.
- Check for any broken wires in the stroke end signal line.
- Check for any failure in the stroke end limit switch.

T01 S/W stroke end axis exists 0106

Details

Automatic start is not possible as one of the axes is at the stored stroke limit.

Remedy

- Move the axis manually.
- If the axis's end is not at the stroke end, check the parameters.

T01 No operation mode 0107

Details

The operation mode has not been selected.

Remedy

- Select automatic operation mode.
- Check for any broken wires in the signal line for automatic operation mode (memory, tape, MDI).

T01 Operation mode duplicated 0108

Details

Two or more automatic operation modes have been selected.

Remedy

- Check for any short circuit in the mode (memory, tape, MDI) selection signal line.
- Check for any failure in the switch.
- Correct the sequence program.

T01 Operation mode changed 0109

Details

The automatic operation mode has changed to another automatic operation mode.

Remedy

- Return to the original automatic operation mode, and execute automatic start.

T01 Tape search execution 0110

Details

Automatic start is not possible as tape search is being executed.

Remedy

- Wait for the tape search to be completed and then execute the automatic start.

T01 Cycle start prohibit 0111

Details

Automatic start is disabled because restart search is in execution.

Remedy

- Execute automatic start after the restart search is completed.

T01 CNC overheat 0113

Details

Automatic start is not possible because a thermal alarm (Z53 CNC overheat) has occurred.

Remedy

- Temperature of the control unit has exceeded the specified temperature.
- Take appropriate measures to cool the unit.

T01 Cycle st. prohibit(Host comm.) 0115

Details

Automatic start cannot is not possible because the NC is communicating with the host computer.

Remedy

- Wait for the communication with host computer to be ended and then execute the automatic start.

T01 Cycle st prohibit(Battery alm) 0116

Details

Automatic start is not possible because the voltage of the battery in the NC control unit has dropped.

Remedy

- Replace the battery of the NC control unit.
- Contact the service center.

T01 R-pnt offset value not set 0117

Details

Automatic operation is not possible because no reference position offset value has been set.

Remedy

- Perform the reference position initialization setting, then set "#2034 rfpofs(Distance-coded reference position detection offset)".

T01 Cycle start prohibit 0118**Details**

Tool retract position signal OFF
The axis was moved from the tool retract position. Tool retract position reached signal is OFF.

Remedy

Once the axis has been moved off the tool retract position, resuming the program is not possible.
Cancel the program by reset and then execute it from the start.

T01 In absolute position alarm 0138**Details**

A start signal was input during an absolute position detection alarm.

Remedy

- Clear the absolute position detection alarm, and then input the start signal.

T01 In abs posn initial setting 0139**Details**

A start signal was input during zero point initialization in the absolute position detection system.

Remedy

- Complete zero point initialization before inputting the start signal.

T01 Start during MDI operation at other part system disable 0141**Details**

In multi-part system, a start signal was input for MDI mode while the MDI operation was being carried out in another part system.

Remedy

- End the other part system's operation before starting.

T01 Cycle start prohibit 0142**Details**

In manual coordinate system setting
Automatic start is not allowed during the manual coordinate system setting.

Remedy

The system restarts after either of the manual coordinate system setting completion signal or the error end signal has been turned ON.

T01 In manual measurement 0143**Details**

Automatic start is disabled because manual measurement is in execution.

Remedy

- Execute automatic start after the manual measurement is completed.

T01 APLC password mismatch 0160**Details**

The APLC authentication password is inconsistent.

Remedy

- Contact the machine tool builder.

T01 Cycle start prohibit 0180**Details**

Automatic start became disabled while servo auto turning is enabled.

Remedy

- Set "#1164 ATS" to "0" when the servo auto turning is not executed.

T01 Cycle start prohibit 0190**Details**

Automatic start is not possible because the setting of setup parameters is enabled.

Remedy

- Refer to the manual issued by the machine tool builder.

T01 Cycle start prohibit 0191

Details

Automatic start was attempted while a file was being deleted/written.

Remedy

- Wait for the file to be deleted/written and then execute the automatic start.

T01 Cycle st. prohibit (Term exp'd) 0193

Details

Automatic start is not possible because the valid term has been expired.

Remedy

- Obtain a decryption code from the machine tool builder and input it in the NC, then turn the power ON again.

T02 H/W stroke end axis exists 0201

Details

An axis is at the stroke end.

Remedy

- Manually move the axis away from the stroke end limit switch.
- Correct the machining program.

T02 S/W stroke end axis exists 0202

Details

An axis is at the stored stroke limit.

Remedy

- Manually move the axis.
- Correct the machining program.

T02 Reset signal ON 0203

Details

The reset has been entered.

Remedy

- The program execution position has returned to the start of the program. Execute automatic operation from the start of the machining program.

T02 Auto operation pause signal ON 0204

Details

The "feed hold" switch is ON.

Remedy

- Press the CYCLE START switch to resume the automatic operation.

T02 Operation mode changed 0205

Details

The operation mode has changed to another mode during automatic operation.

Remedy

- Return to the original automatic operation mode, and press the CYCLE START switch to resume the automatic operation.

T02 Acc/dec time cnst too large 0206

Details

The acceleration and deceleration time constants are too large. (This alarm occurs with the system alarm Z59.)

Remedy

- Set a larger value for "#1206 G1bF(Maximum speed)".
- Set a smaller value for "#1207 G1btL(Time constant)".
- Set a lower cutting speed.

T02 Abs posn detect alarm occurred 0215**Details**

An absolute position detection alarm occurred.

Remedy

- Clear the absolute position detection alarm.

T02 Aux axis changeover error 0220**Details**

A travel command was issued to an auxiliary axis.

Remedy

- Turn ON the "NC axis control selection" signal and press the CYCLE START switch to restart the automatic operation with.

T03 Single block stop signal ON 0301**Details**

The SINGLE BLOCK switch on the machine operation panel is ON.
The SINGLE BLOCK or MACHINE LOCK switch changed.

Remedy

- Press the CYCLE START switch to resume the automatic operation.

T03 Block stop cmnd in user macro 0302**Details**

A block stop command was issued in the user macro program.

Remedy

- Press the CYCLE START switch to resume the automatic operation.

T03 Operation mode changed 0303**Details**

Automatic mode changed to another automatic mode.

Remedy

- Return to the original automatic operation mode, and press the CYCLE START switch to resume the automatic operation.

T03 MDI completed 0304**Details**

MDI operation has ended the last block.

Remedy

- Set the MDI operation again, and press the CYCLE START switch to start the MDI operation.

T03 Block start interlock 0305**Details**

The interlock signal, which locks the block start, is ON.

Remedy

- Correct the sequence program.

T03 Cutting blk start interlock 0306**Details**

The interlock signal, which locks the block cutting start, is ON.

Remedy

- Correct the sequence program.

T03 Inclined Z offset change 0310**Details**

The "inclined axis control: No Z axis compensation" signal has turned ON or OFF during the program operation.

Remedy

- Press the CYCLE START switch to resume the automatic operation.

T03 Aux axis changeover error 0330

Details

The "NC axis control selection" signal was turned OFF while a NC axis was traveling.

Remedy

- Turn the "NC axis control selection" signal ON and press the CYCLE START switch to resume the automatic operation.

T04 Collation stop 0401

Details

Collation stop occurred.

Remedy

- Execute the automatic start to resume the automatic operation.

T10 Fin wait (Factors for waiting completion)

Details

The following Nos. are shown during the operation of the corresponding completion wait factor. The numbers will disappear when the operation is completed. The completion wait factor is indicated with four digits (in hexadecimal).

Display format of completion wait factor

0 _ _ _
(a)(b)(c)

Each of the hexadecimal numbers (a), (b) and (c) indicates the following details.

(a)

bit0: In dwell execution
bit3: Unclamp signal wait (Note 1)

(b)

bit0: Waiting for spindle position to be looped
bit3: Door open (Note 2)

(c)

bit0: Waiting for MSTB completion
bit1: Waiting for rapid traverse deceleration
bit2: Waiting for cutting speed deceleration
bit3: Waiting for spindle orientation completion

(Note 1) This shows the wait state for the unclamp signal's ON/OFF for the index table indexing.

(Note 2) This shows the door open state caused by the door interlock function.

T11 Fin wait 0010 (Factors for waiting completion)

Details

The following Nos. are shown during the operation of the corresponding completion wait factor. The numbers will disappear when the operation is completed. The completion wait factor is indicated with four digits (in hexadecimal).

Display format of completion wait factor

0 _ _ _
(a)(b)(c)

Each of the hexadecimal numbers (a), (b) and (c) indicates the following details.

bit0: Operation alarm display being postponed

Remedy

The parameter "#1342 AlmDly" may be able to postpone displaying a part of an operation alarm, depending on the setting.

This stop code will remain displayed while any alarm is being postponed.

And it will disappear if the postponed alarm is displayed or canceled.

Appendix 6.3 Servo/Spindle Alarms (S)

Appendix 6.3.1 Servo Errors (S01/S03/S04)

Servo alarm is displayed in the following format.

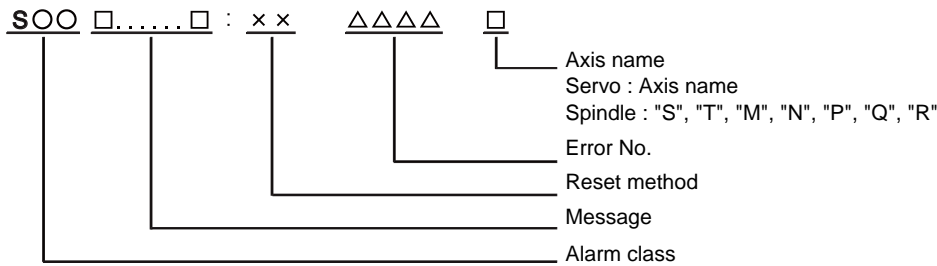

Alarm class	Message	Reset method	Resetting methods
S01	Servo alarm	PR	After removing the cause of the alarm, reset the alarm by turning the NC power ON again.
S03	Servo alarm	NR	After removing the cause of the alarm, reset the alarm by inputting the NC RESET key.
S04	Servo alarm	AR	After removing the cause of the alarm, reset the alarm by turning the drive unit power ON again.

Error No. consists of four digits (0010 to). Servo alarms are explained in ascending order of the error No. The four digits on the left part of each alarm indicate the error No.

(Note) For the details of servo alarms, refer to your drive unit's instruction manual.

Drive unit alarms

0010 Insufficient voltage

Details

- A drop of bus voltage was detected in main circuit.
- Servo stop method: Dynamic stop
- Spindle stop method: Coast to a stop

0011 Axis selection error

Details

- The axis selection rotary switch has been incorrectly set.
- Servo stop method: Initial error
- Spindle stop method: Initial error

0012 Memory error 1

Details

- A hardware error was detected during the power ON self-check.
- Servo stop method: Initial error
- Spindle stop method: Initial error

0013 Software processing error 1

Details

- An error was detected for the software execution state.
- Servo stop method: Dynamic stop
- Spindle stop method: Coast to a stop

0014 Software processing error 2

Details

- The current processing processor does not operate correctly.
- Servo stop method: Dynamic stop
- Spindle stop method: Coast to a stop

0016 Init mag pole pos detect err

Details

In the built-in motor which uses the absolute position detector, the servo ON has been set before the magnetic pole shift amount is set.

The magnetic pole position, detected in the initial magnetic pole position detection control, is not correctly set.

- Servo stop method: Dynamic stop
- Spindle stop method: Coast to a stop

0017 A/D converter error

Details

A current feedback error was detected.

- Servo stop method: Dynamic stop
- Spindle stop method: Coast to a stop

0018 Motor side dtc: Init commu err

Details

An error was detected in the initial communication with the motor side detector.

- Servo stop method: Initial error
- Spindle stop method: Initial error

0019 Detector commu err in syn cont

Details

An error of the shared detector on the machine side was detected on the secondary axis of the speed command synchronization control.

- Servo stop method: Dynamic stop

001A Machine side dtc: Init comu er

Details

An error was detected in the initial communication with the machine side detector.

- Servo stop method: Initial error
- Spindle stop method: Initial error

001B Machine side dtc: Error 1

Details

An error was detected by the detector connected to the machine side.

The error details are different according to the detector type.

- Servo stop method: Dynamic stop
 - Spindle stop method: Coast to a stop
- [Detector alarm (Servo drive unit)]
- OSA105, OSA105ET2A, OSA166, OSA166ET2NA(MITSUBISHI) Memory alarm
 - OSA18() CPU alarm
 - MDS-B-HR() Memory error
 - MBA405W(MITSUBISHI) CPU error
 - AT343, AT543, AT545(Mitsutoyo) Initialization error
 - LC193M, LC493M, LC195M, LC495M, RCN223M, RCN227M, RCN727M, RCN827M, EIB Series(HEIDENHAIN) Initialization error
 - MPRZ Scale(MHI) Installation accuracy fault
 - SR75, SR85, SR77, SR87, RU77(Magnescale) Laser diode error
 - RL40N Series(Renishaw) Initialization error
- [Detector alarm (Spindle drive unit)]
- TS5690, TS5691(MITSUBISHI) Memory error
 - MDS-B-HR() Initialization error
 - OSA18() CPU error
 - MBE405W(MITSUBISHI) CPU error
 - EIB Series(HEIDENHAIN) Initialization error
 - MPC1 scale(MHI) Installation accuracy fault
- (Note) A driver processes all reset types of alarms as "PR". However, "AR" will be applied according to the detector.

001C Machine side dtc: Error 2

Details

An error was detected by the detector connected to the machine side.
The error details are different according to the detector type.

- Servo stop method: Dynamic stop
 - Spindle stop method: Coast to a stop
 - [Detector alarm (Servo drive unit)]
 - OSA105, OSA105ET2A, OSA166, OSA166ET2NA(MITSUBISHI) LED alarm
 - MBA405W(MITSUBISHI) Waveform error
 - AT343, AT543, AT545(Mitsutoyo) EEPROM error
 - LC193M, LC493M, LC195M, LC495M, RCN223M, RCN227M, RCN727M, RCN827M, EIB Series(HEIDENHAIN) EEPROM error
 - SR75, SR85, SR77, SR87, RU77(Magnescale) System memory error
 - [Detector alarm (Spindle drive unit)]
 - TS5690, TS5691(MITSUBISHI) Waveform error
 - MBE405W(MITSUBISHI) Waveform error
 - EIB Series(HEIDENHAIN) EEPROM error
- (Note) A driver processes all reset types of alarms as "PR". However, "AR" will be applied according to the detector.

001D Machine side dtc: Error 3

Details

An error was detected by the detector connected to the machine side.
The error details are different according to the detector type.

- Servo stop method: Dynamic stop
 - Spindle stop method: Coast to a stop
 - [Detector alarm (Servo drive unit)]
 - OSA105, OSA105ET2A, OSA166, OSA166ET2NA(MITSUBISHI) Data alarm
 - OSA18() Data alarm
 - MDS-B-HR() Data error
 - MBA405W(MITSUBISHI) Data error
 - AT343, AT543, AT545(Mitsutoyo) Photoelectric type, static capacity type data mismatch
 - LC193M, LC493M, LC195M, LC495M, RCN223M, RCN227M, RCN727M, RCN827M, EIB Series(HEIDENHAIN) Relative/ absolute position data mismatch
 - MPRZ Scale(MHI) Detection position deviance
 - SR75, SR85, SR77, SR87, RU77(Magnescale) Encoder mismatch error
 - SAM/SVAM/GAM/LAN Series (FAGOR) Absolute position detection error
 - RL40N Series (Renishaw) Absolute position data error
 - [Detector alarm (Spindle drive unit)]
 - MDS-B-HR() Data error
 - OSA18() Data error
 - MBE405W(MITSUBISHI) Data error
 - MPC1 scale(MHI) Detection position deviance
- (Note) A driver processes all reset types of alarms as "PR". However, "AR" will be applied according to the detector.

001E Machine side dtc: Error 4

Details

An error was detected by the detector connected to the machine side.
The error details are different according to the detector type.

- Servo stop method: Dynamic stop
 - Spindle stop method: Coast to a stop
 - [Detector alarm (Servo drive unit)]
 - AT343, AT543, AT545(Mitsutoyo) ROM/RAM error
 - LC193M, LC493M, LC195M, LC495M, RCN223M, RCN227M, RCN727M, RCN827M, EIB Series(HEIDENHAIN) ROM/RAM error
 - MPRZ Scale(MHI) Scale breaking
 - SAM/SVAM/GAM/LAM Series (FAGOR) H/W error
 - [Detector alarm (Spindle drive unit)]
 - MPC1 scale(MHI) Scale breaking
- (Note) A driver processes all reset types of alarms as "PR". However, "AR" will be applied according to the detector.

001F Machine side dtc: Commu error

Details

- An error was detected in the communication with the machine side detector.
- Servo stop method: Dynamic stop
 - Spindle stop method: Coast to a stop

0021 Machine side dtc: No signal

Details

- In the machine side detector, ABZ-phase feedback cannot be returned even when the motor moves.
- Servo stop method: Dynamic stop
 - Spindle stop method: Coast to a stop

0022 Detector data error

Details

- An error was detected in the feedback data from the position detector.
- Servo stop method: Dynamic stop

0023 Excessive speed error

Details

- The state that there is a difference between the actual speed and command speed continued for longer than the excessive speed deviation timer setting.
- Spindle stop method: Coast to a stop

0024 Grounding

Details

- The motor power cable is in contact with FG (Frame Ground).
- Servo stop method: Dynamic stop
 - Spindle stop method: Coast to a stop

0025 Absolute position data lost

Details

- The absolute position data was lost in the detector.
- Servo stop method: Initial error

0026 Unused axis error

Details

- In the multi-axis drive unit, there is an axis set to free, and the other axis detected a power module error.
- Servo stop method: Dynamic stop
 - Spindle stop method: Coast to a stop

0027 Machine side dtc: Error 5

Details

- An error was detected by the detector connected to the machine side.
The error details are different according to the detector type.
- Servo stop method: Dynamic stop
 - Spindle stop method: Coast to a stop
- [Detector alarm (Servo drive unit)]
- MDS-B-HR() Scale not connected
 - AT343, AT543, AT545(Mitsutoyo) CPU error
 - LC193M, LC493M, LC195M, LC495M, RCN223M, RCN227M, RCN727M, RCN827M, EIB Series(HEIDENHAIN) CPU error
 - MPRZ Scale(MHI) Absolute value detection fault
 - SAM/SVAM/GAM/LAN Series (FAGOR) CPU error
- [Detector alarm (Spindle drive unit)]
- MDS-B-HR() Connection error
 - EIB Series(HEIDENHAIN) CPU error
- (Note) A driver processes all reset types of alarms as "PR". However, "AR" will be applied according to the detector.

0028 Machine side dtc: Error 6

Details

An error was detected by the detector connected to the machine side.
The error details are different according to the detector type.

- Servo stop method: Dynamic stop
- Spindle stop method: Coast to a stop
- [Detector alarm (Servo drive unit)]
- AT343, AT543, AT545(Mitsutoyo) Photoelectric type overspeed
- LC193M, LC493M, LC195M, LC495M, RCN223M, RCN227M, RCN727M, RCN827M, EIB Series(HEIDENHAIN) Overspeed
- SR75, SR85, SR77, SR87, RU77(Magnescale) Over speed
- RL40N Series (Renishaw) Overspeed error
- [Detector alarm (Spindle drive unit)]
- TS5690, TS5691(MITSUBISHI) Overspeed
- EIB Series(HEIDENHAIN) Overspeed

(Note) A driver processes all reset types of alarms as "PR". However, "AR" will be applied according to the detector.

0029 Machine side dtc: Error 7

Details

An error was detected by the detector connected to the machine side.
The error details are different according to the detector type.

- Servo stop method: Dynamic stop
- Spindle stop method: Coast to a stop
- [Detector alarm (Servo drive unit)]
- AT343, AT543, AT545(Mitsutoyo) Static capacity type error
- LC193M, LC493M, LC195M, LC495M, RCN223M, RCN227M, RCN727M, RCN827M, EIB Series(HEIDENHAIN) Absolute position data error
- MPRZ Scale(MHI) Gain fault
- SR75, SR85, SR77, SR87, RU77(Magnescale) Absolute position data error
- [Detector alarm (Spindle drive unit)]
- MPC1 scale(MHI) Gain fault

(Note) A driver processes all reset types of alarms as "PR". However, "AR" will be applied according to the detector.

002A Machine side dtc: Error 8

Details

An error was detected by the detector connected to the machine side.
The error details are different according to the detector type.

- Servo stop method: Dynamic stop
- Spindle stop method: Coast to a stop
- [Detector alarm (Servo drive unit)]
- MBA405W(MITSUBISHI) Count error
- AT343, AT543, AT545(Mitsutoyo) Photoelectric type error
- LC193M, LC493M, LC195M, LC495M, RCN223M, RCN227M, RCN727M, RCN827M, EIB Series(HEIDENHAIN) Relative position data error
- MPRZ Scale(MHI) Phase fault
- SR75, SR85, SR77, SR87, RU77(Magnescale) Relative position data error
- [Detector alarm (Spindle drive unit)]
- TS5690, TS5691(MITSUBISHI) Relative position data error
- MBE405W(MITSUBISHI) Count error
- EIB Series(HEIDENHAIN) Relative position data error
- MPC1 scale(MHI) Phase fault

(Note) A driver processes all reset types of alarms as "PR". However, "AR" will be applied according to the detector.

002B Motor side dtc: Error 1

Details

An error was detected by the detector connected to the motor side.
The error details are different according to the detector type.

- Servo stop method: Dynamic stop
- Spindle stop method: Coast to a stop
- [Detector alarm (Servo drive unit)]
- OSA105, OSA105ET2A, OSA166, OSA166ET2NA(MITSUBISHI) Memory alarm
- OSA18() CPU alarm
- MDS-B-HR() Memory error
- AT343, AT543, AT545(Mitsutoyo) Initialization error
- LC193M, LC493M, RCN223M, RCN227M, RCN727M, RCN827M, EIB Series(HEIDENHAIN) Initialization error

- MPRZ Series(MHI) Installation accuracy fault
- SR75, SR85, SR77, SR87, RU77(Magnescale) Laser diode error

[Detector alarm (Spindle drive unit)]

- TS5690, TS5691(MITSUBISHI) Memory error
- MDS-B-HR() Initialization error
- OSA18() CPU error
- EIB Series(HEIDENHAIN) Initialization error
- MPC1 scale(MHI) Installation accuracy fault

(Note) A driver processes all reset types of alarms as "PR". However, "AR" will be applied according to the detector.

002C Motor side dtc: Error 2

Details

An error was detected by the detector connected to the motor side.
The error details are different according to the detector type.

- Servo stop method: Dynamic stop
- Spindle stop method: Coast to a stop
- [Detector alarm (Servo drive unit)]
- OSA105, OSA105ET2A, OSA166, OSA166ET2NA(MITSUBISHI) LED alarm
- AT343, AT543, AT545(Mitsutoyo) EEPROM error
- LC193M, LC493M, RCN223M, RCN227M, RCN727M, RCN827M, EIB Series(HEIDENHAIN) EEPROM error

- SR75, SR85, SR77, SR87, RU77(Magnescale) System memory error

[Detector alarm (Spindle drive unit)]

- TS5690, TS5691(MITSUBISHI) Waveform error
- EIB Series(HEIDENHAIN) EEPROM error

(Note) A driver processes all reset types of alarms as "PR". However, "AR" will be applied according to the detector.

002D Motor side dtc: Error 3

Details

An error was detected by the detector connected to the motor side.
The error details are different according to the detector type.

- Servo stop method: Dynamic stop
- Spindle stop method: Coast to a stop
- [Detector alarm (Servo drive unit)]
- OSA105, OSA105ET2A, OSA166, OSA166ET2NA(MITSUBISHI) Data alarm
- OSA18() Data alarm
- MDS-B-HR() Data error
- AT343, AT543, AT545(Mitsutoyo) Photoelectric type, static capacity type data mismatch
- LC193M, LC493M, RCN223M, RCN227M, RCN727M, RCN827M, EIB Series(HEIDENHAIN) Relative/ absolute position data mismatch

- MPRZ Series(MHI) Detection position deviance
- SR75, SR85, SR77, SR87, RU77(Magnescale) Encoder mismatch error
- SAM/SVAM/GAM/LAN Series (FAGOR) Absolute position detection error

[Detector alarm (Spindle drive unit)]

- MDS-B-HR() Data error
- OSA18() Data error
- MPC1 scale(MHI) Detection position deviance

(Note) A driver processes all reset types of alarms as "PR". However, "AR" will be applied according to the detector.

002E Motor side dtc: Error 4

Details

An error was detected by the detector connected to the motor side.
The error details are different according to the detector type.

- Servo stop method: Dynamic stop
 - Spindle stop method: Coast to a stop
 - [Detector alarm (Servo drive unit)]
 - AT343, AT543, AT545(Mitsutoyo) ROM/RAM error
 - LC193M, LC493M, RCN223M, RCN227M, RCN727M, RCN827M, EIB Series(HEIDENHAIN) ROM/RAM error
 - MPRZ Series(MHI) Scale breaking
 - SAM/SVAM/GAM/LAM Series (FAGOR) H/W error
 - [Detector alarm (Spindle drive unit)]
 - MPCl scale(MHI) Scale breaking
- (Note) A driver processes all reset types of alarms as "PR". However, "AR" will be applied according to the detector.

002F Motor side dtc: Commu error

Details

An error was detected in the communication with the motor side detector.

- Servo stop method: Dynamic stop
- Spindle stop method: Coast to a stop

0030 Over regeneration

Details

Over-regeneration level exceeded 100%. The regenerative resistor is overloaded.

- Servo stop method: Dynamic stop
- Spindle stop method: Coast to a stop

0031 Overspeed

Details

The motor speed exceeded the allowable speed.

- Servo stop method: Deceleration stop enabled
- Spindle stop method: Deceleration stop enabled

0032 Power module overcurrent

Details

The power module detected the overcurrent.

- Servo stop method: Dynamic stop
- Spindle stop method: Coast to a stop

0033 Overvoltage

Details

The bus voltage in main circuit exceeded the allowable value.

- Servo stop method: Dynamic stop
- Spindle stop method: Coast to a stop

0034 NC-DRV commu: CRC error

Details

The data received from the NC was outside the setting range.

- Servo stop method: Deceleration stop enabled
- Spindle stop method: Deceleration stop enabled

0035 NC command error

Details

The travel command data received from the NC was excessive.

- Servo stop method: Deceleration stop enabled
- Spindle stop method: Deceleration stop enabled

0036 NC-DRV commu: Commu error

Details

- The communication with the NC was interrupted.
- Servo stop method: Deceleration stop enabled
 - Spindle stop method: Deceleration stop enabled

0037 Initial parameter error

Details

- An incorrect set value was detected among the parameters send from the NC at the power ON.
In the SLS (Safely Limited Speed) function, an error was detected in the relation between the safety speed and safety rotation number in the speed observation mode.
- Servo stop method: Initial error
 - Spindle stop method: Initial error

0038 NC-DRV commu: Protocol error 1

Details

- An error was detected in the communication frames received from the NC.
Or, removing an axis or changing an axis was performed in the synchronous control.
- Servo stop method: Deceleration stop enabled
 - Spindle stop method: Deceleration stop enabled

0039 NC-DRV commu: Protocol error 2

Details

- An error was detected in the axis data received from the NC.
Or, in changing an axis, the parameter setting of the synchronous control was applied when the axis was installed.
- Servo stop method: Deceleration stop enabled
 - Spindle stop method: Deceleration stop enabled

003A Overcurrent

Details

- Excessive motor drive current was detected.
- Servo stop method: Dynamic stop
 - Spindle stop method: Coast to a stop

003B Power module overheat

Details

- The power module detected an overheat.
- Servo stop method: Dynamic stop
 - Spindle stop method: Coast to a stop

003C Regeneration circuit error

Details

- An error was detected in the regenerative transistor or in the regenerative resistor.
- Servo stop method: Dynamic stop

003D Pw sply volt err acc/dec

Details

- A motor control error during acceleration/deceleration, due to a power voltage failure, was detected.
- Servo stop method: Dynamic stop

003E Magnet pole pos detect err

Details

- The magnetic pole position, detected in the magnetic pole position detection control, is not correctly detected.
- Servo stop method: Dynamic stop
 - Spindle stop method: Coast to a stop

0041 Feedback error 3

Details

Either a missed feedback pulse in the motor side detector or an error in the Z-phase was detected in the full closed loop system.

- Servo stop method: Dynamic stop
- Spindle stop method: Coast to a stop

0042 Feedback error 1

Details

Either a missed feedback pulse in the position detection or an error in the Z-phase was detected. Or the distance-coded reference check error exceeded the allowable value when the distance-coded reference scale was used.

- Servo stop method: Dynamic stop
- Spindle stop method: Coast to a stop

0043 Feedback error 2

Details

An excessive difference in feedback was detected between the machine side detector and the motor side detector.

- Servo stop method: Dynamic stop
- Spindle stop method: Coast to a stop

0045 Fan stop

Details

An overheat of the power module was detected during the cooling fan stopping.

- Servo stop method: Dynamic stop
- Spindle stop method: Coast to a stop

0046 Motor overheat

Details

Either the motor or the motor side detector detected an overheat.

Or, the thermistor signal receiving circuit of the linear motor or DD motor was disconnected.

Or, the thermistor signal receiving circuit was short-circuited.

- Servo stop method: Deceleration stop enabled
- Spindle stop method: Deceleration stop enabled

0048 Motor side dtc: Error 5

Details

An error was detected by the detector connected to the main side.

The error details are different according to the connected detector.

- Servo stop method: Dynamic stop
- Spindle stop method: Coast to a stop

[Detector alarm (Servo drive unit)]

- MDS-B-HR() Scale not connected

- AT343, AT543, AT545(Mitsutoyo) CPU error

- LC193M, LC493M, RCN223M, RCN227M, RCN727M, RCN827M, EIB Series(HEIDENHAIN) CPU error

- MPRZ Series(MHI) Absolute value detection fault

- SAM/SVAM/GAM/LAM Series (FAGOR) CPU error

[Detector alarm (Spindle drive unit)]

- MDS-B-HR() Connection error

- EIB Series(HEIDENHAIN) CPU error

(Note) A driver processes all reset types of alarms as "PR". However, "AR" will be applied according to the detector.

0049 Motor side dtc: Error 6

Details

An error was detected by the detector connected to the main side.
The error details are different according to the connected detector.

- Servo stop method: Dynamic stop
- Spindle stop method: Coast to a stop
- [Detector alarm (Servo drive unit)]
- AT343, AT543, AT545(Mitsutoyo) Photoelectric type overspeed
- LC193M, LC493M, RCN223M, RCN227M, RCN727M, RCN827M, EIB Series(HEIDENHAIN) Overspeed
- SR75, SR85, SR77, SR87, RU77(Magnescale) Over speed
- [Detector alarm (Spindle drive unit)]
- TS5690, TS5691(MITSUBISHI) Overspeed
- EIB Series(HEIDENHAIN) Overspeed

(Note) A driver processes all reset types of alarms as "PR". However, "AR" will be applied according to the detector.

004A Motor side dtc: Error 7

Details

An error was detected by the detector connected to the main side.
The error details are different according to the connected detector.

- Servo stop method: Dynamic stop
- Spindle stop method: Coast to a stop
- [Detector alarm (Servo drive unit)]
- AT343, AT543, AT545(Mitsutoyo) Static capacity type error
- LC193M, LC493M, RCN223M, RCN227M, RCN727M, RCN827M, EIB Series(HEIDENHAIN) Absolute position data error
- MPRZ Series(MHI) Gain fault
- SR75, SR85, SR77, SR87, RU77(Magnescale) Absolute position data error
- [Detector alarm (Spindle drive unit)]
- MPCI scale(MHI) Gain fault

(Note) A driver processes all reset types of alarms as "PR". However, "AR" will be applied according to the detector.

004B Motor side dtc: Error 8

Details

An error was detected by the detector connected to the main side.
The error details are different according to the connected detector.

- Servo stop method: Dynamic stop
- Spindle stop method: Coast to a stop
- [Detector alarm (Servo drive unit)]
- AT343, AT543, AT545(Mitsutoyo) Photoelectric type error
- LC193M, LC493M, RCN223M, RCN227M, RCN727M, RCN827M, EIB Series(HEIDENHAIN) Relative position data error
- MPRZ Series(MHI) Phase fault
- SR75, SR85, SR77, SR87, RU77(Magnescale) Relative position data error
- [Detector alarm (Spindle drive unit)]
- TS5690, TS5691(MITSUBISHI) Relative position data error
- EIB Series(HEIDENHAIN) Relative position data error
- MPCI scale(MHI) Phase fault

(Note) A driver processes all reset types of alarms as "PR". However, "AR" will be applied according to the detector.

004C Current err mag pole estim

Details

Current detection failed at the initial magnetic pole estimation.

- Servo stop method: Dynamic stop
- Spindle stop method: Coast to a stop

004D Dual signal error

Details

An error was detected in the signal related to the dual signal.

- Servo stop method: Dynamic stop
- Spindle stop method: Coast to a stop

004E NC command mode error

Details

- An error was detected in the control mode send from the NC.
- Servo stop method: Deceleration stop enabled
- Spindle stop method: Deceleration stop enabled

004F Instantaneous power interrupt

Details

- The control power supply has been shut down for 50ms or more.
- Servo stop method: Deceleration stop enabled
- Spindle stop method: Deceleration stop enabled

0050 Overload 1

Details

- Overload detection level became 100% or more. The motor or the drive unit is overloaded.
- Servo stop method: Deceleration stop enabled
- Spindle stop method: Deceleration stop enabled

0051 Overload 2

Details

- In a servo system, current command of 95% or more of the unit's max. current was given continuously for 1 second or longer. In a spindle system, current command of 95% or more of the motor's max. current was given continuously for 1 second or longer.
- Servo stop method: Deceleration stop enabled
- Spindle stop method: Deceleration stop enabled

0052 Excessive error 1

Details

- A position tracking error during servo ON was excessive.
- Servo stop method: Deceleration stop enabled
- Spindle stop method: Deceleration stop enabled

0053 Excessive error 2

Details

- A position tracking error during servo OFF was excessive.
- Servo stop method: Dynamic stop

0054 Excessive error 3

Details

- There was no motor current feedback when the alarm "Excessive error 1" was detected.
- Servo stop method: Dynamic stop
- Spindle stop method: Coast to a stop

0056 Commanded speed error

Details

- In the C-axis control mode, excessive speed error was detected.
- Spindle stop method: Deceleration stop enabled

0058 Collision detection 1: G0

Details

- A disturbance torque exceeded the allowable value in rapid traverse modal (G0).
- Servo stop method: Maximum capacity deceleration stop

0059 Collision detection 1: G1

Details

- A disturbance torque exceeded the allowable value in the cutting feed modal (G1).
- Servo stop method: Maximum capacity deceleration stop

005A Collision detection 2

Details

A current command with the maximum drive unit current value was detected.
- Servo stop method: Maximum capacity deceleration stop

005B Safely limited: Cmd spd err

Details

A commanded speed exceeding the safely limited speed was detected in the safely limited mode.
- Servo stop method: Deceleration stop enabled
- Spindle stop method: Deceleration stop enabled

005D Safely limited: Door stat err

Details

The door state signal input in the NC does not coincide with the door state signal input in the drive unit in the safely limited mode. Otherwise, door open state was detected in normal mode.
- Servo stop method: Deceleration stop enabled
- Spindle stop method: Deceleration stop enabled

005E Safely limited: FB speed err

Details

A motor speed exceeding the safely limited speed was detected in the safely limited mode.
- Servo stop method: Deceleration stop enabled
- Spindle stop method: Deceleration stop enabled

005F External contactor error

Details

A contact of the external contactor is welding.
- Servo stop method: Deceleration stop enabled
- Spindle stop method: Deceleration stop enabled

0080 Motor side dtc: cable err

Details

The cable type of the motor side detector cable is for rectangular wave signal.
- Servo stop method: Initial error

0081 Machine side dtc: cable err

Details

The cable type of the machine side detector cable does not coincide with the detector type which is set by the parameter.
- Servo stop method: Initial error

0087 Drive unit communication error

Details

The communication frame between drive units was aborted.
- Servo stop method: Dynamic stop
- Spindle stop method: Coast to a stop

0088 Watchdog

Details

The drive unit does not operate correctly.
- Servo stop method: Dynamic stop
- Spindle stop method: Coast to a stop

008A Drivers commu data error 1

Details

The communication data 1 between drivers exceeded the tolerable value in the communication between drive units.
- Servo stop method: Dynamic stop
- Spindle stop method: Coast to a stop

008B Drivers commu data error 2

Details

The communication data 2 between drivers exceeded the tolerable value in the communication between drive units.

- Servo stop method: Dynamic stop
- Spindle stop method: Coast to a stop

Power supply alarms

0061 Pw sply: Pwr module overcurrnt

Details

Overcurrent protection function in the power module has started its operation.

0062 Pw sply: Frequency error

Details

The input power supply frequency increased above the specification range.

0066 Pw sply: Process error

Details

An error occurred in the process cycle.

0067 Pw sply: Phase interruption

Details

An open-phase condition was detected in input power supply circuit.

0068 Pw sply: Watchdog

Details

The system does not operate correctly.

0069 Pw sply: Grounding

Details

The motor power cable is in contact with FG (Frame Ground).

006A Pw sply: Ext contactor weld

Details

A contact of the external contactor is welding.

006B Pw sply: Rush circuit error

Details

An error was detected in the rush circuit.

006C Pw sply: Main circuit error

Details

An error was detected in charging operation of the main circuit capacitor.

006D Pw sply: Parameter error

Details

An error was detected in the parameter sent from the drive unit.

006E Pw sply: H/W error

Details

An error was detected in the internal memory.
An error was detected in the A/D converter.
An error was detected in the unit identification.

006F Power supply error

Details

No power supply is connected to the drive unit, or a communication error was detected.

0070 Pw sply: External EMG stop err

Details

A mismatch of the external emergency stop input and NC emergency stop input continued for 30 seconds.

0071 Pw sply: Instant pwr interrupt**Details**

The power was momentarily interrupted.

0072 Pw sply: Fan stop**Details**

A cooling fan built in the power supply unit stopped, and overheat occurred in the power module.

0073 Pw sply: Over regeneration**Details**

Over-regeneration detection level became over 100%. The regenerative resistor is overloaded. This alarm cannot be reset for 15 min from the occurrence to protect the regeneration resistor. Leave the drive system energized for more than 15 min, then turn the power ON to reset the alarm.

0074 Pw sply: Option unit error**Details**

An alarm was detected in the power backup unit (power supply option unit).
Check the LED display on the power backup unit to identify what alarm is occurring to the unit. Refer to the instruction manual of your drive unit for details.

0075 Pw sply: Overvoltage**Details**

L+ and L- bus voltage in main circuit exceeded the allowable value. As the voltage between L+ and L- is high immediately after this alarm, another alarm may occur if this alarm is reset in a short time. Wait more than 5 min before resetting so that the voltage drops.

0076 Pw sply: Function setting err**Details**

The rotary switch setting of external emergency stop is not correct, or a wrong external emergency stop signal is input.
Undefined number was selected for the rotary switch setting of the power supply.

0077 Pw sply: Power module overheat**Details**

Thermal protection function in the power module has started its operation.

Appendix 6.3.2 Initial Parameter Errors (S02)

S02 Initial parameter error:PR 2201-2456 (Axis name)

Details

The servo parameter setting data is illegal.
The alarm No. is the No. of the servo parameter where the error occurred.

Remedy

Check the descriptions for the appropriate servo parameters and correct them.
Even when the parameter is set to a value within the setting range, an error is occurring due to the hardware compatibility or specifications or in relation to several other parameters.
Refer to "Parameter Numbers during Initial Parameter Error" of each drive unit instruction manual for details.

S02 Initial parameter error:PR 13001-13256 (Axis name)

Details

Parameter error
The spindle parameter setting data is illegal.
The alarm No. is the No. of the spindle parameter where the error occurred.

Remedy

Check the descriptions for the appropriate spindle parameters and correct them.
Even when the parameter is set to a value within the setting range, an error is occurring due to the hardware compatibility or specifications or in relation to several other parameters.
Refer to "Parameter Numbers during Initial Parameter Error" of each drive unit instruction manual for details.

Appendix 6.3.3 Safety Function Errors (S05)

S05 Safety function error:NR 0001 (Axis name)

Details

The STO signal has been input through the CN8 connector.

Remedy

Make sure that a short-circuiting connector has been inserted into CN8.

Appendix 6.3.4 Parameter Errors (S51)

S51 Parameter error 2201-2456 (Axis name)

Details

Servo parameter setting data is illegal.

The alarm No. is the No. of the servo parameter where the warning occurred.

Remedy

Check the descriptions for the appropriate servo parameters and correct them.

Even when the parameter is set to a value within the setting range, an error is occurring due to the hardware compatibility or specifications or in relation to several other parameters.

Refer to "Parameter Numbers during Initial Parameter Error" of each drive unit instruction manual for details.

S51 Parameter error 13001-13256 (Axis name)

Details

Spindle parameter setting data is illegal.

The alarm No. is the No. of the spindle parameter where the warning occurred.

Remedy

Check the descriptions for the appropriate spindle parameters and correct them.

Even when the parameter is set to a value within the setting range, an error is occurring due to the hardware compatibility or specifications or in relation to several other parameters.

Refer to "Parameter Numbers during Initial Parameter Error" of each drive unit instruction manual for details.

Appendix 6.3.5 Servo Warnings (S52)

Servo warning is displayed in the following format.

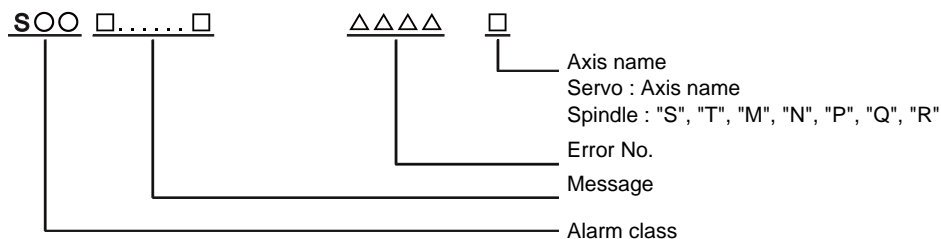

Alarm class	Message
S52	Servo warning

Error No. consists of four digits (0096 to). Servo warnings are explained in ascending order of the error No. The four digits on the left part of each warning indicate the error No.

(Note) For the details of servo warnings, refer to your drive unit's instruction manual.

Drive unit warnings

0096 Scale feedback error

Details

An excessive difference in feedback amount was detected between the main side detector and the MPI scale in MPI scale absolute position detection system.
- Reset method: Automatically reset once the cause of the warning is removed.

0097 Scale offset error

Details

An error was detected in the offset data that is read at the NC power-ON in MPI scale absolute position detection system.

009B Detec cnv: Mag pole shift warn

Details

The difference between the magnetic pole position after the phase Z has been passed (magnetic pole shift amount:SV028) and the initially detected position is excessive in the built-in motor's incremental control system. The magnetic pole is controlled by the initial detection value.
- Reset method: Automatically reset once the cause of the warning is removed.

009E Abs pos dtc: Rev count error

Details

An error was detected in the revolution counter data of the absolute position detector. The accuracy of absolute position is not guaranteed.
- Reset method: Automatically reset once the cause of the warning is removed.

009F Battery voltage drop

Details

The battery voltage to be supplied to the absolute position detector is dropping.

00A3 In initial setup of ABS posn.

Details

This warning is detected until the axis reaches the reference position during the initial setup of the distance-coded reference check function. This warning turns OFF after the axis has reached the position, thus set the value displayed on the drive monitor to the parameter.
This warning is detected during the initial setup of MBA405W. This warning turns OFF after the initial setup is completed by having the axis pass the Z-phase of MBA405W and turning the NC power ON again.
- Reset method: Automatically reset once the cause of the warning is removed.

00A4 Dual signal warning

Details

An input was detected in the signal related to the dual signal.
 - Reset method: Automatically reset once the cause of the warning is removed.

00A6 Fan stop warning

Details

A cooling fan in the drive unit stopped.
 - Reset method: Automatically reset once the cause of the warning is removed.

00E0 Over regeneration warning

Details

Over-regeneration detection level exceeded 80%.
 - Reset method: Automatically reset once the cause of the warning is removed.

00E1 Overload warning

Details

A level of 80% of the Overload 1 alarm state was detected.
 - Reset method: Automatically reset once the cause of the warning is removed.

00E4 Set parameter warning

Details

An incorrect set value was detected among the parameters send from the NC in the normal operation.
 - Reset method: Automatically reset once the cause of the warning is removed.

00E6 Control axis detach warning

Details

A control axis is being detached. (State display)
 - Reset method: Automatically reset once the cause of the warning is removed.

00E7 In NC emergency stop state

Details

In NC emergency stop. (State display)
 - Stop method: Deceleration stop enabled
 - Reset method: Automatically reset once the cause of the warning is removed.

00E8-00EF Power supply warning

Details

The power supply unit detected a warning. The error details are different according to the connected power supply unit.
 Refer to "Power supply warning".
 - Stop method: - (EA: Deceleration stop enabled)
 - Reset method: Automatically reset once the cause of the warning is removed.

Power supply warnings

00E9 Instant pwr interrupt warning

Details

The power was momentarily interrupted.

00EA In external EMG stop state

Details

External emergency stop signal was input.

- Reset method: Automatically reset once the cause of the warning is removed.

00EB Pw sply: Over regenerat warn

Details

Over-regeneration detection level exceeded 80%.

- Reset method: Automatically reset once the cause of the warning is removed.

00EE Pw sply: Fan stop warning

Details

A cooling fan built in the power supply unit stopped.

- Reset method: Automatically reset once the cause of the warning is removed.

00EF Pw sply: Option unit warning

Details

A warning is detected in the power backup unit (power supply option unit).

Check the LED display on the power backup unit to identify what alarm is occurring to the unit. Refer to the using drive unit instruction manual for details.

Appendix 6.3.6 Safety Function Warnings (S53)

S53 Safety function warning 0001 (Axis name)

Details

The system has been set in the STO state.

The STO state is also entered at the time of emergency stop, but in this case, this warning will not appear because the emergency stop has priority.

Appendix 6.4 MCP Alarms (Y)

Y02 System alm: Process time over 0050

Details

System alarm: Process time is over.

Remedy

The software or hardware may be damaged.
Contact the service center.

(Note) When two or more "Y02 System alarms" occur at the same time, only the alarm which has occurred first is displayed.

Y02 SV commu er: CRC error 1 0051 0000

Details

A communication error has occurred between controller and drive unit.

Remedy

- Take measures against noise.
- Check for any failure of the communication cable connectors between controller and drive unit or between two drive units.
- Check for any failure of the communication cables between controller and drive unit or between two drive units.
- A drive unit may be faulty. Take a note of the 7-segment LED contents of each drive unit and contact the Service Center.
- Update the drive unit software version.

(Note) When two or more "Y02 System alarms" occur at the same time, only the alarm which has occurred first is displayed.

Y02 SV commu er: CRC error 2 0051 0001

Details

A communication error has occurred between controller and drive unit.

Remedy

- Take measures against noise.
- Check for any failure of the communication cable connectors between controller and drive unit or between two drive units.
- Check for any failure of the communication cables between controller and drive unit or between two drive units.
- A drive unit may be faulty. Take a note of the 7-segment LED contents of each drive unit and contact the Service Center.
- Update the drive unit software version.

(Note) When two or more "Y02 System alarms" occur at the same time, only the alarm which has occurred first is displayed.

Y02 SV commu er: Recv timing err 0051 0002

Details

A communication error has occurred between controller and drive unit.

Remedy

- Take measures against noise.
- Check for any failure of the communication cable connectors between controller and drive unit or between two drive units.
- Check for any failure of the communication cables between controller and drive unit or between two drive units.
- A drive unit may be faulty. Take a note of the 7-segment LED contents of each drive unit and contact the Service Center.
- Update the drive unit software version.

(Note) When two or more "Y02 System alarms" occur at the same time, only the alarm which has occurred first is displayed.

Y02 SV commu er: Data ID error 0051 xy03

Details

A communication error has occurred between controller and drive unit.

x: Channel No. (0 to

y: Drive unit rotary switch No. (0 to)

Remedy

- Take measures against noise.
- Check for any failure of the communication cable connectors between controller and drive unit or between two drive units.
- Check for any failure of the communication cables between controller and drive unit or between two drive units.
- A drive unit may be faulty. Take a note of the 7-segment LED contents of each drive unit and contact the Service Center.
- Update the drive unit software version.

(Note) When two or more "Y02 System alarms" occur at the same time, only the alarm which has occurred first is displayed.

Y02 SV commu er: Recv frame No. 0051 xy04

Details

A communication error has occurred between controller and drive unit.

x: Channel No. (from 0)

y: Drive unit rotary switch No. (from 0)

Remedy

- Take measures against noise.
- Check for any failure of the communication cable connectors between controller and drive unit or between two drive units.
- Check for any failure of the communication cables between controller and drive unit or between two drive units.
- A drive unit may be faulty. Take a note of the 7-segment LED contents of each drive unit and contact the Service Center.
- Update the drive unit software version.

(Note) When two or more "Y02 System alarms" occur at the same time, only the alarm which has occurred first is displayed.

Y02 SV commu er: Commu error 0051 x005

Details

A communication error has occurred between controller and drive unit.

x: Channel No. (from 0)

Remedy

- Take measures against noise.
- Check for any failure of the communication cable connectors between controller and drive unit or between two drive units.
- Check for any failure of the communication cables between controller and drive unit or between two drive units.
- A drive unit may be faulty. Take a note of the 7-segment LED contents of each drive unit and contact the Service Center.
- Update the drive unit software version.

(Note) When two or more "Y02 System alarms" occur at the same time, only the alarm which has occurred first is displayed.

Y02 SV commu er: Connect error 0051 x006

Details

A communication error has occurred between controller and drive unit.

x: Channel No. (from 0)

Remedy

- Take measures against noise.
- Check for any failure of the communication cable connectors between controller and drive unit or between two drive units.
- Check for any failure of the communication cables between controller and drive unit or between two drive units.
- A drive unit may be faulty. Take a note of the 7-segment LED contents of each drive unit and contact the Service Center.
- Update the drive unit software version.

(Note) When two or more "Y02 System alarms" occur at the same time, only the alarm which has occurred first is displayed.

Y02 SV commu er : Init commu error 0051 xy20**Details**

A communication error has occurred between controller and drive unit.
 A drive unit stopped due to transition failure from initial communication to runtime.
 x: Channel No. (from 0)
 y: Drive unit rotary switch No. (from 0)

Remedy

- Take measures against noise.
- Check for any failure of the communication cable connectors between controller and drive unit or between two drive units.
- Check for any failure of the communication cables between controller and drive unit or between two drive units.
- A drive unit may be faulty. Take a note of the 7-segment LED contents of each drive unit and contact the Service Center.
- Update the drive unit software version.

(Note) When two or more "Y02 System alarms" occur at the same time, only the alarm which has occurred first is displayed.

Y02 SV commu er: Node detect error 0051 xy30**Details**

A communication error has occurred between controller and drive unit.
 No response from drive unit to the request from NC when setting network configuration.
 x: Channel No. (from 0)
 y: Station No. (from 0)

Remedy

- Take measures against noise.
- Check for any failure of the communication cable connectors between controller and drive unit or between two drive units.
- Check for any failure of the communication cables between controller and drive unit or between two drive units.
- A drive unit may be faulty. Take a note of the 7-segment LED contents of each drive unit and contact the Service Center.
- Update the drive unit software version.

(Note) When two or more "Y02 System alarms" occur at the same time, only the alarm which has occurred first is displayed.

Y02 SV commu er: Commu not support 0051 xy31**Details**

A communication error has occurred between controller and drive unit.
 Drive unit's software version doesn't support the communication mode that the controller requires.
 x: Channel No. (from 0)
 y: Station No. (from 0)

Remedy

- Take measures against noise.
- Check for any failure of the communication cable connectors between controller and drive unit or between two drive units.
- Check for any failure of the communication cables between controller and drive unit or between two drive units.
- A drive unit may be faulty. Take a note of the 7-segment LED contents of each drive unit and contact the Service Center.
- Update the drive unit software version.

(Note) When two or more "Y02 System alarms" occur at the same time, only the alarm which has occurred first is displayed.

Y02 System alarm 0052 0001**Details**

Transfer to buffer is not properly done in servo communication.

Remedy

Software/ hardware may have a fault.
 Contact service center.

(Note) When two or more "Y02 System alarms 0051" alarms occur at the same time, only the alarm which occurs first is displayed.

Y03 Drive unit unequipped axis name

Details

The drive unit is not correctly connected.
Alphabet (axis name): Servo axis drive unit not mounted
1 to 4: PLC axis drive unit not mounted
S: No.1 spindle drive unit not mounted
T: No.2 spindle drive unit not mounted
M: No.3 spindle drive unit not mounted
N: No.4 spindle drive unit not mounted

Remedy

Check the drive unit mounting state.
- Check the end of the cable wiring.
- Check for any broken wires.
- Check the connector insertion.
- The drive unit input power has not been ON.
- The drive unit axis No. switch is illegal.

Y05 Initial parameter error 3025

Details

The type of the spindle detector of the reference spindle or G/B spindle is not the one for connecting with a spindle drive unit.

Remedy

Check the detectors of the reference spindle and G/B spindle whether it can be connected to the spindle drive unit or not (#3025 enc-on=2).

Y05 Initial parameter error

Details

There is a problem in the value set for the number of axes or the number of part systems.

Remedy

Correct the value set for the following corresponding parameters:
"#1001 SYS_ON (System validation setup)",
"#1002 axisno (Number of axes)",
"#1039 spinno (Number of spindles)", etc.

Y06 mcp_no setting error 0001

Details

There is a skipped number in the channels.

Remedy

Check the values set for the following parameters.
"#1021 mcp_no (Drive unit I/F channel No. (servo))"
"#3031 smcp_no (Drive unit I/F channel No. (spindle))"

Y06 mcp_no setting error 0002

Details

There is a duplicate setting for random layout.

Remedy

Check the values set for the following parameters.
"#1021 mcp_no (Drive unit I/F channel No. (servo))"
"#3031 smcp_no (Drive unit I/F channel No. (spindle))"

Y06 mcp_no setting error 0003

Details

The drive unit fixed setting "0000" and random layout setting "*****" are both set.

Remedy

Check the values set for the following parameters.
"#1021 mcp_no (Drive unit I/F channel No. (servo))"
"#3031 smcp_no (Drive unit I/F channel No. (spindle))"

Y06 mcp_no setting error 0004

Details

The spindle/C axis "#1021 mcp_no (Drive unit I/F channel No. (servo))" and "#3031 smcp_no (Drive unit I/F channel No. (spindle))" are not set to the same values.

Remedy

Check the values set for the following parameters.
 "#1021 mcp_no (Drive unit I/F channel No. (servo))"
 "#3031 smcp_no (Drive unit I/F channel No. (spindle))"

Y06 mcp_no setting error 0005

Details

A random layout has been set while "#1154 pdoor" has been set to "1" in two-part system.

Remedy

Check the values set for the following parameters.
 "#1021 mcp_no (Drive unit I/F channel No. (servo))"
 "#3031 smcp_no (Drive unit I/F channel No. (spindle))"

Y06 mcp_no setting error 0006

Details

The channel No. parameter is not within the setting range.

Remedy

Check the values set for the following parameters.
 "#1021 mcp_no (Drive unit I/F channel No. (servo))"
 "#3031 smcp_no (Drive unit I/F channel No. (spindle))"

Y07 Too many axes connected 00xy

Details

The number of axes connected to each channel exceeds the maximum number of connectable axes. The exceeded number of axes per channel is displayed as alarm No.

- x: Exceeded number of axes at drive unit interface channel 2 (0 to F)
- y: Exceeded number of axes at drive unit interface channel 1 (0 to F)

This alarm also occurs when the drive unit is connected only with the 2nd channel without connecting with the 1st channel.

Remedy

Remove connected axes from the channel whose alarm No. is other than '0' for the number displayed as the alarm No. Keep the number of connected axes to or less than the maximum that can be connected.

(Note 1) The number of axes is limited per each drive unit interface channel.

(Note 2) Maximum number of axes that can be connected differs depending on whether or not an expansion unit is available or the setting of '#11012 16 axes for 1ch (Connecting 16 axes for 1ch)'.

With the expansion unit, up to eight axes can be connected to a channel. Without the expansion unit, up to eight axes are allowed when '#11012 16 axes for 1ch (Connecting 16 axes for 1ch)' is set to '0', sixteen axes when set to '1'.

(Note 3) If this alarm occurs, the alarm 'Y03 Message: Drive unit unequipped' will not occur.

(Note 4) This alarm is displayed taking precedence over the alarm 'Y08 Too many drive units connected' and 'Y09 Too many axisno connected'.

Y08 Too many drive units connected 00xy

Details

The number of drive units connected to each channel exceeds 8.
The exceeded number of drive units per channel is displayed as alarm No.
x: Exceeded number of drive units at drive unit interface channel 2 (0 to F)
y: Exceeded number of drive units at drive unit interface channel 1 (0 to F)

Remedy

Remove drive units from the channel whose alarm No. is other than "0" for the number displayed as the alarm No. Keep the number of connected drive units to 8 or less.
(Note 1) The drive unit is not counted when all the axes connected to it are invalid.
(Note 2) If this alarm occurs, the alarm "Y03 Message: Drive unit unequipped" will not occur.
(Note 3) The alarm "Y07 Too many axes connected" and "Y09 Too many axisno connected" are displayed taking precedence over this alarm.

Y09 Too many axisno connected 00xy

Details

The No. of the axis (drive unit's rotary switch No.) connected to each channel is bigger than the No. allowed.
If the axis No. of each channel is bigger than the No. allowed, "1" is displayed for the alarm No.
x: "1" when the axis No. at drive unit interface channel 2 is too big
y: "1" when the axis No. at drive unit interface channel 1 is too big

Remedy

For the channel whose alarm No. is "1", keep the axis No. (drive unit's rotary switch No.) not bigger than the No. allowed.
(Note 1) The axis No. is limited per each drive unit interface channel.
(Note 2) The biggest allowed connected axis No. differs depending on whether or not an expansion unit is available or the setting of "#11012 16 axes for 1ch (Connecting 16 axes for 1ch)". The biggest connectable axis No. is as shown below.
With the expansion unit, axes No. '0' to '7' can be connected.
Without the expansion unit, axes No. '0' to '7' are allowed when '#11012 16 axes for 1ch (Connecting 16 axes for 1ch)' is set to '0', axes No. '0' to 'F' when set to '1'.
(Note 3) If this alarm occurs, the alarm "Y03 Message: Drive unit unequipped" will not occur.
(Note 4) This alarm is displayed taking precedence over the alarm "Y08 Too many drive units connected".
(Note 5) The alarm "Y07 Too many axes connected" is displayed taking precedence over this alarm.

Y11 Node Detect Err 8002-8300 xy00

Details

Drive unit does not respond to the request from NC when the NC is turned ON.
Error No. shows the No. of communication phase at which the response stopped.
x: Channel No. (0 or later)
y: Station No. with the error (0 or later)

Remedy

The communication error may be caused by the drive unit software version that does not correspond to the NC software version. Check the drive unit software version.
This alarm is canceled after the NC restarts.
When the alarm is not canceled, write down the alarm No. and contact service center.

Y12 No commu. with axis drv unit

Details

Although the high-speed synchronous tapping option is valid, the connected drive unit doesn't support the option.

Remedy

Replace the drive unit with that supports the option.

Y13 No commu. with sp drv unit

Details

Although the high-speed synchronous tapping option is valid, the connected drive unit doesn't support the option.

Remedy

Replace the drive unit with that supports the option.

Y14 Comm btwn drives not ready**Details**

Communication between drive units failed to be ready within a specified time.

Remedy

- There may be a faulty connection of drive units.
- Check if any of drive units is broken.

Y20 Parameter compare error 0001 (Axis name)**Details**

The speed monitoring parameter in the NC does not correspond to the parameter transmitted to the drive unit.

The name of the axis with an error is displayed.

Remedy

The NC or the servo drive unit may be damaged.
Contact the service center.

Y20 Sfty obsrvation: Cmd spd err 0002 (Axis name)**Details**

The speed exceeding the speed set with the parameter was commanded during the speed monitoring mode.

The name of the axis with an error is displayed.

Remedy

Check the speed monitoring parameter and the sequence program.
Restart the NC.

Y20 Sfty obsrvation: FB pos err 0003 (Axis name)**Details**

The commanded position, transmitted to the servo drive unit from NC, is totally different from the feedback position received from the servo drive unit during the speed monitoring mode.

The name of the axis with an error is displayed.

Remedy

The NC or the servo drive unit may be damaged.
Contact the service center.

Y20 Sfty obsrvation: FB speed err 0004 (Axis name)**Details**

Actual rotation speed of the motor is exceeding the speed that has been set with speed monitoring parameter during the speed monitoring mode.

The name of the axis with an error is displayed.

Remedy

Correct the speed observation parameter and the sequence program.
Restart the NC.

Y20 Door signal: Input mismatch 0005 Door No.**Details**

Door state signals on the NC side and the drive side do not match. It may be caused by the followings:

- Cable disconnection
- Damaged door switch
- Damaged NC or servo drive unit

Remedy

Check the cable.
Check the door switch.
Restart the NC.

Y20 No speed observation mode in door open 0006 Door No.

Details

The door open state was detected when the speed monitoring mode was invalid.
The causes may be same as the ones for 0005 (Door signal: Input mismatch). Also the sequence program may not be correct.

Remedy

Correct the sequence program.
Restart the NC.

Y20 Speed obsv: Para incompatible 0007 (Axis name)

Details

Two speed monitoring parameters are not matched at the rising edge of the "speed monitor mode" signal.
The name of the axis with an error is displayed.

Remedy

Correct the relevant parameters so that the two speed monitoring parameters match.
Restart the NC.

Y20 Contactor welding detected 0008 Contactor No.

Details

Contactor welding was detected.
Displays the bit corresponding to the No. of the abnormal contactor.
Some contactors take a while to be shutdown after the servo ready is turned OFF, and the servo ready was turned ON in the meantime.

Remedy

- Make sure that contactor's auxiliary B contact signal is output correctly to the device set on "#1330 MC_dp1(Contactor weld detection device 1)" and "#1331 MC_dp2(Contactor weld detection device 2)".
- If welding, replace the contactor.
- Restart the NC.

Y20 No spec: Safety observation 0009

Details

"#2313 SV113 SSF8/bitF (ssc SLS (Safely Limited Speed) function)" and "#13229 SP229 SFNC9/bitF (ssc SLS (Safely Limited Speed) function)" are set for a system with no safety observation option.

Remedy

Disable "#2313 SV113 SSF8/bitF (ssc SLS (Safely Limited Speed) function)" and "#13229 SP229 SFNC9/bitF (ssc SLS (Safely Limited Speed) function)".
Then, restart the NC.

Y20 SDIO connector input volt err 0010

Details

24VDC power is not supplied to SDIO connector correctly. (SDIO 4A pin supply voltage was dropped to 16V or less, or 1ms or more instant power interrupt was detected.)
In this case, "Pw sply:Inst pw interpt(DC24V)" alarm occurs because the contactor control output signal cannot be controlled.
This state remains until restarting the NC even if the cause of the alarm has been removed.

Remedy

Check the wiring. Supply 24VDC power to the SDIO connector.
Restart the NC.

Y20 Device setting illegal 0011

Details

- The device set in "#1353 MC_ct1 (Contactor shutoff output 1 device)" does not exist.
- The device set in "#1353 MC_ct1 (Contactor shutoff output 1 device)" is used as an output device in PLC program.

Remedy

- In "#1353 MC_ct1 (Contactor shutoff output 1 device)", set the device to which a remote I/O is connected. Use the device to control the contactor.
- Confirm that the devices set by "#1353 MC_ct1 (Contactor shutoff output 1 device)" are not used as an output device in PLC program.

Y20 Contactor operation abnormal 0012 Contactor No.

Details

Contactor's operation is not following the NC's commands.
Displays the No. of the abnormal contactor.

Remedy

- Check and correct "#1353 MC_ct1 (Contactor shutoff output 1 device)" setting.
- Check the wiring for contactor shutoff.
- Check for contactor's welding.

Y20 STO function operation illegal 0013

Details

The drive unit's STO function has failed to work properly.

Remedy

If this alarm has occurred alone, a drive unit failure can be suspected.
If other alarms have been generated at the same time, it is also possible that there is communication problem. Check the optical cable wiring.

Y20 STO function illegal at pwr ON 0014

Details

The motor power has not been shut down with the STO function when the NC power was turned ON.

Remedy

If this alarm has occurred alone, a drive unit failure can be suspected.
If other alarms have been generated at the same time, it is also possible that there is communication problem. Check the optical cable wiring.

Y20 Dual signal: parameter setting error 0027

Details

A setting of #2118 SscDrSel, #3071 SscDrSelSp, #2180 S_DIN, or #3140 S_DINSp is not correct.

Remedy

- Correct the parameter setting.

Y20 Safety observation: parameter memory error 0031 (Parameter No.)

Details

The following parameters are not consistent with the check data.
#2180 S_DIN, #3140 S_DINSp

Remedy

- Correct the parameter setting.
- Restore the backup data, as the parameter or check data may be corrupted.

Y21 Speed obsv signal: Speed over 0001 (Axis name)

Details

The speed exceeds the safety speed limit when the "speed monitor mode" signal is ON.
The name of the axis with an error is displayed.

Remedy

Decelerate the speed to reset the warning and start the speed monitor.

Y51 Parameter G0tL illegal 0001

Details

The time constant has not been set or exceeded the setting range.

Remedy

Correct "#2004 G0tL (G0 time constant (linear))".

Y51 Parameter G1tL illegal 0002

Details

The time constant has not been set or exceeded the setting range.

Remedy

Correct "#2007 G1tL (G1 time constant (linear))".

Y51 Parameter G0t1 illegal 0003

Details

The time constant has not been set or exceeded the setting range.

Remedy

Correct "#2005 G0t1 (G0 time constant (primary delay) / Second-step time constant for soft acceleration/deceleration)".

Y51 Parameter G1t1 illegal 0004

Details

The time constant has not been set or exceeded the setting range.

Remedy

Correct "#2008 G1t1 (G1 time constant (primary delay)/Second-step time constant for soft acceleration/deceleration)".

Y51 Parameter grid space illegal 0009

Details

The grid space is illegal.

Remedy

Correct "#2029 grspc(Grid interval)".

Y51 Parameter stapt1-4 illegal 0012

Details

The time constant has not been set or exceeded the setting range.

Remedy

Correct the parameters from "#3017 stapt1(Tap time constant (Gear: 00))" to "#3020 stapt4(Tap time constant (Gear: 11))".

Y51 Secondary axis No. illegal 0014

Details

In the axis synchronization, parameter settings for secondary axis differs from that of primary axis.

Remedy

- Correct the "#1068 slavno (secondary axis number)" setting.

Y51 Parameter skip_tL illegal 0015

Details

The time constant has exceeded the setting range.

Remedy

Correct "#2102 skip_tL (Skip time constant linear)".

Y51 Parameter skip_t1 illegal 0016

Details

The time constant has exceeded the setting range.

Remedy

Correct "#2103 skip_t1 (Skip time constant primary delay / Second-step time constant for soft acceleration/deceleration)".

Y51 Parameter G0bdcc illegal 0017

Details

"#1205 G0bdcc (Acceleration and deceleration before G0 interpolation)" for the 2nd part system is set to acceleration/deceleration before G0 interpolation.

Remedy

Correct "#1205 G0bdcc (Acceleration and deceleration before G0 interpolation)".

Y51 OMR-II parameter error 0018

Details

An illegal setting was found in the OMR-II-related parameters. OMR-II has been disabled.

Remedy

Correct the related parameter settings.

Y51 PLC indexing stroke length err 0019

Details

"#12804 aux_tleng (Linear axis stroke length)" has not been set or exceeded the setting range while the linear axis equal indexing is enabled for the PLC indexing axis.

Remedy

Correct "#12804 aux_tleng (Linear axis stroke length)".

Y51 No hi-accu acc/dec t-const ext 0020

Details

There is no expansion option for the high-accuracy acceleration/deceleration time constant.

Remedy

Set "#1207 G1btL (Time constant)" to a value within the setting range with no expansion specification for the extended high-accuracy time constant.

(Note) In the case of the system with two part systems, the expansion option for the high-accuracy acceleration /deceleration time constant cannot be enabled.

Y51 Superimpos linear G0 error 0022

Details

The time constant has not been set or exceeded the setting range.

Remedy

Check "#2092 pIG0tL G0 time constant for superimposition control (linear)".

Y51 Superimpos linear G1 error 0023

Details

The time constant has not been set or exceeded the setting range.

Remedy

Check "#2094 pIG1tL G1 time constant for superimposition control (linear)".

Y51 Parameter G0tL_2 illegal 0033

Details

The time constant is out of the specified range.

Remedy

Correct "#2598 G0tL_2 (G0 time constant 2 (linear))".

Y51 Parameter G0t1_2 illegal 0034

Details

The time constant is out of the specified range.

Remedy

Correct "#2599 G0t1_2 (G0 time constant 2 (primary delay)/Second-step time constant for soft acceleration/deceleration)".

Y51 Values of PC1/PC2 too large 0101

Details

The PC1 and PC2 settings for the rotary axis are too large.

Remedy

Correct "#2201 SV001 PC1 (Motor side gear ratio)" and "#2202 SV002 PC2 (Machine side gear ratio)".

Y90 No spindle signal 0001-0007

Details

There is an error in the spindle encoder signal.

The data transmission to the drive unit is stopped when this error occurs.

Remedy

Check the spindle encoder's feedback cable and the encoder.

Appendix 6.5 System Alarms (Z)

Z02 System error

Details

The operation result is illegal.

Remedy

- Contact the service center.

Z31 Socket open error(socket) 0001

Details

Socket open error (socket)

Remedy

Set the parameter then turn the power OFF and ON again.

Z31 Socket bind error(bind) 0002

Details

Socket bind error (bind)

Remedy

Set the parameter then turn the power OFF and ON again.

Z31 Connection wait queue error(listen) 0003

Details

Connection wait queue error (listen)

Remedy

Set the parameter then turn the power OFF and ON again.

Z31 Connection request error(accept) 0004

Details

Connection request error (accept)

Z31 Data rcv error(socket error) 0005

Details

Data receive error (socket error)

Z31 Data rcv error(data error) 0006

Details

Data receive error (data error)

Z31 Data send error(socket error) 0007

Details

Data send error (socket error)

Z31 Data send error(data error) 0008

Details

Data send error (data error)

Z31 Socket close error(close) 000A

Details

Socket close error (close)

Remedy

Set the parameter then turn the power OFF and ON again.

Z34 DeviceNet error**Details**

Any of the following errors has occurred in the DeviceNet unit.

- Master function error (X03 is ON)
- Slave function error (X08 is ON)
- Message communication error (X05 is ON)

If the errors have occurred in more than one unit, the error No. of the unit with the smallest slot No. is displayed.

If the master function, slave function and message communication errors have occurred at the same time, the error is displayed in the following priority order.

1. Master function error
2. Slave function error
3. Message communication error

Remedy

- Select the [Ext. PLC link control] menu on the maintenance screen to open the unit confirmation screen, and check the unit in error and details to cancel the error.
- For the details of the DeviceNet unit errors, refer to "External PLC Link II (Bus connection) MELSEC-Q Series Appendix 2 (DeviceNet)"BNP-C3039-276 (Appendix 2).

Z35 Direct Socket connection error 0001**Details**

- Connection has failed.
- Five or more clients attempted a connection.

Remedy

- Check the connection of the network cables, and check for broken wires and a failure of the network connection devices such as hub.
- When using the Direct Socket communication I/F, connect up to four clients.

Z35 Direct Socket receive error 0002**Details**

- Receiving data from a client has failed.

Remedy

- Check the connection of the network cables, and check for broken wires and a failure of the network connection devices such as hub.

Z35 Direct Socket send error 0003**Details**

- Sending data to a client has failed.

Remedy

- Check the connection of the network cables, and check for broken wires and a failure of the network connection devices such as hub.

Z35 Direct Socket timeout error 0004**Details**

There was no response from client computers, and a timeout error occurred.

Remedy

- Check the connection of the network cables, and check for broken wires and a failure of the network connection devices such as hub.

Z35 Direct Socket comm OFF 0005**Details**

The direct Socket communication I/F is OFF.

Remedy

- Check the parameter "#11051 Direct Socket OFF".

Z40 Format mismatch

Details

"#1052 MemVal (No. of common variables shared in part system designation)", formatted at "0", was set to "1".

Remedy

- Reset "#1052 MemVal (No. of common variables shared in part system designation)" to "0" or format and restart.

Z51 EEPROM ERROR

Details

The data read from EEPROM does not coincide with the data that has been written into it.

Remedy

- If the same alarm occurs with the same operation, a hardware fault may be the cause. Contact the service center.

Z52 Battery fault 000x

Details

The voltage of the battery in the NC control unit has dropped. (The battery used to save the internal data.)

0001: Battery warning
0002: Battery detecting circuit error
0003: Battery alarm

(Note)The display of "Z52 battery fault 0001" can be removed by resetting. However, the warning state will not be cleared until the battery is replaced.

Remedy

- Replace the battery of the NC control unit.
- Check for any disconnection of the battery cable.
- After fixing the battery's fault, check the machining program.

Z53 CNC overheat

Details

The controller or operation board temperature has risen above the designated value.

(Note)Temperature warning

When an overheat alarm is detected, the alarm is displayed and the overheat signal is output simultaneously. Automatic operation will be continued, while restarting after resetting or stopping with M02/M30 is not possible. (Restarting after block stop or feed hold is possible.) The alarm will be cleared and the overheat signal will turn OFF when the temperature drops below the specified temperature.

Z53 CNC overheat 000x
[000x]

(For all models)

0001: The temperature in the control unit is high.

(For M700VS only)

0004: The temperature in the control unit is high.

0005: The temperature in the control unit 2 is high.

The ambient temperature must be lowered immediately when a "Z53 CNC overheat" alarm occurs. However, if the machining needs to be continued, set "#6449/bit7 Control unit temperature alarm ON" to "0". Then the alarm will be invalidated.

Remedy

- Cooling measures are required.
- Turn OFF the controller power, or lower the temperature with a cooler, etc.

Z55 RIO communication stop

Details

An error occurs in the communication between the control unit and remote I/O unit.
 Disconnection of a cable
 Fault in remote I/O unit
 Fault of power supply to remote I/O unit
 The alarm and the I/O unit No. is displayed when an error occurs in the communication between the control unit and remote I/O unit.
 The remote I/O unit No. is displayed in eight digits. Two digits (in hexadecimal) are used for each board and part system.
 [Display format of remote I/O unit No.]

Z55 RIO communication stop $\overline{\text{(a)}} \overline{\text{(b)}} \overline{\text{(c)}} \overline{\text{(d)}} \overline{\text{(e)}} \overline{\text{(f)}} \overline{\text{(g)}} \overline{\text{(h)}}$

(a)(b): Remote I/O 2nd part system communication interrupted station
 (c)(d): Remote I/O 1st part system communication interrupted station
 (e)(f): Remote I/O 3rd part system communication interrupted station
 (g)(h): Board connection remote I/O communication interrupted station
 (a)(b) indicates the following station in hexadecimal.

- bit0: RIO (0th station)
- bit1: RIO (first station)
- bit2: RIO (second station)
- bit3: RIO (third station)
- bit4: RIO (fourth station)
- bit5: RIO (fifth station)
- bit6: RIO (sixth station)
- bit7: RIO (seventh station)

This also applies for the remote I/O 1st part system communication interrupted station, remote I/O 3rd part system communication interrupted station and board connection remote I/O communication interrupted station.

Remedy

- Check and replace the cables.
- Replace the remote I/O unit.
- Check the power supply (existence of supply and voltage).

Z57 System warning

Details

Program memory capacity has been set over the value that can be formatted.
 An expansion device/expansion cassette has not mounted after formatting.
 The mounted expansion device/expansion cassette is different from the one that was mounted at formatting.

Remedy

- Check the followings.
- Program memory capacity
 - Mounting of an expansion device/expansion cassette
 - APLC release option

Z58 ROM write not completed

Details

A machine tool builder macro program has not been written to FROM after being registered/ edited/ copied/ condensed/ merged/ the number changed/ deleted.

Remedy

- Write the machine tool builder macro program to FROM.
- The program does not need to be written to FROM unless the editing operations and so on need to be valid after the NC power OFF.

Z59 Acc/dec time cnst too large

Details

Acceleration and deceleration time constants are too large.
 (This alarm is output at the same time as "T02 0206".)

Remedy

- Set the larger value for "#1206 G1bF(Maximum speed)".
- Set the smaller value for "#1207 G1btL(Time constant)".
- Set the lower feedrate.

Z60 Fieldbus communication error n1 n2 n3 n4

Details

A communication error has occurred on the Fieldbus communication with HN571/HN573/HN575.
 [n1 :Shows state of the master channel (shown in hexadecimal number)]
 00 :Offline In initializing
 40 :Stop Cutting I/O communication
 80 :Clear Resetting output data of each slave by sending 0 data.
 C0 :In operation I/O In I/O communication
 [n2 :Shows error state (shown in hexadecimal number)]
 bit0 :Control error Parameter error
 bit1 :Auto clear error Communication with all the slave channels was cut because a communication with one slave channel had an error.
 bit2 :Non exchange error Slave channel with communication error is found.
 bit3 :Fatal error The communication cannot be continued because severe network failure exists.
 bit4 :Event error Short-circuit was found on the network.
 bit5 :Not ready CNC communication is not ready.
 bit6 :Time out error Time out was detected in communication with each channel.
 bit7 :Not used
 [n3 :Shows error No. (shown in hexadecimal number)]

- Error in master channel (when remote address with an error is FF (hexadecimal number))
 - 0 :No error Operating normally
 - 32 :No USR_INT Damage in HN571. Replace HN571.
 - 33 :No global data field
 - 34 :No FDL-task
 - 35 :No PLC-task
 - 37 :Master parameter incorrect
 - 39 :Slave parameter incorrect
 - 3C :Data offset exceeding allowable set value received. Check the configuration setting.
 - 3D :Slave data send range overlap
 - 3E :Slave data receive range overlap
 - 3F :Not set data hand shake Damage in HN571. Replace HN571.
 - 40 :RAM range exceeded
 - 41 :Slave parameter data set illegal
 - CA :No segment
 - D4 :Data base read illegal Download the configuration data again.
 - D5 :Operating system illegal Damage in HN571. Replace HN571.
 - DC :Watch dog error
 - DD :Hand shake mode No data communication by 0
 - DE :Master auto clear mode When setting auto clear mode, the auto clear mode was performed because one slave was not able to connect in run time.
- Error in slave channel (when remote address with an error is other than FF (hexadecimal number))
 Check the configuration of slave channel in which error has occurred. Check if there is any short-circuit in wire to bus.
 - 2 :Station overflow reported
 - 3 :Station stopped responding to master command
 - 9 :No slave required responding data
 - 11 :No station respond
 - 12 :No master to logical token ring
 - 15 :Illegal parameter requested

[n4 : Shows slave No. where communication error has occurred. (shown in hexadecimal number)]
 'FF' means an error in master channel.

Z64 Valid term soon to be expired xx

Details

The valid term will be expired in less than a week. Remaining valid term is xx days.

Remedy

- Obtain a decryption code from the machine tool builder and input it in the NC, then turn the power ON again.

Z65 Valid term has been expired

Details

The valid term has been expired with no decryption code input.

Remedy

- Obtain a decryption code from the machine tool builder and input it in the NC, then turn the power ON again.

Z67 CC-Link communication error**Details**

A communication error occurred during CC-Link communication using CC-Link unit.

Remedy

- Refer to "List of Messages" in CC-Link (Master/Slave) Specification manual (BNP-C3039-214).

Z68 CC-Link unconnected**Details**

A cable between CC-Link unit and a device is disconnected or broken.

Remedy

- Connect the cable.
- Check for any broken cables.

Z69 External link error 2**Details**

A FROM/TO instruction was used while the MELSEC-Q interface expansion module is not installed.

Remedy

Install the MELSEC-Q interface expansion module.

Z69 External link error 3**Details**

A negative value was set for an I/O No. in the FROM/TO instruction.

Remedy

Correct the I/O No.

Z69 External link error 4**Details**

A negative value was set for transfer size in the FROM/TO instruction.

Remedy

Correct the transfer size.

Z69 External link error 5**Details**

The number of FROM/TO instructions within one scan has exceeded 50.

Remedy

Correct the user PLC (ladder sequence) so that the number of FROM/TO instructions per scan is 50 or less.

Z69 External link error 6**Details**

The access to the buffer memory by the FROM/TO instruction has exceeded 12K words per scan.

Remedy

Correct the user PLC (ladder sequence) so that the buffer memory access by the FROM/TO instruction won't exceed 12K words per scan. (The total size of FROM/TO is up to 12K words.)

Z69 External link error 7**Details**

A FROM/TO instruction was used in high-speed processing.

Remedy

Delete the FROM/TO instruction from high-speed processing.

Z69 External link error 8**Details**

The bit device number designated in the FROM/TO instruction is not a multiple of 16.

Remedy

Correct the bit device number designated in the FROM/TO instruction to be a multiple of 16.

Z69 External link error 9

Details

With a FROM/TO instruction, a value out of the address range (negative value, or 0x8000 or over) was set as the head address of the buffer memory.

Remedy

Correct the head address of the buffer memory.

Z69 External link error 10

Details

An alarm occurred in the MELSEC module mounted on the extension base.

Remedy

Check for any disconnection of the MELSEC module and the cables on the extension base. Then turn the CNC's power ON again.

Z69 External link error 11

Details

The I/O No. designated in the FROM/TO instruction is different from the mounted location of the intelligent function module on the extension base (the module's I/O No.).

Remedy

Correct the I/O No. Then turn the CNC's power ON again.

Z82 3D machine interference/No machine model 0001

Details

Machine model is not registered.

Remedy

- Press RESET to cancel the alarm.
Movement can be resumed after the cancellation. However, the 3D machine interference check will become invalid.
- Inform the machine tool builder if an alarm occurs.

Z82 3D machine interference/Machine model illegal 0002

Details

Machine model is illegal.

Remedy

- Press RESET to cancel the alarm.
Movement can be resumed after the cancellation. However, the 3D machine interference check will become invalid.
- Inform the machine tool builder if an alarm occurs.

Z82 3D machine Interference check load excess 003

Details

The calculation of the interference check took time and caused a deceleration.

Remedy

- Inform the machine tool builder.
- Restart the axis in case of a manual operation.
- In case of an automatic operation, the operation will automatically resume when the processing load of the interference check decreases.

Z82 3D machine Interference check error 004

Details

The interference check failed.

Remedy

- Take a note of the failed status and contact the service center.
- Press RESET to cancel the alarm. Invalidate the 3D machine interference check to continue the operation.

Z83 NC started during SP rotation 0001

Details

The NC was started while the spindle was rotating.

Remedy

Turn the power OFF and confirm that the spindle is not rotating, then turn the power ON again.

Appendix 6.6 Absolute Position Detection System Alarms (Z7*)

Z70 Abs posn base set incomplete 0001 (Axis name)

Details

Zero point initialization is incomplete. Otherwise, the spindle was removed.

Remedy

Complete zero point initialization.

(Note) To release alarm "Z70 Abs data error", enter the parameter data output when establishing the absolute position and turn ON the power again. For the rotary axis, however, the alarm cannot be released by entering the parameter data.

- Zero point initialization: Required

Z70 Absolute position lost 0002 (Axis name)

Details

The absolute position basic point data saved in the NC has been damaged.

Remedy

Set the parameters. If the basic point data is not restored by setting the parameters, perform zero point initialization.

(Note) To release alarm "Z70 Abs data error", enter the parameter data output when establishing the absolute position and turn ON the power again. For the rotary axis, however, the alarm cannot be released by entering the parameter data.

- Zero point initialization: (Required)

Z70 Abs posn param changed 0003 (Axis name)

Details

Any of the parameters for absolute position detection has been changed.

#1003 iunit

#1016 iout

#1017 rot

#1018 ccw

#1040 M_inch

#2049 type

Remedy

Correct the parameter settings. Then turn the power ON again and perform zero point initialization.

(Note) To release alarm "Z70 Abs data error", enter the parameter data output when establishing the absolute position and turn ON the power again. For the rotary axis, however, the alarm cannot be released by entering the parameter data.

- Zero point initialization: Required

Z70 Abs posn initial set illegal 0004 (Axis name)

Details

The zero point initialization point is not at the grid position.

Remedy

Perform the zero point initialization again.

(Note) To release alarm "Z70 Abs data error", enter the parameter data output when establishing the absolute position and turn ON the power again. For the rotary axis, however, the alarm cannot be released by entering the parameter data.

- Zero point initialization: Required

Z70 Abs posn param restored 0005 (Axis name)

Details

The data has been restored by inputting the parameters during the alarm No.0002.

Remedy

Turn the power ON again to start the operation.

(Note) To release alarm "Z70 Abs data error", enter the parameter data output when establishing the absolute position and turn ON the power again. For the rotary axis, however, the alarm cannot be released by entering the parameter data.

- Zero point initialization: Not required

Z70 Abs data error 0006

Details

Deviation of the servo axis with scale when the power is OFF exceeds the set value in "#2051 check (Check)".

Remedy

- Search for the factor which led the deviation of the servo axis at the power OFF.
- Zero point initialization: Not required
- Alarm reset when power is turned OFF: -
- Servo alarm No.: -

Z70 Abs posn data lost 0080 (Axis name)

Details

The absolute position data has been lost. An error of the multi-rotation counter data in the detector and so on may be the cause.

Remedy

- Replace the detector and complete zero point initialization.
- (Note) To release alarm "Z70 Abs data error", enter the parameter data output when establishing the absolute position and turn ON the power again. For the rotary axis, however, the alarm cannot be released by entering the parameter data.
- Zero point initialization: Required
- Servo alarm No.: (9E)etc.

Z70 Abs posn error(servo alm 25) 0101 (Axis name)

Details

The servo alarm No. 25 was displayed and the power was turned ON again.

Remedy

- Perform zero point initialization again.
- (Note) To release alarm "Z70 Abs data error", enter the parameter data output when establishing the absolute position and turn ON the power again. For the rotary axis, however, the alarm cannot be released by entering the parameter data.
- Zero point initialization: Required
- Servo alarm No.: -25

Z70 Abs posn error(servo alm E3) 0106 (Axis name)

Details

The servo alarm No. E3 was displayed and the power was turned ON again.

Remedy

- Perform zero point initialization again.
- (Note) To release alarm "Z70 Abs data error", enter the parameter data output when establishing the absolute position and turn ON the power again. For the rotary axis, however, the alarm cannot be released by entering the parameter data.
- Zero point initialization: Required
- Servo alarm No.: (E3)

Z71 AbsEncoder:Backup voltage drop 0001 (Axis name)

Details

Backup voltage in the absolute position detector dropped.

Remedy

- Replace the battery, check the cable connections, and check the detector. Turn the power ON again and perform zero point initialization.
- Zero point initialization: Required
- Alarm reset when power is turned OFF: -(Z70-0101 is displayed after the power is turned ON again.)
- Servo alarm No.: 25

Z71 AbsEncoder: Commu error 0003 (Axis name)**Details**

Communication with the absolute position detector has been disabled.

Remedy

Check and replace the cables, card or detector. Turn the power ON again and perform zero point initialization.

- Zero point initialization: (Required) only when the detector has been replaced.
- Alarm reset when power is turned OFF: Reset
- Servo alarm No.: 91

Z71 AbsEncoder: Abs data changed 0004 (Axis name)**Details**

Absolute position data has been changed at the absolute position establishment.

Remedy

Check and replace the cables, card or detector. Turn the power ON again and perform zero point initialization.

- Zero point initialization: (Required) only when the detector has been replaced.
- Alarm reset when power is turned OFF: Reset
- Servo alarm No.: 93

Z71 AbsEncoder: Serial data error 0005 (Axis name)**Details**

An error of the serial data was found in the absolute position detector.

Remedy

Check and replace the cables, card or detector. Turn the power ON again and perform zero point initialization.

- Zero point initialization: (Required) only when the detector has been replaced.
- Alarm reset when power is turned OFF: Reset
- Servo alarm No.: 92

Z71 AbsEncoder: Abs/inc posn diffr 0006 (Axis name)**Details**

Servo alarm E3
Absolute position counter warning

Remedy

Operation is possible until the power is turned OFF.

- Zero point initialization: (Required) after the power is turned ON again.
- Alarm reset when power is turned OFF: Reset (Z70-0106 is displayed after the power is turned ON again.)
- Servo alarm No.: E3

Z71 AbsEncoder: Initial commu er 0007 (Axis name)**Details**

Initial communication with the absolute position detector is not possible.

Remedy

Check and replace the cables, card or detector. Turn the power ON again and perform zero point initialization.

- Zero point initialization: (Required) only when the detector has been replaced.
- Alarm reset when power is turned OFF: Reset
- Servo alarm No.: 18

Z72 Message: Position check error (Axis name)**Details**

An error is detected at the comparison of detector's absolute position and controller coordinate values in the absolute position detection system.

Remedy

Z73 Battery for abs data fault 0001**Details**

Low backup battery
Servo alarm 9F
Low battery voltage

Remedy

This is displayed when the battery voltage is 0 low or the cable has been damaged.
The absolute position initialization is not required.

(Note) When this alarm has occurred, do not turn OFF the drive unit power in order to protect the absolute position data. Replace the battery with the drive unit power ON.

Appendix 6.7 Distance-coded Reference Scale Errors (Z8*)

Z80 Basic position lost 0001

Details

The basic point data saved in the NC has been damaged.

Remedy

- Set the parameters. If the basic point data is not restored by setting the parameters, perform zero point initialization.

Z80 Basic position restore 0002

Details

The basic point data has been restored by setting the parameters.

Remedy

- Turn the power ON again to start the operation.

Z80 No spec: Distance-coded scale 0003

Details

The distance-coded reference scale has been set available although this function is out of the specifications.

Remedy

- Check the specifications.
- If you do not use this function, correct the detector type with the servo parameter.

Z81 R-pos adjustment data lost 0001

Details

Reference position adjustment value data saved in the NC has been damaged.

Remedy

- Set the parameter. If the data is not restored by setting the parameter, establish the reference position again.

Z81 R-pos adjustment data restored 0002

Details

After the 'Z81 R-pos adjustment data lost 0001', the data has been recovered by setting the parameter.

Remedy

- Establish the reference position to start the operation.

Appendix 6.8 Emergency Stop Alarms (EMG)

EMG Emergency stop PLC

Details

The user PLC has entered the emergency stop state during the sequence process.

Remedy

- Investigate and remove the cause of the user PLC emergency stop.

EMG Emergency stop EXIN

Details

The "emergency stop" signal is significant (open).

Remedy

- Cancel the "emergency stop" signal.
- Check for any broken wires.

EMG Emergency stop SRV

Details

An alarm occurred in the servo system causing an emergency stop.

Remedy

- Investigate and remove the cause of the servo alarm.

EMG Emergency stop STOP

Details

The user PLC (ladder sequence) is not running.

Remedy

- Check the setting of the control unit rotary switch CS2. Correct it if set to "1".
- Check the [RUN/SP] (run/stop) switch on the PLC edit file save screen (onboard function). Turn it OFF if ON.

EMG Emergency stop SPIN

Details

Spindle drive unit is not mounted.

Remedy

- Cancel the causes of the other emergency stop.
- Check the "emergency stop" signal input in the spindle drive unit.

EMG Emergency stop PC_H

Details

Failure in the high-speed PC processing abnormal

Remedy

- Correct the sequence program. (To stop monitoring the high-speed PC processing temporarily, set "1" in "#1219 aux03/bit1 (Stop high-speed PC monitoring function)". Disable the monitoring function only as a temporary measure.)

EMG Emergency stop PARA

Details

Setting of the door open II fixed device is illegal.

Setting of the parameters for dog signal random assignment is illegal.

Remedy

- Correct the "#1155 DOOR_m" and "#1156 DOOR_s" settings. (When the door open II fixed device is not used, set "#1155 DOOR_m" and "#1156 DOOR_s" to "100".)
- Correct the "#2073 zrn_dog (Origin dog Random assignment device)", "#2074 H/W_OT+ (H/W OT+ Random assignment device)", "#2075 H/W_OT- (H/W OT- Random assignment device)" and "#1226 aux10/bit5 (Arbitrary allocation of dog signal)" settings.

EMG Emergency stop LINK

Details

An emergency stop occurs when the FROM/TO instruction is not executed within 500ms.

Remedy

- Execute the FROM/TO instruction one or more times every 500ms.

The time in which no interrupt request is issued from MELSEC is measured and stored in the following R registers:

R10190: Current timeout counter

R10191: Maximum timeout counter after power ON

R10192: Maximum timeout counter after system is started up (this is backed up)

Details

MELSEC is in error and reset states.

Remedy

- Check the MELSEC states.

Details

The contents of MELSEC-specific code area in buffer memory have been damaged.

Remedy

- Check the MELSEC states.

Details

PLC serial link communication has stopped.

(Note) When "WAIT" is entered in the PLC serial link, only the preparation sequence has been established before the communication stops. It is supposed that the settings of the serial link parameters "#1902 Din size" and "#1903 Dout size" are incorrect or the "#1909 Tout (ini)" set-time is too short in basic specification parameters.

Remedy

- Check the CC-Link card wiring and the external sequencer transmission.
- Check the link communication errors shown on the diagnostic screen.
- Correct the settings of the serial link parameters in basic specification parameters.

EMG Emergency stop WAIT

Details

The preparation sequence is not sent from the master station. Otherwise, the contents of the received preparation sequence are inconsistent with those of the parameters, so that the usual sequence cannot be started.

(Note) When "LINK" is also entered for the PLC serial link, refer to "Note" in the section, "LINK".

Remedy

- Check that the CC-Link card switch setting and wiring as well as the external sequencer transmission are normal.
- Check the diagnostic screen for link communication errors.

EMG Emergency stop XTEN

Details

The CC-Link card is operating incorrectly.

Switch/parameter settings for the CC-Link card are incorrect.

Remedy

- Replace the CC-Link card.
- Correct the switch/parameter settings for the CC-Link card.

EMG Emergency stop LAD

Details

The sequence program has an illegal code.

Remedy

- Correct any illegal device Nos. or constants in the sequence program.

EMG Emergency stop CVIN

Details

The "emergency stop" signal for power supply is significant (open) because the external emergency stop function for power supply is enabled.

Remedy

- Cancel the "emergency stop" signal.
- Check for any broken wires.
- Make sure that NC reset 1 signal, NC rest 2 signal, and reset & rewind signal are all OFF. (All part systems must be OFF on a multi-part system machine.)

EMG Emergency stop MCT

Details

The contactor shutoff test is being executed.

Remedy

- The emergency stop is reset automatically after the contactor shutoff is confirmed.
- If the contactor shutoff is not confirmed within 5 seconds after the "contactor shutoff test" signal has been input, the "contactor welding detected" alarm occurs and the emergency stop status remains.
- Make sure that the contactor's auxiliary B contact signal is correctly output to the device that is set in "#1330 MC_dp1" and "#1331 MC_dp2" (Contactor weld detection device 1 and 2), and then turn the power ON again.

EMG Emergency stop IPWD

Details

The data backup for power failure might not have been executed successfully at the previous power failure.

Remedy

- If this message appears frequently, the power supply may be deteriorated. Contact the service center.

EMG Emergency stop SUIN

Details

The emergency stop input signal (M0) is OFF in the NC/PLC safety circuit.

Remedy

- Check the conditions for turning ON the emergency stop input signal.
- Check for any broken wires.

EMG Emergency stop STP2

Details

Sequence programs stopped in CNC.

Remedy

- Correct the rotary switch 1 (on the right) of the control unit if set to "1".

EMG Emergency stop MULT

Details

An error related to Q bus or Qr bus occurred.

Remedy

- Refer to the error No. that follows the message "A01 Multi CPU error" to take a remedy.

EMG Emergency stop LINE

Details

An error was detected when communicating with the drive unit.

Remedy

- Check the wiring.

Appendix 6.9 Computer Link Errors (L)

L01 Serial port being used -2

Details

Serial port has already been opened or cannot be used.

Remedy

- Set the port not to shared by Anshin-net and so on.
- Correct the parameter settings for tape operation port.

L01 Timeout error -4

Details

Communication ended with timeout.
(CNC has a 248-byte receive buffer. The time during which CNC receives 248 bytes exceeds the 'TIME-OUT' value set in the I/O device parameter.)

Remedy

- Set a greater timeout value in the input/output device parameter.
- Check the software in HOST and make sure that the HOST transmits data in response to DC1(data request) from CNC.
- Set '#9614 START CODE' to '0'.

L01 Host ER signal OFF -10

Details

ER signal in HOST (or DR signal in CNC) is not turned ON.

Remedy

- Check for any disconnected cable.
- Check for any broke wire.
- Make sure that the HOST power is turned ON.

L01 Parity H error -15

Details

Communication ended with parity H.

Remedy

- Check the software in HOST and make sure that the data to be transmitted to CNC is ISO code.

L01 Parity V error -16

Details

Communication ended with parity V.

Remedy

- Correct the data to transmit to CNC.

L01 Overrun error -17

Details

CNC received 10 bytes or more data from HOST in spite of DC3 (request to stop data transfer) transmission from CNC to the HOST, which terminated the communication.
CNC received 10 bytes or more data from HOST during the data transmission from CNC to the HOST.

Remedy

- Check the software in HOST and make sure that the HOST stops transmitting data within 10 bytes after receiving DC3.
- Correct the software in HOST not to transmit data such as a command or header to CNC during receiving a machining program.

Appendix 6.10 User PLC Alarms (U)

(Note) For details of user PLC alarms (U), refer to the PLC Programming Manual.

U01 No user PLC - -

Details

PLC program is not input.

(Note 1) The number of PLC program steps displayed on the screen may not match the actual number of error occurrence steps because of the PLC program timing. Use this as a guideline of the occurrence place.

(Note 2) Emergency stop (EMG) will be applied.

Remedy

Download the PLC program with the format selected by the PLC environment selection parameters (bit selection "#51/bit4").

U10 Illegal PLC 0x0010 -

Details

PLC scan time error

The scan time is 1 second or longer.

(Note) The number of PLC program steps displayed on the screen may not match the actual number of error occurrence steps because of the PLC program timing. Use this as a guideline of the occurrence place.

Remedy

Edit the PLC program to make the size smaller.

U10 Illegal PLC 0x0040 -

Details

PLC program operation mode illegal

The downloaded PLC program is compatible with the designated mode.

(Note 1) The number of PLC program steps displayed on the screen may not match the actual number of error occurrence steps because of the PLC program timing. Use this as a guideline of the occurrence place.

(Note 2) Emergency stop (EMG) will be applied.

Remedy

Turn the power ON again or download the PLC program with the same format as at the power ON.

U10 Illegal PLC 0x0080 -

Details

GPPW ladder code error

(Note 1) The number of PLC program steps displayed on the screen may not match the actual number of error occurrence steps because of the PLC program timing. Use this as a guideline of the occurrence place.

(Note 2) Emergency stop (EMG) will be applied.

Remedy

Download the PLC program with a correct GPPW format.

U10 Illegal PLC 0x008x -

Details

PLC4B ladder code error

An illegal circuit was found in the PLC4B ladder.

bit1: PC medium-speed circuit illegal

bit2: PC high-speed circuit illegal

(Note 1) The number of PLC program steps displayed on the screen may not match the actual number of error occurrence steps because of the PLC program timing. Use this as a guideline of the occurrence place.

(Note 2) Emergency stop (EMG) will be applied.

Remedy

Download the correct PLC4B format PLC program.

U10 Illegal PLC 0x0400 Number of ladder steps

Details

Software illegal interrupt

An abnormal stop occurred in the PLC program process due to an illegal code for software command.

(Note 1) The number of PLC program steps displayed on the screen may not match the actual number of error occurrence steps because of the PLC program timing. Use this as a guideline of the occurrence place.

(Note 2) Emergency stop (EMG) will be applied.

Remedy

Turn the power ON again.

If the error is not reset, download the correct PLC program.

U10 Illegal PLC 0x800x Number of PLC program steps

Details

Software exception

An abnormal stop occurred in PLC program process due to a bus error, etc.

bit0: BIN command operation error

bit1: BCD command operation error

(Note) The number of PLC program steps displayed on the screen may not match the actual number of error occurrence steps because of the PLC program timing. Use this as a guideline of the occurrence place.

Remedy

Refer to the methods for using the BCD and BIN function commands.

Details

Software exception

An abnormal stop occurred in PLC program process due to a bus error, etc.

bit6: CALL/CALLS/RET command error

bit7: IRET command execution error

(Note 1) The number of PLC program steps displayed on the screen may not match the actual number of error occurrence steps because of the PLC program timing. Use this as a guideline of the occurrence place.

(Note 2) Emergency stop (EMG) is applied for bit6/7.

Remedy

Turn the power ON again.

If the error is not reset, download the correct PLC program.

U50 PLC stopped

Details

The PLC program is stopped.

(Note) The number of PLC program steps displayed on the screen may not match the actual number of error occurrence steps because of the PLC program timing. Use this as a guideline of the occurrence place.

Remedy

Start the PLC program.

U55 PLC stopped / is not saved

Details

The PLC program is stopped and not written into ROM.

(Note) The number of PLC program steps displayed on the screen may not match the actual number of error occurrence steps because of the PLC program timing. Use this as a guideline of the occurrence place.

Remedy

Write the PLC program into ROM.

U60 Ladder is not saved**Details**

The PLC program is not written into ROM.

(Note) The number of PLC program steps displayed on the screen may not match the actual number of error occurrence steps because of the PLC program timing. Use this as a guideline of the occurrence place.

Remedy

Write the PLC program into ROM.

Appendix 6.11 Network Service Errors (N)

N001 Modem initial error

Details

An error occurred in the modem connection at the power ON.

Remedy

- Check the connection between the NC and modem, connection port and power supply to modem.

N002 Redial over

Details

- The number of redials exceeded due to the dial transmission failure.

Remedy

- Wait a while, and then dial again.

N003 TEL unconnect

Details

- The phone line is not connected.

Remedy

- Check for any disconnection in the modem's phone line.

N004 Net communication error

Details

- An error other than the above occurred during communication.

Remedy

- Note down how the error occurred and contact the service center.

N005 Invalid net communication

Details

- The modem connection port is being used for another function such as input/output.
- The modem connection port settings are incorrect.

Remedy

- Stop using the modem connection port with the other function, and then turn the power ON again.
- Correct the settings of the modem connection port.

N006 Received result of diagnosis

Details

- A diagnosis data file has been received.

Remedy

- Clear the message.

N007 Send data size over

Details

- A file larger than Anshin-net server capacity (64Kbyte) has been transmitted in machining data sharing.

Remedy

- Reduce the size of machining program file so that it won't exceed the capacity of Anshin-net server.

N008 No file on server

Details

- The file reception failed in machining data sharing because no file exists on Anshin-net server.

Remedy

- Confirm that a machining program file exists on Anshin-net server before receiving it.

N009 Password error**Details**

- The file reception failed in machining data sharing due to a wrong password.

Remedy

- Input the password again.

N010 Customer number error**Details**

- The file reception failed in machining data sharing due to a wrong customer number.

Remedy

- Input the customer number again.

N011 Storage capacity over**Details**

- The file reception failed in machining data sharing because the size of the file to be received is bigger than free space in the NC.

Remedy

- Ensure sufficient free space in the NC.

N012 File deletion error**Details**

- A file on Anshin-net server cannot be deleted in machining data sharing.

Remedy

- Confirm that the file exists on Anshin-net server.
- Note down how the error occurred and contact the service center.

Appendix 6.12 Program Errors (P)

P10 No. of simultaneous axes over

Details

The number of axis addresses commanded in a block exceeds the specifications.

Remedy

- Divide the alarm block command into two.
- Check the specifications.

P11 Illegal axis address

Details

The axis address commanded by the program does not match any of the ones set by the parameter.

Remedy

- Correct the axis names in the program.

P20 Division error

Details

The issued axis command cannot be divided by the command unit.

Remedy

- Correct the program.

P29 Not accept command

Details

The command has been issued when it is impossible.

- The normal line control command (G40.1, G41.1, G42.1) has been issued during the modal in which the normal line control is not acceptable.
- The command has been issued during the modal in which the 2-part system synchronous thread cutting is not acceptable.

Remedy

- Correct the program.

P30 Parity H error

Details

The number of holes per character on the paper tape is even for EIA code and odd for ISO code.

Remedy

- Check the paper tape.
- Check the tape puncher and tape reader.

P31 Parity V error

Details

The number of characters per block on the paper tape is odd.

Remedy

- Make the number of characters per block on the paper tape even.
- Set the parameter parity V selection OFF.

P32 Illegal address

Details

An address not listed in the specifications has been used.

Remedy

- Correct the program address.
- Correct the parameter settings.
- Check the specifications.

P33 Format error

Details

The command format in the program is not correct.

Remedy

- Correct the program.

P34 Illegal G code**Details**

The commanded G code is not in the specifications.
An illegal G code was commanded during the coordinate rotation command.

Remedy

- Correct the G code address in the program.

Details

G51.2 or G50.2 was commanded when "#1501 polyax (Rotational tool axis number)" was set to "0".
G51.2 or G50.2 was commanded when the tool axis was set to the linear axis ("#1017 rot (Rotational axis)" is set to "0").

Remedy

- Correct the parameter settings.

P35 Setting value range over**Details**

The setting range for the addresses has been exceeded.

Remedy

- Correct the program.

P36 Program end error**Details**

"EOR" has been read during tape and memory mode.

Remedy

- Enter the M02 and M30 command at the end of the program.
- Enter the M99 command at the end of the subprogram.

P37 O, N number zero**Details**

"0" has been specified for program or sequence No.

Remedy

- Designate program Nos. within a range from 1 to 99999999.
- Designate sequence Nos. within a range from 1 to 99999.

P38 No spec: Add. Op block skip**Details**

"/n" has been issued while the optional block skip addition is not in the specifications.

Remedy

- Check the specifications.

P39 No specifications**Details**

- A non-specified G code was commanded.
- The selected operation mode is out of specifications.

Remedy

- Check the specifications.

P45 G-CODE COMB.**Details**

The combination of G codes in a block is inappropriate.
A part of unmodal G codes and modal G codes cannot be commanded in a same block.

Remedy

Correct the combination of G codes.
Separate the incompatible G codes into different blocks.

P48 Restart pos return incomplete

Details

A travel command was issued before the execution of the block that had been restart-searched.

Remedy

- Carry out program restart again.
Travel command cannot be executed before the execution of the block that has been restart-searched.

P49 Invalid restart search

Details

- Restart search was attempted for the 3-dimensional circular interpolation.
- Restart search was attempted for the mixed control (cross axis control) command (G110).
- Restart search was attempted during the cylindrical interpolation, polar coordinate interpolation, or tool tip center control.
- Restart search was attempted from a block (G68.2) during the inclined surface machining mode or from the inclined surface machining mode cancel command block (G69).
- Restart search was attempted to the program after direct command mode.

Remedy

- Correct the program.
- Correct the restart search position.

P50 No spec: Inch/Metric change

Details

Inch/Metric changeover (G20/G21) command was issued while the function is out of specifications.

Remedy

- Check the specifications.

P60 Compensation length over

Details

The commanded movement distance is excessive (over 2^{31}).

Remedy

- Correct the command range for the axis address.

P61 No spec: Unidirectional posit.

Details

Unidirectional positioning (G60) was commanded while the function is out of specifications.

Remedy

- Check the specifications.

P62 No F command

Details

- No feed rate command has been issued.
- There is no F command in the cylindrical interpolation or polar coordinate interpolation immediately after the G95 mode is commanded.

Remedy

- The default movement modal command at power ON is G01. This causes the machine to move without a G01 command if a movement command is issued in the program, and an alarm results. Use an F command to specify the feed rate.
- Specify F with a thread lead command.

P63 No spec: High-speed machining

Details

High-speed machining cancel (G5P0) was commanded while the high-speed machining is out of specifications.

Remedy

- Check the specifications.

P65 No spec: High speed mode 3

Details

Remedy

- Check whether the specifications are provided for the high-speed mode III.

P70 Arc end point deviation large

Details

- There is an error in the arc start and end points as well as in the arc center.
- The difference of the involute curve through the start point and the end point is large.
- When arc was commanded, one of the two axes configuring the arc plane was a scaling valid axis.

Remedy

- Correct the numerical values of the addresses that specify the start and end points, arc center as well as the radius in the program.
- Correct the "+" and "-" directions of the address numerical values.
- Check for the scaling valid axis.

P71 Arc center error

Details

- An arc center cannot be obtained in R-specified circular interpolation.
- A curvature center of the involute curve cannot be obtained.

Remedy

- Correct the numerical values of the addresses in the program.
- Correct the start and end points if they are inside of the base circle for involute interpolation. When carrying out tool radius compensation, make sure that the start and end points after compensation will not be inside of the base circle for involute interpolation.
- Correct the start and end points if they are at an even distance from the center of the base circle for involute interpolation.

P72 No spec: Helical cutting

Details

A helical command has been issued though it is out of specifications.

Remedy

- Check whether the specifications are provided for the helical cutting.
- An Axis 3 command has been issued by the circular interpolation command. If there is no helical specification, move the linear axis to the next block.

P73 No spec: Spiral cutting

Details

A spiral command was issued though it is out of specifications.

Remedy

- Issue the G02.1 and G03.1 commands for circular interpolation.
- Check whether the specifications are provided for the spiral cutting.

P74 Can't calculate 3DIM arc

Details

The 3-dimension circular cannot be obtained because the end block was not specified during 3-dimension circular interpolation supplementary modal.

The 3-dimension circular cannot be obtained due to an interruption during 3-dimension circular interpolation supplementary modal.

Remedy

- Correct the program.

P75 3DIM arc illegal

Details

An illegal G code was issued during 3-dimension circular interpolation modal.

Otherwise, 3-dimension circular interpolation command was issued during a modal for which a 3-dimension circular interpolation command cannot be issued.

Remedy

- Correct the program.

P76 No spec: 3DIM arc interpolat

Details

G02.4/G03.4 was commanded though there is no 3-dimension circular interpolation specification.

Remedy

- Check the specifications.

P80 No spec: Hypoth ax interpolat

Details

Hypothetical axis interpolation (G07) was commanded though it is out of specifications.

Remedy

- Check the specifications.

P90 No spec: Thread cutting

Details

A thread cutting command was issued though it is out of specifications.

Remedy

- Check the specifications.

P91 No spec: Var lead threading

Details

Variable lead thread cutting (G34) was commanded though it is out of specifications.

Remedy

- Check the specifications.

P93 Illegal pitch vaule

Details

An illegal thread lead (thread pitch) was specified at the thread cutting command.

Remedy

- Correct the thread lead for the thread cutting command.

P100 No spec: Cylindric interpolat

Details

A cylindrical interpolation command was issued though it is out of specifications.

Remedy

- Check the specifications.

P110 Plane select during figure rot

Details

Plane selection (G17/G18/G19) was commanded during figure rotation.

Remedy

- Correct the machining program.

P111 Plane selected while coord rot

Details

Plane selection commands (G17, G18, G19) were issued during a coordinate rotation was being commanded.

Remedy

- Always command coordinate rotation cancel after the coordinate rotation command, and then issue a plane selection command.

P112 Plane selected while R compen

Details

- Plane selection commands (G17, G18, G19) were issued while tool radius compensation (G41, G42) and nose R compensation (G41, G42, G46) commands were being issued.
- Plane selection commands were issued after completing nose R compensation commands when there were no further axis movement commands after G40, and compensation has not been cancelled.

Remedy

- Issue plane selection commands after completing (axis movement commands issued after G40 cancel command) tool radius compensation and nose R compensation commands.

P113 Illegal plane select

Details

The circular command axis does not correspond to the selected plane.

Remedy

- Select a correct plane before issuing a circular command.

P120 No spec: Feed per rotation

Details

Feed per rotation (G95) was commanded though it is out of specifications.

Remedy

- Check the specifications.

P121 F0 command during arc modal

Details

F0 (F 1-digit feed) was commanded during the arc modal (G02/G03).

Remedy

- Correct the machining program.

P122 No spec: Auto corner override

Details

An auto corner override command (G62) was issued though it is out of specifications.

Remedy

- Check the specifications.
- Delete the G62 command from the program.

P123 No spec: High-accuracy control

Details

High-accuracy control command was issued though it is out of specifications.

Remedy

- Check the specifications.

P124 No spec: Inverse time feed

Details

- The inverse time option is not provided.

Remedy

- Check the specifications.

P125 G93 mode error

Details

- The issued G code command is illegal during G93 mode.
- G93 command was issued during a modal for which inverse time feed cannot be performed.

Remedy

- Correct the program.

P126 Invalid cmdn in high-accuracy

Details

An illegal command was issued during the high-accuracy control mode.

- A G code group 13 command was issued during the high-accuracy control mode.
- Milling, cylindrical interpolation or pole coordinate interpolation was commanded during the high-accuracy control mode.

Remedy

- Correct the program.

P127 No spec: SSS Control

Details

The SSS control valid parameter has been set although there is no SSS control specification.

Remedy

- Check the specifications. Set "#8090 SSS ON" to "0" when there is no SSS control specification.

P128 Machin condtn select I disable

Details

Machining condition selection I was commanded during the mode where the selection command is unavailable.

Remedy

- Check the program and see whether any unavailable mode is included during machining condition selection I. If any, cancel that mode.

P130 2nd M function code illegal

Details

The 2nd miscellaneous function address, commanded in the program, differs from the address set in the parameters.

Remedy

- Correct the 2nd miscellaneous function address in the program.

P131 No spec: Cnst surface ctrl G96

Details

A constant surface speed control command (G96) was issued though it is out of specifications.

Remedy

- Check the specifications.
- Issue a rotation speed command (G97) instead of the constant surface speed control command (G96).

P132 Spindle rotation speed S=0

Details

No spindle rotation speed command has been issued.

Remedy

- Correct the program.

P133 Illegal P-No. G96

Details

The illegal No. was specified for the constant surface speed control axis.

Remedy

- Correct the parameter settings and program that specify the constant surface speed control axis.

P134 G96 Clamp Err.

Details

The constant surface speed control command (G96) was issued without commanding the spindle speed clamp (G92/G50).

Remedy

Press the reset key and carry out the remedy below.

- Check the program.
- Issue the G92/G50 command before the G96 command.
- Command the constant surface speed cancel (G97) to switch to the rotation speed command.

P140 No spec: Pos compen cmd

Details

The position compensation command (G45 to G48) is out of specifications.

Remedy

- Check the specifications.

P141 Pos compen during rotation

Details

Position compensation was commanded during the figure rotation or coordinate rotation command.

Remedy

- Correct the program.

P142 Pos compen invalid arc

Details

Position compensation cannot be executed with the issued arc command.

Remedy

- Correct the program.

P150 No spec: Nose R compensation

Details

- Tool radius compensation commands (G41 and G42) were issued though they are out of specifications.
- Nose R compensation commands (G41, G42, and G46) were issued though they are out of specifications.

Remedy

- Check the specifications.

P151 Radius compen during arc mode

Details

A compensation command (G40, G41, G42, G43, G44, or G46) has been issued in the arc modal (G02 or G03).

Remedy

- Issue the linear command (G01) or rapid traverse command (G00) in the compensation command block or cancel block.
(Set the modal to linear interpolation.)

P152 No intersection

Details

- In interference block processing during execution of a tool radius compensation (G41 or G42) or nose R compensation (G41, G42, or G46) command, the intersection point after one block is skipped cannot be determined.
- The compensation amount cannot be calculated during the tool radius compensation for 5-axis machining (G41.2,G42.2).

Remedy

- Correct the program.

P153 Compensation interference

Details

An interference error has occurred while the tool radius compensation command (G41 or G42) or nose R compensation command (G41, G42 or G46) was being executed.

Remedy

- Correct the program.

P154 No spec: 3D compensation

Details

A three-dimensional compensation command was issued though it is out of specifications.

Remedy

- Check the specifications.

P155 Fixed cyc exec during compen

Details

A fixed cycle command has been issued in the radius compensation mode.

Remedy

- Issue a radius compensation cancel command (G40) to cancel the radius compensation mode that has been applied since the fixed cycle command was issued.

P156 R compen direction not defined

Details

A shift vector with undefined compensation direction was found at the start of G46 nose R compensation.

Remedy

- Change the vector to that which has the defined compensation direction.
- Change the tool to that which has a different tip point No.

P157 R compen direction changed

Details

During G46 nose R compensation, the compensation direction is reversed.

Remedy

- Change the G command to that which allows the reversed compensation direction (G00, G28, G30, G33, or G53).
- Change the tool to that which has a different tip point No.
- Enable "#8106 G46 NO REV-ERR".

P158 Illegal tip point

Details

An illegal tip point No. (other than 1 to 8) was found during G46 nose R compensation.

Remedy

- Correct the tip point No.

P159 C-CMP REMAINS

Details

One of the followings was commanded while the compensation has not been canceled (the compensation amount remained).

- (1) Automatic tool nose R compensation (G143)
- (2) Radius compensation (G145)
- (3) Plane selection (G17 to G19)
- (4) Skip (G31 or G31.1/G31.2/G31.3)
- (5) Fixed cycle for drilling (G81 to G89)
- (6) Compound type fixed cycle II (G74 to G76)

Remedy

- Cancel the compensation (with compensation amount "0") before commanding.
- Command the G00 move block before the block with a command among (1) to (6).

P160 G53 CMP. ERR

Details

- G53 was commanded during nose R compensation (by G41/G42/G46).
- G53 was commanded to the block where the nose R compensation mode is changed (with G40/G41/G42/G46).
- G53 was commanded while nose R compensation amount has not been cleared.

Remedy

- Correct the program.
- When issuing G53 after G40 command, move the compensation plane axis by G00/G01/G02/G03 command before issuing G53.

P161 No spec: 5ax tool R compensate**Details**

Tool radius compensation for 5-axis machining is not included in the specifications.

Remedy

- Check the specifications.

P162 Disable Cmd in 5ax tool R comp**Details**

A command (G or T command, etc) was issued during tool radius compensation for 5-axis machining, although it is disabled during the compensation.

Remedy

- Cancel the tool radius compensation for 5-axis machining.

P163 5 ax tool R comp is disable**Details**

Tool radius compensation for 5-axis machining was commanded in a mode where the command is disabled.

Remedy

- Cancel the mode that disables the command.

P170 No offset number**Details**

- No compensation No. (DOO, TOO or HOO) command was given when the radius compensation (G41, G42, G43 or G46) command was issued. Otherwise, the compensation No. is larger than the number of sets in the specifications.
- When setting the L system tool life management II, the tool group management program was executed with the tool life management disabled.

Remedy

- Add the compensation No. command to the compensation command block.
- Check the number of sets for the tool compensation Nos. and correct the compensation No. command to be within the number of sets.
- When setting the L system tool life management II ("#1096 T_Ltyp"="2"), enable the tool life management ("#1103 T_Life"="1") to execute a tool group management program.

P171 No spec:Comp input by prog G10**Details**

Compensation data input by program (G10) was commanded though it is out of specifications.

Remedy

- Check the specifications.

P172 G10 L number error**Details**

An address of G10 command is not correct.

Remedy

- Correct the address L No. of the G10 command.

P173 G10 P number error**Details**

The compensation No. at the G10 command is not within the permitted number of sets in the specifications.

Remedy

- Check the number of sets for the tool compensation Nos. and correct the address P designation to be within the number of sets.

P174 No spec:Comp input by prog G11

Details

Compensation data input by program cancel (G11) was commanded though there is no specification of compensation data input by program.

Remedy

- Check the specifications.

P177 Tool life count active

Details

Registration of tool life management data with G10 was attempted when the "usage data count valid" signal was ON.

Remedy

- The tool life management data cannot be registered during the usage data count. Turn the "usage data count valid" signal OFF.

P178 Tool life data entry over

Details

The number of registration groups, total number of registered tools or the number of registrations per group exceeded the range in the specifications.

Remedy

- Correct the number of registrations.

P179 Illegal group No.

Details

- A duplicate group No. was found at the registration of the tool life management data with G10.
- A group No. that was not registered was designated during the T****99 command.
- An M code command, which must be issued as a single command, coexists in the same block as that of another M code command.
- The M code commands set in the same group exist in the same block.

Remedy

- Register the tool life data once for one group: commanding with a duplicate group No. is not allowed.
- Correct to the group No.

P180 No spec: Drilling cycle

Details

A fixed cycle command (G72 - G89) was issued though it is out of specifications.

Remedy

- Check the specifications.
- Correct the program.

P181 No spindle command (Tap cycle)

Details

Spindle rotation speed (S) has not been commanded in synchronous tapping.

Remedy

- Command the spindle rotation speed (S) in synchronous tapping.
- When "#8125 Check Scode in G84" is set to "1", enter the S command in the same block where the synchronous tapping command is issued.

P182 Synchronous tap error

Details

- Connection to the main spindle unit was not established.
- The synchronous tapping was attempted with the spindle not serially connected under the multiple-spindle control I.

Remedy

- Check connection to the main spindle.
- Check that the main spindle encoder exists.
- Set 1 to the parameter #3024 (sout).

P183 No pitch/thread number**Details**

The pitch or number of threads has not been commanded in the tap cycle of a fixed cycle for drilling command.

Remedy

- Specify the pitch data and the number of threads by F or E command.

P184 Pitch/thread number error**Details**

- The pitch or the number of threads per inch is illegal in the tap cycle of the fixed cycle for drilling command.
- The pitch is too small for the spindle rotation speed.
- The thread number is too large for the spindle rotation speed.

Remedy

- Correct the pitch or the number of threads per inch.

P185 No spec: Sync tapping cycle**Details**

Synchronous tapping cycle (G84/G74) was commanded though it is out of specifications.

Remedy

- Check the specifications.

P186 Illegal S cmnd in synchro tap**Details**

S command was issued during synchronous tapping modal.

Remedy

- Cancel the synchronous tapping before issuing the S command.

P190 No spec: Turning cycle**Details**

A lathe cutting cycle command was issued though it is out of specifications.

Remedy

- Check the specification.
- Delete the lathe cutting cycle command.

P191 Taper length error**Details**

In the lathe cutting cycle, the specified length of taper section is illegal.

Remedy

- Set the smaller radius value than the axis travel amount in the lathe cycle command.

P192 Chamfering error**Details**

Chamfering in the thread cutting cycle is illegal.

Remedy

- Set a chamfering amount not exceeding the cycle.

P200 No spec: MRC cycle**Details**

The compound type fixed cycle for turning machining I (G70 to G73) was commanded though it is out of specifications.

Remedy

- Check the specifications.

P201 Program error (MRC)

Details

- The subprogram, called with a compound type fixed cycle for turning machining I command, has at least one of the following commands: reference position return command (G27, G28, G29, G30); thread cutting (G33, G34); fixed cycle skip-function (G31, G31.n).
- An arc command was found in the first movement block of the finished shape program in compound type fixed cycle for turning machining I.

Remedy

- Delete G27, G28, G29, G30, G31, G33, G34, and fixed cycle G codes from the subprogram called with the compound type fixed cycle for turning machining I commands (G70 to G73).
- Delete G02 and G03 from the first movement block of the finished shape program in compound type fixed cycle for turning machining I.

P202 Block over (MRC)

Details

The number of blocks in the shape program of the compound type fixed cycle for turning machining I is over 50 or 200 (the maximum number differs according to the model).

Remedy

- Set a 50/200 or less value for the number of blocks in the shape program called by the compound type fixed cycle for turning machining I commands (G70 to G73). (The maximum number differs according to the model).

P203 D cmd figure error (MRC)

Details

A proper shape will not be obtained by executing the shape program for the compound type fixed cycle for turning machining I (G70 to G73).

Remedy

- Correct the shape program for the compound type fixed cycle for turning machining I (G70 to G73).

P204 E cmd fixed cycle error

Details

A command value of the compound type fixed cycle for turning machining (G70 to G76) is illegal.

Remedy

- Correct the command value of the compound type fixed cycle for turning machining (G70 to G76).

P210 No spec: Pattern cycle

Details

A compound type fixed cycle for turning machining II (G74 to G76) command was commanded though it is out of specifications.

Remedy

- Check the specifications.

P220 No spec: Special fixed cycle

Details

There are no special fixed cycle specifications.

Remedy

- Check the specifications.

P221 No. of special fixed holes = 0

Details

"0" has been specified for the number of holes in special fixed cycle mode.

Remedy

- Correct the program.

P222 G36 angle error

Details

A G36 command specifies "0" for angle intervals.

Remedy

- Correct the program.

P223 G12/G13 radius error**Details**

The radius value specified with a G12 or G13 command is below the compensation amount.

Remedy

- Correct the program.

P224 No spec: Circular (G12/G13)**Details**

There are no circular cutting specifications.

Remedy

- Check the specifications.

P230 Subprogram nesting over**Details**

Over 8 times of subprogram calls have been done in succession from a subprogram.

- A M198 command was found in the program in the data server.
- The program in the IC card has been called more than once (the program in the IC card can be called only once during nested).

Remedy

- Correct the program so that the number of subprogram calls does not exceed 8 times.

P231 No sequence No.**Details**

The sequence No., commanded at the return from the subprogram or by GOTO in the subprogram call, was not set.

Remedy

- Specify the sequence Nos. in the call block of the subprogram.

P232 No program No.**Details**

- The machining program has not been found when the machining program is called.
- The file name of the program registered in IC card is not corresponding to O No.

Remedy

- Enter the machining program.
- Check the subprogram storage destination parameters.
- Ensure that the external device (including IC card) that contains the file is mounted.

P235 Program editing**Details**

Operation was attempted for the file under program editing.

Remedy

- Execute the program again after completion of program editing.

P240 No spec: Variable commands**Details**

A variable command (with #) was issued though it is out of specifications.

Remedy

- Check the specifications.

P241 No variable No.**Details**

The variable No. commanded is out of the range specified in the specifications.

Remedy

- Check the specifications.
- Correct the program variable No.

P242 = not defined at vrble set

Details

The "=" sign has not been commanded when a variable is defined.

Remedy

- Designate the "=" sign in the variable definition of the program.

P243 Can't use variables

Details

An invalid variable has been specified in the left or right side of an operation expression.

Remedy

- Correct the program.

P244 Invalid set date or time

Details

Date or time was set earlier than current date or time in the system variables (#3011, #3012) when the system lock was valid.

Remedy

- Date or time cannot be changed.
- Correct the program.

P250 No spec: Figure rotation

Details

Figure rotation (M98 I_J_P_H_L_) was commanded though it is out of specifications.

Remedy

- Check the specifications.

P251 Figure rotation overlapped

Details

Figure rotation command was issued during figure rotation.

Remedy

- Correct the program.

P252 Coord rotate in fig. rotation

Details

A coordinate rotation related command (G68, G69) was issued during figure rotation.

Remedy

- Correct the program.

P260 No spec: Coordinates rotation

Details

A coordinate rotation command was issued though it is out of specifications.

Remedy

- Check the specifications.

P261 G code illegal (Coord rot)

Details

Another G code or a T command has been issued in the block of coordinate rotation command.

Remedy

- Correct the program.

P262 Illegal modal (Coord rot)

Details

A coordinate rotation command has been issued during modal in which coordinate rotation is not allowed.

Remedy

- Correct the program.

P270 No spec: User macro

Details

A macro specification was commanded though it is out of specifications.

Remedy

- Check the specifications.

P271 No spec: Macro interrupt

Details

A macro interruption command has been issued though it is out of specifications.

Remedy

- Check the specifications.

P272 NC and macro texts in a block

Details

An executable statement and a macro statement exist together in the same block.

Remedy

- Place the executable statement and macro statement in separate blocks in the program.

P273 Macro call nesting over

Details

The number of macro call nests exceeded the limit imposed by the specifications.

Remedy

- Correct the program so that the macro calls do not exceed the limit imposed by the specifications.

P275 Macro argument over

Details

The number of argument sets in the macro call argument type II has exceeded the limit.

Remedy

- Correct the program.

P276 Illegal G67 command

Details

A G67 command was issued though it was not during the G66 command modal.

Remedy

- Correct the program.
- Issue G66 command before G67 command, which is a call cancel command.

P277 Macro alarm message

Details

An alarm command has been issued in #3000.

Remedy

- Refer to the operator messages on the diagnosis screen.
- Refer to the instruction manual issued by the machine tool builder.

P280 Brackets [] nesting over

Details

Over five times have the parentheses "[" or "]" been used in a single block.

Remedy

- Correct the program so that the number of "[" or "]" is five or less.

P281 Brackets [] not paired

Details

A single block does not have the same number of commanded parentheses "[" as that of "]".

Remedy

- Correct the program so that "[" and "]" parentheses are paired up properly.

P282 Calculation impossible

Details

The arithmetic formula is incorrect.

Remedy

- Correct the formula in the program.

P283 Divided by zero

Details

The denominator of the division is zero.

Remedy

- Correct the program so that the denominator for division in the formula is not zero.

P288 IF EXCESS

Details

Over ten times of IF statement nesting have been done.

Remedy

Correct the program so that the number of IF statement nesting does not exceed ten.

P289 IF-ENDIF MMC.

Details

An IF statement is not ended with ENDIF.
THEN/ELSE has been commanded while there is no IF command.

Remedy

- Correct the program so that IF statements are ended with ENDIFs.
- Put IF[condition] before THEN/ELSE command.

P290 IF sentence error

Details

There is an error in the "IF[<conditional>]GOTO(" statement.

Remedy

- Correct the program.

P291 WHILE sentence error

Details

There is an error in the "WHILE[<conditional>]DO(-END(" statement.

Remedy

- Correct the program.

P292 SETVN sentence error

Details

There is an error in the "SETVN(" statement when the variable name setting was made.

Remedy

- Correct the program.
- The number of characters in the variable name of the SETVN statement must be 7 or less.

P293 DO-END nesting over

Details

The number of DO-END nesting levels in the "WHILE[<conditional>]DO(-END(" statement has exceeded 27.

Remedy

- Correct the program so that the nesting levels of the DO-END statement does not exceed 27.

P294 DO and END not paired

Details

The DOs and ENDS are not paired off properly.

Remedy

- Correct the program so that the DOs and ENDS are paired off properly.

P295 WHILE/GOTO in tape

Details

There is a WHILE or GOTO statement on the tape during tape operation.

Remedy

- Apply memory mode operation instead of tape mode that does not allow the execution of the program with a WHILE or GOTO statement.

P296 No address (macro)

Details

A required address has not been specified in the user macro.

Remedy

- Correct the program.

P297 Address-A error

Details

The user macro does not use address A as a variable.

Remedy

- Correct the program.

P298 G200-G202 cmd in tape

Details

User macro G200, G201, or G202 was specified during tape or MDI mode.

Remedy

- Correct the program.

P300 Variable name illegal

Details

The variable names have not been commanded properly.

Remedy

- Correct the variable names in the program.

P301 Variable name duplicated

Details

A duplicate variable name was found.

Remedy

- Correct the program so that no duplicate name exists.

P310 Not use GMSTB macro code

Details

G, M, S, T, or B macro code was called during fixed cycle.

Remedy

- Correct the program.
- Correct the parameter settings.

P350 No spec: Scaling command

Details

The scaling command (G50, G51) was issued though it is out of specifications.

Remedy

- Check the specifications.

P360 No spec: Program mirror

Details

A mirror image (G50.1 or G51.1) command has been issued though the programmable mirror image specifications are not provided.

Remedy

- Check the specifications.

P370 No spec: Facing t-post MR

Details

The facing turret mirror image specifications are not provided.

Remedy

- Check the specifications.

P371 Facing t-post MR illegal

Details

- Mirror image for facing tool posts was commanded to an axis in external mirror image or parameter mirror image.
- The commanded mirror image for facing tool posts enables the mirror image for a rotary axis.

Remedy

- Correct the program.
- Correct the parameter settings.

P380 No spec: Corner R/C

Details

The corner R/C was issued though it is out of specifications.

Remedy

- Check the specifications.
- Delete the corner chamfering/corner rounding command in the program.

P381 No spec: Arc R/C

Details

Corner chamfering II or corner rounding II was commanded in the arc interpolation block though it is out of specifications.

Remedy

- Check the specifications.

P382 No corner movement

Details

The block next to corner chamfering/ corner rounding is not a travel command.

Remedy

- Replace the block succeeding the corner chamfering/ corner rounding command by G01 command.

P383 Corner movement short

Details

The travel distance in the corner chamfering/corner rounding command was shorter than the value in the corner chamfering/corner rounding command.

Remedy

- Set the smaller value for the corner chamfering/corner rounding than the travel distance.

P384 Corner next movement short

Details

The travel distance in the following block in the corner chamfering/corner rounding command was shorter than the value in the corner chamfering/corner rounding command.

Remedy

- Set the smaller value for the corner chamfering/corner rounding than the travel distance in the following block.

P385 Corner during G00/G33

Details

A block with corner chamfering/corner rounding was given during G00 or G33 modal.

Remedy

- Correct the program.

P390 No spec: Geometric**Details**

A geometric command was issued though it is out of specifications.

Remedy

- Check the specifications.

P391 No spec: Geometric arc**Details**

There are no geometric IB specifications.

Remedy

- Check the specifications.

P392 Angle < 1 degree (GEOMT)**Details**

The angular difference between the geometric line and line is 1° or less.

Remedy

- Correct the geometric angle.

P393 Inc value in 2nd block (GEOMT)**Details**

The second geometric block has a command with an incremental value.

Remedy

- Issue a command with an absolute value in the second geometric block.

P394 No linear move command (GEOMT)**Details**

The second geometric block contains no linear command.

Remedy

- Issue the G01 command.

P395 Illegal address (GEOMT)**Details**

The geometric format is invalid.

Remedy

- Correct the program.

P396 Plane selected in GEOMT ctrl**Details**

A plane switching command was issued during geometric command processing.

Remedy

- Complete the plane switching command before geometric command processing.

P397 Arc error (GEOMT)**Details**

In geometric IB, the circular arc end point does not contact or cross the next block start point.

Remedy

- Correct the geometric circular arc command and the preceding and following commands.

P398 No spec: Geometric1B**Details**

A geometric command was issued though the geometric IB specifications are not provided.

Remedy

- Check the specifications.

P411 Illegal modal G111

Details

- G111 was issued during milling mode.
- G111 was issued during nose R compensation mode.
- G111 was issued during constant surface speed.
- G111 was issued during mixed control (cross axis control).
- G111 was issued during fixed cycle.
- G111 was issued during polar coordinate interpolation.
- G111 was issued during cylindrical interpolation mode.

Remedy

- Before commanding G111, cancel the following commands.
- Milling mode
- Nose R compensation
- Constant surface speed
- Mixed control (cross axis control)
- Fixed cycle
- Polar coordinate interpolation
- Cylindrical interpolation

P412 No spec: Axis name switch

Details

Axis name switch (G111) was issued though it is out of specifications.

Remedy

- Check the specifications.

P420 No spec: Para input by program

Details

Parameter input by program (G10) was commanded though it is out of specifications.

Remedy

- Check the specifications.

P421 Parameter input error

Details

- The specified parameter No. or set data is illegal.
- An illegal G command address was input in parameter input mode.
- A parameter input command was issued during fixed cycle modal or nose R compensation.
- G10L70, G11 were not commanded in independent blocks.

Remedy

- Correct the program.

P430 R-pnt return incomplete

Details

- A command was issued to move an axis, which has not returned to the reference position, away from that reference position.
- A command was issued to an axis removal axis.

Remedy

- Execute reference position return manually.
- Disable the axis removal on the axis for which the command was issued.

P431 No spec: 2,3,4th R-point ret

Details

A command for second, third or fourth reference position return was issued though there are no such command specifications.

Remedy

- Check the specifications.

P432 No spec: Start position return

Details

Start position return (G29) was commanded though it is out of specifications.

Remedy

- Check the specifications.

P433 No spec: R-position check

Details

Reference position check (G27) was commanded though it is out of specifications.

Remedy

- Check the specifications.

P434 Compare error

Details

One of the axes did not return to the reference position when the reference position check command (G27) was executed.

Remedy

- Correct the program.

P435 G27 and M commands in a block

Details

An M command was issued simultaneously in the G27 command block.

Remedy

- Place the M code command, which cannot be issued in a G27 command block, in separate block from G27 command block.

P436 G29 and M commands in a block

Details

An M command was issued simultaneously in the G29 command block.

Remedy

- Place the M code command, which cannot be issued in a G29 command block, in separate block from G29 command block.

P438 G52 invalid during G54.1

Details

A local coordinate system command was issued during execution of the G54.1 command.

Remedy

- Correct the program.

P450 No spec: Chuck barrier

Details

The chuck barrier on command (G22) was specified although the chuck barrier is out of specifications.

Remedy

- Check the specifications.

P451 No spec: Stroke chk bef travel

Details

Stroke check before travel (G22/G23) was commanded though it is out of specifications.

Remedy

- Check the specifications.

P452 Limit before travel exists

Details

An illegal command, which places the axis travel start/end point in the prohibited area or moves the axis through the prohibited area, was detected when Stroke check before travel (G22) was commanded.

Remedy

- Correct the coordinate values of the axis address commanded in the program.

P460 Tape I/O error

Details

An error has occurred in the tape reader. Otherwise an error has occurred in the printer during macro printing.

Remedy

- Check the power and cable of the connected devices.
- Correct the I/O device parameters.

P461 File I/O error

Details

- A file of the machining program cannot be read.
- IC card has not been inserted.

Remedy

- In memory mode, the programs stored in memory may have been destroyed. Output all of the programs and tool data and then format the system.
- Ensure that the external device (including an IC card, etc) that contains the file is mounted.
- Correct the parameter settings for HD operation or IC card operation.

P462 Computer link commu error

Details

A communication error occurred during the BTR operation.

Remedy

- "L01 Computer link error" is displayed simultaneously. Take the remedy corresponding to the error No.

P480 No spec: Milling

Details

- Milling was commanded though it is out of specifications.
- Polar coordinate interpolation was commanded though it is out of specifications.

Remedy

- Check the specifications.

P481 Illegal G code (mill)

Details

- An illegal G code was used during the milling mode.
- An illegal G code was used during cylindrical interpolation or polar coordinate interpolation.
- The G07.1 command was issued during the tool radius compensation.

Remedy

- Correct the program.

P482 Illegal axis (mill)

Details

- A rotary axis was commanded during the milling mode.
- Milling was executed though an illegal value was set for the milling axis No.
- Cylindrical interpolation or polar coordinate interpolation was commanded during mirror image.
- Cylindrical interpolation or polar coordinate interpolation was commanded before the tool compensation was completed after the T command.
- G07.1 was commanded when cylindrical interpolation was not possible (there is no rotary axis, or external mirror image is ON).
- An axis other than a cylindrical coordinate system axis was commanded during cylindrical interpolation.

Remedy

- Correct the machining program, parameters and PLC interface signals.

P484 R-pnt ret incomplete (mill)**Details**

- Movement was commanded to an axis that had not completed reference position return during the milling mode.
- Movement was commanded to an axis that had not completed reference position return during cylindrical interpolation or polar coordinate interpolation.

Remedy

- Carry out manual reference position return.

P485 Illegal modal (mill)**Details**

- The milling mode was turned ON during nose R compensation or constant surface speed control.
- A T command was issued during the milling mode.
- The mode was switched from milling to cutting during tool compensation.
- Cylindrical interpolation or polar coordinate interpolation was commanded during the constant surface speed control mode (G96).
- The command unacceptable in the cylindrical interpolation was issued.
- A T command was issued during the cylindrical interpolation or polar coordinate interpolation mode.
- A movement command was issued when the plane was not selected just before or after the G07.1 command.
- A plane selection command was issued during the polar coordinate interpolation mode.
- Cylindrical interpolation or polar coordinate interpolation was commanded during tool radius compensation.
- The G16 plane in which the radius value of a cylinder is "0" was specified.
- A cylindrical interpolation or polar coordinate interpolation command was issued during coordinate rotation by program.

Remedy

- Correct the program.
- Issue G40 or G97 before issuing G12.1.
- Issue a T command before issuing G12.1.
- Issue G40 before issuing G13.1.
- Specify the radius value of a cylinder other than "0", or specify the X axis's current value other than "0" before issuing G12.1/G16.

P486 Milling error**Details**

- The milling command was issued during the mirror image (when parameter or external input is turned ON).
- Polar coordinate interpolation, cylindrical interpolation or milling interpolation was commanded during mirror image for facing tool posts.
- The start command of the cylindrical interpolation or polar coordinate interpolation was issued during the normal line control.

Remedy

- Correct the program.

P501 Cross (G110) impossible**Details**

Mixed control (cross axis control) command (G110) was issued in the following modes.

- During nose R compensation mode
- During pole coordinate interpolation mode
- During cylindrical interpolation mode
- During balance cut mode
- During fixed cycle machining mode
- During facing turret mirror image
- During constant surface speed control mode
- During hobbing mode
- During axis name switch

Remedy

- Correct the program.

P503 Illegal G110 axis

Details

- The commanded axis does not exist.
- The mixed control (cross axis control) (G110) was commanded to the axis for which the mixed control (cross axis control) is disabled.
- The number of axes included in the mixed control (cross axis control) (G110) command is exceeding the maximum number of axes per part system.

Remedy

- Correct the program.

P511 Synchronization M code error

Details

- Two or more synchronization M codes were commanded in the same block.
- The synchronization M code and "!" code were commanded in the same block.
- Synchronization with the M code was commanded in 3rd part system or more. (Synchronization with the M code is valid only in 1st part system or 2nd part system.)

Remedy

- Correct the program.

P520 Control axis superimposition/Designated axis illegal

Details

An axis which was impossible to superimpose was designated as a master axis or superimposing axis.

Remedy

Correct the program.

P521 Illegal synchronization axis

Details

The axis specified as a basic or synchronous axis of synchronization across part systems cannot be synchronized.

Remedy

- Correct the program.

P530 DEC. POINT ERR

Details

A decimal point was added to the address where the decimal point command is not allowed. ("#1274 ext10/bit0 (Type of address enabling/disabling decimal point command)")

Remedy

Do not add any decimal point to the addresses where the decimal point is not allowed.

P544 No spec: Wk instl err cmp

Details

The workpiece installation error compensation function is out of the specifications.

Remedy

- Check the specifications.

P545 Invlid cmd in wk instl err cmp

Details

During workpiece installation error compensation, a command impossible to issue (such as G command) was issued.

Remedy

- Check the program. If you wish to issue a command impossible to issue (such as G command) during workpiece installation error compensation, cancel workpiece installation error compensation once.

P546 Wk instl err cmp cmd invalid

Details

- Workpiece installation error compensation was commanded in a G modal in which commanding it is not allowed.
- An illegal G command was issued in the block that has a workpiece installation error compensation command.

Remedy

- Check the program. Also check the G modals which were issued at commanding the workpiece installation error compensation, and cancel illegal ones.
- Issue the G command in a separate block.

P547 Illegal wk instl err cmp cmd

Details

A command in which the rotary axis's travel distance exceeds 180 degrees was issued.

Remedy

- Divide the travel command so that the rotary axis's travel distance per block is less than 180 degrees.

P550 No spec: G06.2(NURBS)

Details

There is no NURBS interpolation option.

Remedy

- Check the specifications.

P551 G06.2 knot error

Details

The knot (k) command value is smaller than the value for the previous block.

Remedy

- Correct the program.
- Specify the knot by monotone increment.

P552 Start point of 1st G06.2 err

Details

The block end point immediately before the G06.2 command and the G06.2 first block command value do not match.

Remedy

- Match the G06.2 first block coordinate command value with the previous block end point.

P554 Invld manual interrupt in G6.2

Details

Manual interruption was executed in a block that applies the G06.2 mode.

Remedy

- Execute the manual interruption in the block that does not apply the G06.2 mode.

P555 Invalid restart during G06.2

Details

Restart was attempted from the block that applies G06.2 mode.

Remedy

- Restart from the block that does not apply the G06.2 mode.

P600 No spec: Auto TLM

Details

An automatic tool length measurement command (G37) was issued though it is out of specifications.

Remedy

- Check the specifications.

P601 No spec: Skip

Details

A skip command (G31) was issued though it is out of specifications.

Remedy

- Check the specifications.

P602 No spec: Multi skip

Details

A multiple skip command (G31.1, G31.2, G31.3 or G31 Pn) was issued though it is out of specifications.

Remedy

- Check the specifications.

P603 Skip speed 0

Details

The skip speed is "0".

Remedy

- Specify the skip speed.

P604 TLM illegal axis

Details

No axis was specified in the automatic tool length measurement block. Otherwise, two or more axes were specified.

Remedy

- Specify only one axis.

P605 T & TLM command in a block

Details

The T code is in the same block as the automatic tool length measurement block.

Remedy

- Specify the T code before the automatic tool length measurement block.

P606 T cmnd not found before TLM

Details

The T code was not yet specified in automatic tool length measurement.

Remedy

- Specify the T code before the automatic tool length measurement block.

P607 TLM illegal signal

Details

The measurement position arrival signal turned ON before the area specified by the D command or "#8006 ZONE d". Otherwise, the signal remained OFF to the end.

Remedy

- Correct the program.

P608 Skip during radius compen

Details

A skip command was issued during radius compensation processing.

Remedy

- Issue a radius compensation cancel (G40) command or remove the skip command.

P610 Illegal parameter**Details**

- The parameter setting is not correct.
- G114.1 was commanded while the spindle synchronization was selected with the PLC interface signal.
- G110 was commanded while the mixed control (cross axis control) was selected with the PLC interface signal.
- G125 was commanded while the control axis synchronization across part systems was selected with the PLC interface signal.
- G126 was commanded while the control axis superimposition was selected with the PLC interface signal.

Remedy

- Correct the settings of "#1514 expLinax (Exponential function interpolation linear axis)" and "#1515 expRotax (Exponential function interpolation rotary axis)".
- Correct the program.
- Correct the parameter settings.

P611 No spec: Exponential function**Details**

There is no specification for the exponential interpolation.

Remedy

- Check the specifications.

P612 Exponential function error**Details**

A travel command for exponential interpolation was issued during mirror image for facing tool posts.

Remedy

- Correct the program.

P700 Illegal command value**Details**

Spindle synchronization was commanded to a spindle that is not connected serially.

Remedy

- Correct the program.
- Correct the parameter settings.

P900 No spec: Normal line control**Details**

A normal line control command (G40.1, G41.1, or G42.1) was issued though it is out of specifications.

Remedy

- Check the specifications.

P901 Normal line control axis G92**Details**

A coordinate system preset command (G92) was issued to a normal line control axis during normal line control.

Remedy

- Correct the program.

P902 Normal line control axis error**Details**

- The normal line control axis was set to a linear axis.
- The normal line control axis was set to the linear type rotary axis II axis.
- The normal line control axis has not been set.
- The normal line control axis is the same as the plane selection axis.

Remedy

- Correct the normal line control axis setting.

P903 Plane chg in Normal line ctrl

Details

The plane selection command (G17, G18, or G19) was issued during normal line control.

Remedy

- Delete the plane selection command (G17, G18, or G19) from the program of the normal line control.

P920 No spec: 3D coord conv

Details

There is no specification for 3-dimensional coordinate conversion.

Remedy

- Check the specifications.

P921 Illegal G code at 3D coord

Details

The commanded G code cannot be performed during 3-dimensional coordinate conversion modal.

Remedy

- Refer to "MITSUBISHI CNC 700/70 Series Programming Manual (Machining Center System)" for usable G commands.
- When the parameter "#8158 Init const sur spd" is enabled, disable the parameter or issue the constant surface speed control cancel (G97) command.

P922 Illegal mode at 3D coord

Details

A 3-dimensional coordinate conversion command was issued during a modal for which 3-dimensional coordinate conversion cannot be performed.

Remedy

- Refer to "MITSUBISHI CNC 700/70 Series Programming Manual (Machining Center System)" for usable G commands.

P923 Illegal addr in 3D coord blk

Details

A G code and G68 was commanded in a block though the G code cannot be commanded with G68.

Remedy

- Refer to "MITSUBISHI CNC 700/70 Series Programming Manual (Machining Center System)" for usable G commands.

P930 No spec: Tool axis compen

Details

A tool length compensation along the tool axis command was issued though it is out of specifications.

Remedy

- Check the specifications.

P931 Executing tool axis compen

Details

There is a G code that cannot be commanded during tool length compensation along the tool axis.

Remedy

- Correct the program.

P932 Rot axis parameter error

Details

There is an illegal linear axis name or rotary axis name set in the rotary axis configuration parameters. There is an illegal setting in the parameter concerning the configuration of the inclined surface machining axis.

Remedy

- Set the correct value and turn the power ON again.

P940 No spec: Tool tip control

Details

There is no specification for tool tip center control.

Remedy

- Check the specifications.

P941 Invalid T tip control command

Details

A tool tip center control command was issued during a modal for which a tool tip center control command cannot be issued.

Remedy

- Correct the program.

P942 Invalid cmd during T tip ctrl

Details

A G code that cannot be commanded was issued during tool tip center control.

Remedy

- Correct the program.

P943 Tool posture command illegal

Details

In tool tip center control type 1, if the signs at the tool-side rotary axis or table base-side rotary axis start and finish points differ, a tool base-side rotary axis or table workpiece-side rotary axis rotation exists for the same block, and does not pass a singular point.

In tool tip center control type 2, the posture vector command is incorrect.

Remedy

- Correct the program.

P950 No spec: Tilt face machining

Details

Inclined surface machining option is not supported.

Remedy

- Check the specifications.

P951 Ill cmd in tilt face machining

Details

A forbidden command (G command, etc) was issued during inclined surface machining.

Remedy

- Check the program. If you want to execute a command (G command, etc) that is unavailable during inclined surface machining, cancel the inclined surface machining.

P952 Inclined face cut prohibited

Details

Inclined surface machining was commanded during the mode where the machining is unavailable. Inclined surface machining was commanded during interruption.

Remedy

- Check the program and see whether any unavailable mode is included during inclined surface machining command. If any, cancel that mode.

P953 Tool axis dir cntrl prohibited

Details

Tool axis direction control was commanded during the mode where the control is unavailable.

Remedy

- Check the program and see whether any unavailable mode is included during tool axis direction control. If any, cancel that mode.

P954 Inclined face command error

Details

The address to issue the inclined surface machining command is incorrect.

Remedy

- Check the program.

P955 Inclined face coord illegal

Details

Impossible to define an inclined surface with the values you specified.

Remedy

- Check the program.

P956 G68.2P10 surface not defined

Details

The coordinate system for the machining surface selected with G68.2P10 has not been defined.

Remedy

- Set the machining surface so that the coordinate system can be defined.

P957 Tool axis dir ctrl cmp amt 0

Details

When the tool axis direction control type 2 (G53.6) was commanded, a tool length compensation No. whose compensation amount is 0 was commanded.

Remedy

- Correct the program. Set the tool length compensation amount, or command a tool length compensation No. whose compensation amount is not 0.

P960 No spec: Direct command mode

Details

G05 P4 was commanded while direct command mode option is OFF.

Remedy

- Check the specifications.

P961 Invalid during dir cmnd mode

Details

- A G code other than G05 P0 was commanded in direct command mode.
- A sequence No. command, F code command, MSTB command or variable command was issued.
- A corner chamfering command or corner R command was issued.
- A travel command was issued to an axis that had not been command in the G05 P4 block.

Remedy

- Check the program.

P962 Dir cmnd mode cmnd invalid

Details

G05 P4 was commanded in a modal where direct command mode is not available.

Remedy

- Check the program.

P963 Illegal direct cmnd mode cmnd

Details

The commanded coordinate value was beyond the maximum travel distance in direct command mode.

Remedy

- Correct the coordinate value in direct command mode.

P990 PREPRO error**Details**

Combining commands that required pre-reading (nose R offset, corner chamfering/corner rounding, geometric I, geometric IB, and compound type fixed cycle for turning machining) resulted in eight or more pre-read blocks.

Remedy

- Delete some or all of the combinations of commands that require pre-reading.

Appendix 7

Operation Messages

The following messages display on each screen.

Appendix 7.1 Search-related Operation Messages

Message	Details
Searching	- The operation search is being executed.
Search completed	- The operation search was completed correctly.
Verifying	- The program is being verified.
Verifying stopped	- The program verification stopped.
Search error	<ul style="list-style-type: none"> - Could not find the designated ONB number. Review the ONB number or machining program settings. - The operation search could not be completed correctly. - When the parameter (#9005) of the tape mode port was set out of the range or when the port was not connected, an operation search of NC serial was performed. - The T code list search failed. Review the program name. - Could not find the machining program in HD or IC card. - Check the parameters for HD operation or IC card operation. - Tape search was executed during the HOST LINK communication.
Setting error	<ul style="list-style-type: none"> - The directory name exceeded the display range. A directory path for which the entire directory cannot be displayed cannot be designated in the directory name area. - The search is not possible because ONB number is not designated.
Restart search is completed	- The restart search was completed.
Executing restart search	- The restart search is being executed.
Execute operation search	<ul style="list-style-type: none"> - The program is not searched. Execute the operation search.
Can't cancel verify stop	- The compare stop cannot be canceled because the operation is not in a compare stop.
Executing top search	- The top search is being executed correctly.
Top search completed	- The top search was completed correctly.
Top search not completed	- The restart search (type 2) was executed without the top search.
Can't input data	- Data input was attempted during M, S, T, B history display.
Input some of ONB	- Awaiting ONB number input
Verifying stop posn already registered	- The verify stop position has already been registered.
No searched program	- The program has not been searched.
Program restarting	- The program is being restarted.
Program error	- The restart search was executed in the program with an error.
N/B block not found	- The restart search was executed, designating N or B No. not exist.
Restart search interrupted by reset	- Reset was executed during the restart search.
No. of repetitions exceeded	- The restart search was executed, designating the number of repetitions exceeding the number set in the program.
Program not found	- The restart search was executed, designating a program No. not exist.
List updating	- The file data in the list is being updated. Operation is invalid until the updating is completed.

Appendix 7.2 Graphic Display-related Operation Messages

Message	Details
Searching	- The check search is being executed.
Search error	- Could not find the designated ONB number. Review the ONB number or machining program settings. - The check search could not be completed correctly. - When the parameter (#9005) of the tape mode port was set out of the range or when the port was not connected, an operation search of NC serial was performed.
Executing automatic operation	- An attempt was made to perform operations such as parameter, tool compensation amount data and coordinate system offset settings during auto operation. (Input/output also possible during auto operation) - The machining program and MDI data that the operator is attempting to edit cannot be edited during auto operation. - It is not possible to be executed a check search or check start-up during auto operation. - An attempt was made to set the verify stop position during auto operation.
Setting error	- The directory name exceeded the display range. A directory path for which the entire directory cannot be displayed cannot be designated in the directory name area. - The check search is not possible because ONB number is not designated. - A non-existent axis name or setting that does not exist in the format was made when making the display mode settings. Set using an existing axis name. - Incorrect tool No. was specified at the execution of tool clear.
Execute operation search	- The program is not searched. Execute the operation search.
Checking	- The program check is being executed.
Check stopped	- The program check is being stopped.
Work form is illegal	- A workpiece is not drawn correctly because the two or more workpiece widths are set to "0".
Push [Check reset] menu	- An error occurred in the graphic check. Press the [Check reset] menu key to reset the error.
Executing trace	- The trace mode is valid.
Program check completed	- The trace in the program check completed with an M02/M30 code.
Reset complete	- The program check was reset.
Tool interfere with work	- The tool contacted the workpiece when performing rapid traverse (G0) movement with the interference check enabled.
Program checking	- The program check is being executed.
Executing reset operation	- The program check is being reset.
Executing trace(tip posn)	- The tip position trace mode is valid.
Executing BG simulation	- The back ground simulation is being executed.
Draw library inside error (n)	- Contact the service center.
Program check not possible	- Graphic check was attempted during the Computer link B operation.
Execute check search	- The program check is disabled. Execute the check search.
Solid check disabled (memory shortage)	- The 3D program check is disabled due to the memory shortage. Separate the programs and execute the check drawing again. Press the menu [Work init] once before performing the check drawing again.
Executing scale	Scale is being automatically adjusted.

Appendix 7.3 Variable (Common variables, local variables) - related Operation Messages

Message	Details
Erase? (Y/N)	- Message to confirm the line erase. [Y] or [INPUT]: Variables are deleted. [N]: Variables are not deleted.

Appendix 7.4 PLC Switch-related Operation Messages

Message	Details
Set up parameter ?(Y/N)	- Message to confirm the parameter setup. [Y] or [INPUT]:It will be possible to make settings. [N]:It will not be possible to make settings.

Appendix 7.5 Compensation-related (Tool compensation, coordinate system offset) Operation Messages

Message	Details
Erase? (Y/N)	- Message to confirm the erasing. [Y] or [INPUT]: Erase the data. [N]: Do not erase the data.
Clear all axes? (Y/N)	- Message to confirm the all axes clear. [Y] or [INPUT]: Clear the data for all axes. [N]: Do not clear the data.
Cannot return to origin	- Operations other than line paste, paste and data input cannot be undone. - It is the initial state. Cannot undo. - It cannot be undone if the previous setting is set in another part system. - The last operation was performed in other screen. Cannot undo the operation.
Clear all? (Y/N)	- Message to confirm the clearing the all data. [Y] or [INPUT]: Clear all data. [N]: Do not clear the data.
Input P number	- The coordinate system [Coord G54.1 P] menu was pressed. - The expansion workpiece coordinate system P No. was input.
Data clear complete	- Clearing of the collection data is complete.
Execute the collection data clear?	- Determines whether to clear the collection data. Press [Y] or [INPUT] to clear the data.

Appendix 7.6 Data Input/Output-related Operation Messages

Message	Details
Overwrite this file?(Y/N)	- Message to confirm the overwriting. [Y] or [INPUT]: Overwrite the file. [N]: Do not overwrite the file.
Over run error	- The buffer overran or overflowed.
Memory over	- The program cannot be written, because the memory capacity will be exceeded.
Edit lock B	- It is not possible to change machining program B (8000 to 8999: user standard subprogram) or machining program C (9000 to 9999: machine tool builder custom program) as edit lock B is enabled.
Edit lock C	- It is not possible to change machining program C (9000 to 9999: machine tool builder custom program) as edit lock C is enabled.
Can't make directory on this device	- Creation of a directory was attempted for a device that cannot have a directory.
Designated file does not exist	- The file specified in device A, and B does not exist. - The applicable file does not exist in the specified directory.
The file name is a directory	- A directory was designated for the file transfer. A directory cannot be transferred.
Change complete	- The data conversion completed correctly.
Changing	- The data is being converted.
Erase complete	- The file has been erased.
Erase ended. Some file not erased	- The file erasing completed, but there are some files that could not be erased.
Verify error	- An error occurred when performing a file verification.
Compare error. Compare next file?(Y/N)	- Message to confirm the comparison [Y] or [INPUT]: Compare the next file. [N]: Do not compare the next file.
Compare complete	- The data comparison completed.
Verifying	- The data is being compared.
The file already exists	- The input file name already exists. - The file name after renaming already exists.
Can't erase designated file	- Erasing was attempted of a file that cannot be erased.
Can't rename designated file	- An attempt was made to change the name of a file that cannot be renamed.
Can't condense designated file	- Condensing of a file that cannot be condensed was attempted.
Designated file is locked	- Changing was attempted of a locked file.
Can't open file for dev A	- Could not find the file for device A. Or, the file is in a state in which it cannot be accessed.
Can't open file for dev B	- Could not find the file for device B. Or, the file is in a state in which it cannot be accessed.
Can't read file for dev A	- Could not read in the file for device A. Recheck the connection status for device A or the input/output parameter setting.
Can't read file for dev B	- Could not read in the file for device B. Recheck the connection status for device B or the input/output parameter setting.

Message	Details
Can't close file for dev A	- Contact the service center
Can't close file for dev B	- Contact the service center.
Can't write file for dev A	- Could not write in the file for device B. Recheck the connection status for device A or the input/output parameter setting.
Can't write file for dev B	- Could not write in the file for device B. Recheck the connection status for device B or the input/output parameter setting.
Can't seek file for dev A	- Contact the service center.
Can't seek file for dev B	- Contact the service center.
File name not designated for dev A	- A file name was not designated for device A.
File name not designated for dev B	- A file name was not designated for device B.
Can't open directory for dev A	- Could not find a directory corresponding to device A.
Can't open directory for dev B	- Could not find a directory corresponding to device B.
Different devices designated in A and B	- The same device must be designated for devices A and B, but differing devices were designated.
Timeout error	- A timeout error occurred when communicating with the external device.
Checking	- Cannot be executed during a check
Dir create Complete	- Creation of the directory has been completed.
Can't make directory	- An error occurred while creating the directory.
Directory pass is illegal	- The designated directory path name is illegal. Input a correct directory path name.
Data protect	- Setting, erasing, parameter setting, etc., of the various data is prohibited, because the data protect key is validated.
Transfer complete	- The data transfer completed correctly.
Transferring	- The data is being transferred.
Parity H error	- A parity H error was detected.
Parity V error	- A parity V error was detected.
File entry over	- The No. of registration files designated in the specifications was exceeded, so the file could not be registered.
Program No. not found in the file	- There is no program number in the selected file.
Executing format	- The formatting is being executed.
Format complete	- The formatting completed.
Format error	- The formatting failed.
Framing error	- An error occurred between the NC and the external device.
Variable conversion error	- An error occurred during the M2 macro conversion, and the conversion failed.

Message	Details
Merge complete	- The data merge completed.
Merge execution	- The data merge is being executed.
Memory alloc error	- Securing of the communication data range failed.
Rename complete	- The rename has been completed.
OK? (Y/N)	- Message to confirm the operation. [Y] or [INPUT]: Execute the operation [N]: Cancel the operation.
I/O not ready	- An error occurred between the NC and the external device.
I/O parameter error	- The external device settings and input/output parameters do not match.
I/O port busy	- Input/output was not possible as the I/O port is busy.
FD write protect	- The FD is write-protected. Release the write protection.
PLC running	- An attempt was made to input a user PLC during PLC RUN. - Stop the PLC on the maintenance screen.
FD not ready	- An attempt was made to perform an FD operation search with no FD. - An attempt was made to display the FD list with no FD.
MemoryCard not ready	- An attempt was made to perform operations with no memory card.
DS not ready	- An attempt was made to perform operations with no data server.
USB memory not ready	- Operation was attempted when an USB memory is not inserted.
Can't write in READ-ONLY file	- Contact the service center.
Condense complete	- Condensing has been completed.
A directory does not exist	- The specified directory does not exist.
Setting complete normally	- Decryption code setting file of the system lock was set normally.
Guidance data loading	This will display only when the guidance data is loading from a memory card. It will display when a memory card for guidance is inserted after the NC has started and reading will take a few seconds to complete. (E70 only)
No guidance data in MemoryCard	Guidance data from memory card could not be read. Insert memory card with guidance data before displaying guidance. (E70 only)

Appendix 7.7 Parameter-related Operation Messages

Message	Details
Designate copy end posn	- The copy start position was specified using the cursor. Continue and specify the copy end position using the cursor.
Copy start posn and end posn reversed	- When the copy range was designated, a position before the start position was designated as the end position.
Columns of copy start and end different	- A different column (axis or part system) was specified for the copy start/end position at the screen with the arrangement configuration for each axis and part system.
Copy range is inadequate	- The rename has been completed.
Setting error	- The port is already being used. - The parameter HOST LINK was turned ON during the Anshin-net communication.
Setting error : column n	- The nth column setting data is inappropriate when multiple axes were set at the same time (/ division). (Settings have been made up to the (n-1)th column.)
Password is illegal	- The password designated for displaying the MachineParameter screen is illegal.
Input the password	- The menu key for first displaying the Machine Parameter screen was pressed after the power was turned ON.
Paste error	- An attempt was made to paste in a different parameter from the copy parameter.
Paste? (Y/N)	- Message to confirm the operation when pasting. [Y] or [INPUT]: Paste the data at the current cursor position. [N]: Do not paste the data.
Data protect	- Setting, erasing, parameter settings, etc., of the various data is prohibit, because the data protect key is validated.
Executing automatic operation	- An attempt was made to make parameter settings during auto operation.
Can't select	- The password designated for displaying the machine parameters has not been input. - Display of the machine parameters was attempted on the [Param No.] menu, but the password has not been input. Press the [Machine param] menu, and input the password for displaying the machine parameters.
No odd number for R register start No.	- An odd number cannot be used for R register start No. Use an even number.

Appendix 7.8 Measurement-related Operation Messages

Message	Details
TLM switch OFF	- Measurement, retrieving of the skip position, writing the coordinates data etc. was attempted when the TLM switch was OFF.
Can't take-in skip posn	- Could not retrieve the skip position. Check the following: < When measuring the workpiece > 1. Is the name of the axis to be measured designated in the basic axis(I, J, K)? 2. Is the axis that executed the axis movement a measurement axis? < When measuring the rotation > 1. Is the name of the axis to be measured designated in the coordinate rotation plane (horizontal axis, vertical axis)? 2. Is the axis that executed the axis movement a measurement axis?
Can't write coordinates data	- Could not obtain the measured axis No. - The measured angle was illegal. - Could not write into the coordinate system offset. Measure again. - The work coordinate offset data was attempted to set when the measurement counter does not have the necessary values. - The work coordinate offset date was attempted to set in the slave axis.
Sensor take in not possible	- Could not retrieve the position measured with the touch sensor. Measure again.
Can't measure	- Measurement failed.
Sensor signal was illegally turned on	- The sensor signal was already ON when the tool measurement mode (TLM) signal was validated. - The sensor signal turned ON when there was no axis movement after the tool measurement mode (TLM) signal was validated. - The sensor signal turned ON at a position within 100 μ m from the final entry start position. - Move the axis in a safe direction after turning the sensor signal OFF or turning the tool measurement mode signal OFF.
Can't write compensation data	- The cursor position and the cell for writing the compensation amount (length dimension, radius dimension) do not match. Match the cursor position with the cell for writing the compensation amount.
Offset No. not found	- During manual tool length measurement, the sensor was turned ON designating tool compensation No. not exist. - During manual tool length measurement, the measurement method was switched to manual tool length measurement 2 designating tool compensation No. not exist. - Correctly set the R register of compensation No.
TLM axis is illegal	- During 2 or more axes movement, the tool length measurement was executed by turning the sensor ON. Keep the tool away from the sensor and execute the measurement by one axis.
TLM axis not returned to ref. position	- The tool length measurement was executed by tuning the sensor ON for the axis in which dog-type reference point return has not been executed. Carry out reference point return for the measurement axis.
Can't write rotation parameter	- The measured result cannot be set in the process parameter.

Message	Details
Can't calculate center & angle for rot	<ul style="list-style-type: none"> - Three points necessary for calculation are not retrieved. - Center shift amount or sensor radius was failed to retrieve. - Calculation of the center and the angle was failed.
Input 0 to coord center & angle for rot	<ul style="list-style-type: none"> - The center and the angle are not "0". Set "0" in the parameter "#8623 Coord rot centr (H)", "#8624 Coord rot centr (V)" and "#8627 Coord rot angle".
Can't calculate	<ul style="list-style-type: none"> - Hole center cannot be determined.
Meas axis not returned to ref. position	<ul style="list-style-type: none"> - The workpiece measurement was executed when dog-type reference point return has not been executed. Carry out reference point return for the measurement axis.

Appendix 7.9 Tool (Tool registration, tool life) -related Operation Messages

Message	Details
Designated group already exists	<ul style="list-style-type: none"> - An already existing group No. was designated when changing the group No. (Tool life screen (grp)) - An already existing group No. was designated when newly creating the group. (Tool life screen (grp list)) Designate a group No. that does not already exist.
Designated group does not exist	- Erasing was attempted on the Tool life screen (grp list) of a group that does not exist.
Can't register group	- The group registration process on the Tool life screen (grp list) failed.
Can't delete group	- The group deletion process on the Tool life screen (grp list) failed.
Erase? (Y/N)	<ul style="list-style-type: none"> - Message to confirm the erasing. [Y] or [INPUT]: Erase the data [N]: Do not erase the data.
Delete all groups? (Y/N)	<ul style="list-style-type: none"> - Message to confirm the erasing of all groups. [Y] or [INPUT]: Erase all groups [N]: Do not erase all groups.
Can't delete all groups	- All groups' deletion cannot be executed because data protection key (KEY 1) is validated or automatic operation mode is validated, etc. during all groups' deletion. All groups' deletion cannot be executed because nothing has been registered to group, also.
Pot number not exist	<ul style="list-style-type: none"> - The set pot number does not exist. Check the pot number.
Create new file? (Y/N)	<ul style="list-style-type: none"> - Message to confirm the operation when newly creating data, files, etc. [Y] or [INPUT]: Newly create. [N]: Cancel the operation.
Input the tool number	- Waiting tool number input.
Clear not possible	- The clear range is incorrect.
Spindle/standby tool display not possible	- The spindle standby cannot be displayed due to the user PLC setting. Contact the machine tool builder.
Format tool life data? (Y/N)	- Determines whether to format the tool life management data. When [Y] is input, the formatting is executed.
Tool life format complete	- The tool life management data formatting completed.
Exists in spindle/standby. Set? (Y/N)	- An attempt was made to set the same No. as the tool No. for spindle/standby.
Exists in magazine 1. Set? (Y/N)	- An attempt was made to set the same No. as the tool No. that has been registered to the valid magazine.
Exists in magazine 2. Set? (Y/N)	- An attempt was made to set the same No. as the tool No. that has been registered to the valid magazine.
Exists in magazine 3. Set? (Y/N)	- An attempt was made to set the same No. as the tool No. that has been registered to the valid magazine.
Exists in magazine 4. Set? (Y/N)	- An attempt was made to set the same No. as the tool No. that has been registered to the valid magazine.
Exists in magazine 5. Set? (Y/N)	- An attempt was made to set the same No. as the tool No. that has been registered to the valid magazine.

Appendix 7.10 Editing-related Operation Messages

Message	Details
Buffer correct not possible	- Buffer correction cannot be performed for this program. - Buffer correction was attempted during the BTR operation.
Can't write into file	- Could not write the data to the memory with the buffer correction. Contact the service center.
Overwrite this file?(Y/N)	- Message to confirm when registering MDI [Y] or [INPUT]: Overwrite the file. [N]: Do not overwrite the file.
Memory over	- The program cannot be written, because the memory capacity will be exceeded.
Designated character string not found	- Could not find the search results and character string in the program.
Save current file?(Y/N)	- Message to confirm the saving. [Y] : Save the changes to the current file. [N] : Do not save the changes to the current file.
A file does not exist	- An attempt was made to select and edit a non-existent file.
Executing	- Following menu's process is executing now: "Line paste", "Line clear", "Undo", "String search", "String replace", "Miss warning", or "Next miss".
Designated file does not exist	- An attempt was made to select and erase a non-existent file.
Erase complete	- The data erasing completed.
Can't erase designated file	- The selected file cannot currently be erased.
Designated file does not exist	- A file that does not exist was designated when file editing.
Designated file already exists	- When creating a new file, a file name was designated that already exists.
Replace? (Y/N)	- Message to confirm the character string replacement. [Y] or [INPUT]: Replace the character string. [N]: Do not replace the character string.
File access error	- Contact the Service Center.
File open error	- The designated file is already open.
Editing	- A program is being edited on the screen. Save the program to write it into the memory.
Program entry over	- The program could not be registered in the memory when attempted, because the No. of registrations designated in the specifications would be exceeded.
Block char nos over	- The character number limitation in one block was exceeded.
Paste error	- Pasting was attempted within the copy range of the same file.
Copy range is inadequate	- The copy range designation is inadequate. Check whether the designated range exists. - The range was designated exceeding 100 lines during mass editing.
Area designation is inadequate	- The area designation is inadequate. Check whether the designated area exists.
Designated line is out of program range	- Designation was attempted of a line No. larger than the No. of lines in the entire program.

Message	Details
MDI no setting	- Editing of the MDI was started, but the MDI setting was incomplete.
Abs/Inc mode is illegal	- During playback editing: G90 was set when control parameter "Playback G90" was OFF. G91 was set when control parameter "Playback G90" was ON.
MDI search complete	- The MDI search completed.
Can't search in MDI mode	- The restart search was attempted during MDI mode. - Execute the restart search after switching other than MDI mode.
MDI Set ended	- MDI setting was completed.
MDI Setting error	- MDI setting cannot be executed.
MDI search error	- Could not execute the MDI search.
MDI entry complete	- MDI entry has been completed.
Can't edit except in MDI mode	- "#1144 mdlkof" (MDI setting lock) is "0" and therefore it is not possible to edit the MDI program in a mode other than MDI mode.
Input miss was detected	- An input miss was detected.
Input miss was not detected	- A search was performed for an input miss, however, none was found.
Can't edit a file except in NC memory	- Editing cannot be performed at the edit window for programs other than those in the NC memory.
Save it	- The cursor was tried to move beyond the editable range during mass-editing. Save, then operate again.
Save not possible	- A special file (history file etc.) that cannot be saved was edited and an attempt was made to save it. Perform an operation to quit editing. - Failed saving due to file size over, etc. during mass-editing. - Setting of "#1166 fixpro" was illegal. Use the settings for a regular program. - MDI cannot be entered due to MDI editing mode. Press INPUT key and finish editing.
Save left side file? (Y/N)	- Message to confirm whether saving the left side file of the multi-program display type [Y]: Save the change [N]: Do not save the change
Save right side file? (Y/N)	- Message to confirm whether saving the right side file of the multi-program display type [Y]: Save the change [N]: Do not save the change
Can't edit because of size over	- The program cannot be written, because the memory capacity will be exceeded. - If the memory capacity of the transfer designation device is exceeded during the automatic backup, increase the available memory of the device.
Can't edit the searched file	- The serial file cannot be edited.
DS not ready	- Operation was attempted when a DS was not inserted. - Creating or opening a program was attempted when a DS was not inserted.
FD not ready	- The FD operation search was attempted when an FD was not inserted. - The FD list display was attempted when an FD was not inserted. - Creating or opening a program was attempted when an FD was not inserted.

Message	Details
MemoryCard not ready	- Operation was attempted when a memory card was not inserted.
USB memory not ready	- Operation was attempted when an USB memory is not inserted.
This cannot be specified	- Invalid special characters (/E, etc.) were set.
Loading	- Loading file.
Saving	- Saving file.
Can't execute playback edit	- The playback editing cannot be executed because the right side area is mass-editing mode. - Playback editing was attempted while program file to be edited is not designated. Display a program file in the right side area.
Program display lock C	- The program display or search cannot be executed. Review the parameter "#1121 pglk_c" (program display lock).
Line feed code error: Close file	Attempt was made to display a part mixed with EOB for "CR,LF" and EOB for "LF" during high-capacity editing.
Read-only file - Can't edit	- The target program cannot be edited in this screen because it is being edited in the custom screen.
Read-only as the file is being edited	- The target program is opened as read-only because it is being edited in the custom screen.
Can't write into being edited file	The target program cannot be overwritten-transferred, merged, or entered MDI because it is being edited in the custom screen.

Appendix 7.11 Diagnosis-related Operation Messages

Message	Details
Erase? (Y/N)	- Message to confirm alarm history clear operation [Y] or [INPUT]: Erase the data [N]: Do not erase the data.
Can't write data	- The data cannot be written.
Device is illegal	- The designated device is inadequate.
Modal output not possible	- The modal output process failed.
Modal clear not possible	- The modal cancel process failed.
Continue display not possible	- Continuous display is not possible because data is not set at the cursor position.
One-shot output not possible	- The one-shot output process failed.
Setting data not found	- The data has not been set.
Select a menu	- A device No. was set without selecting a menu operation. Press any operation menu and input the device No. with a menu highlighted.

Appendix 7.12 Maintenance-related Operation Messages

Message	Details
Password is illegal	- The input password is incorrect.
Input password	- The [Password] menu key was pressed, and the password input mode was entered. Input a password.
Now making back-up	- Currently backing up system data and the user PLC program to a specified device.
Performing Backup	- The SRAM data is being backed up on the HD.
Backup complete	- Backup of the SRAM data on the HD has been completed. - Back up of system data and user PLC program to a specified device has been completed.
Backup error	- An error occurred while backing up the SRAM data on the HD.
Select directory to backup	- Select area by moving cursor, using ↑ and ↓ keys. Press the "INPUT" key to confirm.
Select directory to restore	- Select file by moving cursor, using ↑ and ↓ keys. Press the "INPUT" key to confirm.
Executing format	- The formatting is being executed correctly.
Format complete	- The formatting completed correctly.
Format error	- The NC memory formatting failed. Contact the nearest service center.
Quit HMI?(Y/N)	- Message to confirm the HMI quitting [Y] or [INPUT]: Quit the HMI. [N]: Do not quit the HMI.
Format NC memory?(Y/N)	- Message to confirm the NC memory formatting [Y] or [INPUT]: Start formatting the NC memory. [N]: Do not format the NC memory.
Execute SRAM backup?(Y/N)	- Message to confirm the SRAM back up [Y] or [INPUT]: The SRAM data is backed up to the HD. [N]: The SRAM data is not backed up to the HD.
PLC running. Does it stop?(Y/N)	- Message to confirm the PLC STOP [Y] or [INPUT]: Backup the SRAM data on the HD. [N]: Do not backup the SRAM data on the HD.
Restoring	- The system data and user PLC program are now being restored to the NC from a specified device.
Restore complete	- Restoration of system data and user PLC program to the NC from a specified device has been completed.
Auto adjust error	- The H/W status cannot be read properly, and therefore it is not possible to perform auto adjustments. Check the remote I/O unit. Perform manual adjustments. - The unit is defective. Replace the unit.
Change Ope. test mode	- Operation of the Operation test screen was attempted when the operation adjustment mode was not selected.
Test mode sig valid signal is now OFF	- The operation adjustment mode cannot be selected because the operation adjustment mode valid signal (R9998/bit0) is 0.

Message	Details
Auto adjust complete	- Analog output adjustment completed normally.
Auto adjust execution	- Performing analog output adjustment normally.
Execute? (Y/N)	- Message to confirm the operation [Y] or [INPUT]: The currently selected operation is performed. [N]: The currently selected operation is not performed.
Unit not equipped	- The machine is not equipped with an analog output unit.
A serial number is inaccurate	- The system data to be restored and the serial number in the NC do not match, and therefore it is not possible to restore. - Check to ensure that the serial number in the NC has been set and that the system data to be restored matches.
Operating aux axis	- It is not possible to set parameter and input/output data during auxiliary axis operation. - It is not possible to change the display axis during auxiliary axis operation.
Delete the allocation? (Y/N)	Message to confirm deletion of the parameter allocation. The allocation will be deleted by choosing [Y].
SRAM release assignment error	The memory allocation for the SRAM open function is not executed correctly. Review the allocation in the SRAM open parameter screen and reformat it.
Is it OK to delete the group? (Y/N)	Message to confirm deletion of the group of the line where a cursor is placed. Parameters in the group will be deleted by choosing [Y].

Appendix 7.13 Data Sampling-related Operation Messages

Message	Details
Executing sampling	- The waveform data is being sampled.
Input the axis name	- This appears when the data type is selected in the Ch1 or Ch2 data setting area. Input the name of the axis to be sampled.
Input axis name/signal No./bit	- This appears when the data type is selected in the Ch1 or Ch2 data setting area. Set the sampling conditions common for Ch1 and Ch2.
Input device name/device No.	- Input device name/device No.
Input file/sub-ID/item/data	- This appears when an NC file is selected in the Ch1 or Ch2 data setting area.
Change the area	- Change the area.
Sampling conditions are illegal	- The data cannot be sampled as the setting conditions are illegal. Review the data, vertical scale, sampling rate and horizontal scale on the Condition setting screen.
Can't start sampling	- "#1224 aux08/bit0" is "0" and sampling start-up cannot be performed.
The collection invalid	- The parameters are set to prevent data being collected. Check the parameters.
The collection begin?	- Determines whether to start data collection. Press [Y] or [INPUT] to start data collection.
The collection stop?	- Determines whether to stop data collection. Press [Y] or [INPUT] to stop data collection.
The collection is being executed	- An attempt was made to start data collection while data collection was being performed.
The collection is stopping	- An attempt was made to stop data collection while data collection was stopped.
The collection invalid	- The data collection is set invalid in the parameter. Check the parameter.
Scroll execution	- The waveform display is being scrolled.
Refresh execution	- The waveform is being refreshed.

Appendix 7.14 Absolute Position Detection-related Operation Messages

Message	Details
Setting absolute position set	- Setting from the screen was attempted of absolute position detection data when the "Absolute Position Set" was not ON. Press the menu key [Absolute Position Set] to turn it ON.
Not the abs position detection system	- An absolute position detection system has not been selected for the currently selected axis. The machine parameter (Axis specification parameter "#2049 type") must be set.
Axis name inappropriate	- The set axis name is inappropriate. Check the axis name.
Not passed on grid	- The absolute position basic point was set without passing the grid after the power ON in the dogless-type absolute position detection. Return one grid back and repeat the procedure.
Can't start	- Settings of "#0 absolute posn set", "#2 Z-point" and "#2055 pushf" are not adequate. - "AbsEncoder: Serial data error" alarm (Z71 0005) has occurred. Check the parameter and the alarm.
Illegal direction	- JOG starting direction is illegal in the machine end stopper method of the dogless-type absolute position detection.

Appendix 7.15 System Setup-related Operation Messages

Message	Details
Initial parameter creating	- The initial parameter is being created.
Initial parameter transferring	- The initial parameter is being transferred.
Spindle initial parameter transferring	- The spindle initial parameter is being transferred.
Can't write data	- The data cannot be written. - Setting of the initial parameter failed. - Contact the service center.
Param set ended. Format NC memory? (Y/N)	- After completing the parameter setting, it determines whether executing the file format or not. Enter [Y] or [INPUT] to execute the file format.
Write sample ladder? (Y/N)	- It determines whether executing writing the sample PLC program or not. Enter [Y] or [INPUT] to start writing the sample PLC program.
Sample ladder not found	- The file to set the sample PLC program is lost. Contact the service center.

Appendix 7.16 Automatic Backup-related Operation Messages

Message	Details
Auto backup disabled (Device illegal)	- Set a correct value in the device No. of the automatic backup device.
Auto backup disabled (No DS)	- When turning ON the power next time, insert DS.
Auto backup disabled (No memory card)	- When turning ON the power next time, insert the memory card.
Auto backup disabled (No USB memory)	- When turning ON the power next time, insert the USB memory.
Auto backup proceeding	- Wait for the automatic backup to complete.
Auto backup completed	- The automatic back up is completed.
Memory over	- The memory capacity of the transfer designation device was exceeded during the automatic backup. Increase the available memory of the transfer designation device.
File access error	- A file access error occurred during the automatic backup. Contact the service center.
Can't make directory	- The storage destination directory of the automatic backup data described in the custom definition file does not exist. Create the directory of the storage destination.
Write protect	- The memory card is write-protected. Release the write protection.

Appendix 7.17 Alarm History-related Operation Messages

Message	Details
The collection begin? (Y/N)	- Determines whether to start alarm history. Press [Y] or [INPUT] to start alarm history.
The collection stop? (Y/N)	- Determines whether to stop alarm history. Press [Y] or [INPUT] to stop alarm history.
The collection is being executed	- An attempt was made to start alarm history while alarm history was being performed.
The collection is stopping	- An attempt was made to stop alarm history while alarm history was being stopped.
Execute the collection data clear?(Y/N)	- Determines whether to clear alarm history. Press [Y] or [INPUT] to clear alarm history.
Data clear complete	- The alarm history cleared was completed.
The collection begin	- The alarm history was started.
The collection stop	- The alarm history was stopped.

Appendix 7.18 DeviceNet-related Operation Messages

Message	Description
Cannot connect to external PLC link	The external PLC link screen cannot be displayed because the Q series extension base is not connected.
This unit cannot set parameter	Parameters cannot be set because the selected slot's unit type is other than DeviceNet.
Saving to F-ROM	Indicates that saving to DeviceNet unit's Flash ROM is in progress by the saving to the Flash ROM operation.
Saving to F-ROM complete	Indicates that saving to DeviceNet unit's Flash ROM by the saving to Flash ROM operation is completed.
Parameter error	An error occurred as a result of parameter check when saving the parameters to the Flash ROM by the saving to Flash ROM operation. Refer to the error code on "ErrInfo(Master)" or "ErrInfo(Slave)", and correct the parameters. After correcting them, execute the Saving to Flash-ROM operation again.
Execute saving to F-ROM ?(Y/N)	After changing the setting data, this message is displayed if trying to change to the screen other than DeviceNet parameter screen without saving to the Flash ROM. [Y] or [INPUT]: Execute the saving operation [N]: Saving operation will not be executed
Clearing F-ROM	Indicates that the clearing the Flash ROM operation by the clearing Flash ROM operation is in progress.
F-ROM clear complete	Indicates that the Flash ROM clearing by the Flash ROM clear operation is completed.
F-ROM clear error	An error occurred while clearing the DeviceNet unit's Flash ROM by the Flash ROM clear operation. Execute the Flash ROM clear operation again. If this message persists, it might be due to a breakdown of the DeviceNet unit. Replace the unit.
Executing auto configuration	Indicates that the auto configuration by the auto configuration execution operation is in progress.
Auto configuration complete	Indicates that the auto configuration by the auto configuration execution operation is completed.
Auto configuration error	Auto configuration operation is not properly completed although the auto configuration start up operation is executed. (Time-out occurred.) Start up the auto configuration again after confirming the devices are connected properly.
Update complete	Indicates that the update for display is completed after reading the parameters from the buffer memory again.
Designated node number not found	Designated node number is not in the parameter as a result of search.
Saving to F-ROM error	An error occurred while saving to the Device Net unit's Flash ROM by the Saving to the Flash ROM operation is in progress. Execute the saving to Flash ROM operation again. If this message persists, it might be due to a breakdown of the DeviceNet unit. Replace the unit.

Appendix 7.19 Other Operation Messages

Message	Details
Executing automatic operation	- Cannot be performed during automatic operation. Perform the operation again after automatic operation has been completed.
Setting error	- The setting data is inadequate. (Alphabetic characters were set where only numeric characters can be set, etc.) - The data has not been set. - There is no specification.
Data range error	- The input data exceeded the range. Set the value again within the range.
Data protect	- Setting, erasing, parameter setting, etc., of the various data is prohibited, because the data protect key is validated. Reconsider the data protect key setting.
Write protect	- Attempted to create a new program file in the write-protected device - Opened the program file of the write-protected device - Attempted to save the program file of the write-protected device - Attempted to correct the buffer for the write-protected file. - Attempted to edit or correct the buffer for the read-only program file.
Edit lock B	- It is not possible to change machining program B (8000 to 8999: user standard subprogram) or machining program C (9000 to 9999: machine tool builder custom program) as edit lock B is enabled.
Edit lock C	- It is not possible to change machining program C (9000 to 9999: machine tool builder custom program) as edit lock C is enabled.
Origin set not possible	- The operation is in a state in which origin set is not possible. Check the parameter "#1123 origin (Origin set prohibited)" setting. - Check that the axis has stopped. - Check that idling (post-reset status) is currently being performed.
Can't command manual value	- The manual numerical value protect is valid and therefore it is not possible to perform a manual numerical value command.
Getting T code list	- T code list is being retrieved.
T code list complete	- Retrieving T code list is completed.
Load meter display not possible	- The load meter cannot be displayed. Contact the machine tool builder.
Pallet running	- Each setting was executed during pallet running.
APC executing	- Each setting was executed during automatic pallet changer executing.

Appendix 8

User Parameters

The parameters with "(PR)" requires the CNC to be turned OFF after the settings. Turn the power OFF and ON to enable the parameter settings.

(Note) This parameter description is common for M700V/M70V/E70 Series.

It is written on the assumption that all option functions are added.

Confirm with the specifications issued by the machine tool builder before starting use.

【#1025】 I_plane Initial plane selection

Select the plane to be selected when the power is turned ON or reset.

- 1: X-Y plane (G17 command state)
- 2: Z-X plane (G18 command state)
- 3: Y-Z plane (G19 command state)

【#1026】 base_I Base axis I

Set the names of the basic axes that compose the plane.

Set the axis name set in "#1013 axname".

If all three items ("base_I", "base_J" and "base_K") do not need to be set, such as for 2-axis specifications, input "0", and the parameter will be blank.

Normally, when X, Y and Z are specified respectively for base_I, _J, _K, the following relation will be established:

- G17: X-Y
- G18: Z-X
- G19: Y-Z

Specify the desired axis name to set an axis address other than above.

---Setting range---

Axis names such as X, Y or Z

【#1027】 base_J Base axis J

Set the names of the basic axes that compose the plane.

Set the axis name set in "#1013 axname".

If all three items ("base_I", "base_J" and "base_K") do not need to be set, such as for 2-axis specifications, input "0", and the parameter will be blank.

Normally, when X, Y and Z are specified respectively for base_I, _J, _K, the following relation will be established:

- G17: X-Y
- G18: Z-X
- G19: Y-Z

Specify the desired axis name to set an axis address other than above.

---Setting range---

Axis names such as X, Y or Z

【#1028】 base_K Base axis K

Set the names of the basic axes that compose the plane.

Set the axis name set in "#1013 axname".

If all three items ("base_I", "base_J" and "base_K") do not need to be set, such as for 2-axis specifications, input "0", and the parameter will be blank.

Normally, when X, Y and Z are specified respectively for base_I, _J, _K, the following relation will be established:

- G17: X-Y
- G18: Z-X
- G19: Y-Z

Specify the desired axis name to set an axis address other than above.

---Setting range---

Axis names such as X, Y or Z

【#1029】 aux_I Flat axis I

Set the axis name when there is an axis parallel to "#1026 base_I".

---Setting range---

Axis names such as X, Y or Z

【#1030】 aux_J Flat axis J

Set the axis name when there is an axis parallel to "#1027 base_J".

---Setting range---

Axis names such as X, Y or Z

【#1031】 aux_K Flat axis K

Set the axis name when there is an axis parallel to "#1028 base_K".

---Setting range---

Axis names such as X, Y or Z

【#1037(PR)】 cmdtyp Command type

Set the G code list and compensation type for programs.

- | | |
|--------------------------|---|
| 1 : List1(for M) | Type I (one compensation amount for one compensation No.) |
| 2 : List1(for M) | Type II (shape and wear compensation amounts for one comp. No.) |
| 3 : List2(for L) | Type III (shape and wear compensation amounts for one comp. No.) |
| 4 : List3(for L) | Ditto |
| 5 : List4(for special L) | Ditto |
| 6 : List5(for special L) | Ditto |
| 7 : List6(for special L) | Ditto |
| 8 : List7(for special L) | Ditto |
| 9 : List8(for M) | M2 form at type Type I
(one compensation amount for one compensation No.) |
| 10 : List8(for M) | M2 form at type Type II
(shape and wear compensation amounts for one compensation No.) |

There are some items in the specifications that can be used or cannot be used according to the value set in this parameter.

The file structure may also change depending on the compensation data type.

(Note) When this parameter is changed, the file system will be changed after the power is turned ON.

So always execute format.

The new format will be enabled after turning the power ON again.

Setting order

(1) cmdtyp changeover -> (2) Turn power ON again -> (3) Format -> (4) Turn power ON again

【#1041(PR)】 I_inch Initial state (inch)

Select the unit system for the program travel amount when the power is turned ON or reset and for position display.

- 0: Metric system
- 1: Inch system

(Note) The units of the following data are converted by "#1041 I_inch".

- Command unit at power ON and reset (Inch/metric command mode)

But under the following conditions, the unit will follow G20/G21 command modal even at reset.

When reset modal is retained ("#1151 rstint"="0")

When G code group 06 reset modal is retained ("#1210 RstGmd/bit5" ON)

- Unit system for position display (counter, user parameter, tool, work offset)

- User parameter I/O unit

- Parameter unit of user parameters concerning length and speed

- Arc error parameter (#1084 RadErr)

【#1063】 mandog Manual dog-type

Select the manual reference position return method for the second return (after the coordinate system is established) and later.

The initial reference position return after the power ON is performed with dog-type return, and the coordinate system will be established.

(This setting is not required when the absolute position detection is used.)

- 0: High speed return
- 1: Dog-type

【#1074】 I_Sync Initial synchronous feed

Select the feedrate mode at turning ON the power or reset.
 0: Asynchronous feed (feed per minute)
 1: Synchronous feed (feed per revolution)

【#1075】 I_G00 Initial G00

Select the linear command mode at turning ON the power or reset.
 0: Linear interpolation (G01 command state)
 1: Positioning (G00 command state)

【#1076】 AbsInc ABS/INC address (for L system only)

Select the command method for the absolute and incremental commands.
 0: Use G command for the absolute and incremental commands.
 1: Use axis name for the absolute and incremental commands.
 (The axis name in "#1013 axname" will be the absolute command, "#1014 incax" will be the incremental command.)

When "1" is selected, using two axis names, one each for the absolute and incremental commands, allows to issue the absolute and incremental commands appropriately to an axis.

【#1078】 Decpt2 Decimal point type 2

Select the increment of position commands that do not have a decimal point.
 0: Minimum input command unit (follows "#1015 cunit")
 1: 1mm (or 1inch) unit (For the dwell time, 1s unit is used.)

【#1080】 Dril_Z Specify boring axis (for M system only)

Select a fixed cycle hole drilling axis.
 0: Use an axis vertical to the selected plane as hole drilling axis.
 1: Use the Z axis as the hole drilling axis regardless of the selected plane.

【#1084】 RadErr Arc error

Set the tolerable error range when the end point deviates from the center coordinate in the circular command.

---Setting range---
 0 to 1.000 (mm)

【#1085】 G00Drn G00 dry run

Select whether to apply dry run (feed at manual setting speed instead of command feedrate) to the G00 command.
 0: Not apply to G00. (move at rapid traverse rate)
 1: Apply to G00. (move at manual setting speed)

【#1086】 G0Intp G00 non-interpolation

Select the G00 travel path type.
 0: Move linearly toward the end point. (interpolation type)
 1: Move to the end point of each axis at the rapid traverse feedrate for each axis. (non-interpolation)

(Note) If this parameter is set to "1", neither of the following functions will be available: rapid traverse constant inclination acceleration/deceleration and rapid traverse constant inclination multi-step acceleration/deceleration.

【#1091】 Mpoint Ignore middle point

Select how to handle the middle point during G28 and G30 reference position return.
 0: Pass the middle point designated in the program and move to the reference position.
 1: Ignore the middle point designated in the program and move straight to the reference position.

【#1103】 T_Life Validate life management

Select whether to use the tool life management.
 0: Not use
 1: Use

【#1104】 T_Com2 Tool command method 2

Select how to handle the tool command in the program when "#1103 T_Life" is set to "1".
 0: Handle the command as group No.
 1: Handle the command as tool No.

(Note) In the case of the tool life management III, the program tool command will be handled as the tool No. regardless of the setting.

【#1105】 T_Sel2 Tool selection method 2

Select the tool selection method when "#1103 T_Life" is set to "1".
 0: Select in order of registered No. from the tools used in the same group.
 1: Select the tool with the longest remaining life from the tools used or unused in the same group.

【#1106】 Tcount Life management (for L system only)

Select the input method when address N is omitted in inputting the data (G10 L3 command) for tool life management function II.
 0: Time specified input
 1: Number of times specified input

【#1126】 PB_G90 Playback G90

Select the method to command the playback travel amount in the playback editing.
 0: Incremental value
 1: Absolute value

【#1128】 RstVCI Clear variables by resetting

Select how to handle the common variables when resetting.
 0: Common variables won't change after resetting.
 1: The following common variables will be cleared by resetting:
 #100 to #149 when 100 sets of variables are provided.
 #100 to #199 when 200 sets or more of variables are provided.

【#1129】 PwrVCI Clear variables by power-ON

Select how to handle the common variables when the power is turned ON.
 0: The common variables are in the same state as before turning the power OFF.
 1: The following common variables will be cleared when the power is turned ON:
 #100 to #149 when 100 sets of variables are provided.
 #100 to #199 when 200 sets or more of variables are provided.

【#1148】 I_G611 Initial high precision

Set the high accuracy control mode for the modal state when the power is turned ON.
 0: G64 (cutting mode) at power ON
 1: G61.1 (high-accuracy control mode) at power ON
 (Note) When the option of high-accuracy control in 2 part systems is enabled, it will be enabled in both systems.

【#1149】 cireft Arc deceleration speed change

Select whether to decelerate at the arc entrance or exit.
 0: Not decelerate
 1: Decelerate

【#1171】 taprov Tap return override

Set the tap return override value for the synchronous tapping.
 When "0" is set, it will be regarded as 100%.

---Setting range---
 0 to 100 (%)

【#1185】 spd_F1 F1 digit feedrate F1

Set the feedrate for the F command in the F 1-digit command ("#1079 F1digit" is set to "1").
Feedrate when F1 is issued (mm/min)
When "#1246 set08/bit6" is set to "1" and F 1-digit feed is commanded, the feedrate can be increased/decreased by operating the manual handle.

---Setting range---
0 to 1000000 (mm/min)

【#1186】 spd_F2 F1 digit feedrate F2

Set the feedrate for the F command in the F 1-digit command ("#1079 F1digit" is set to "1").
Feedrate when F2 is issued (mm/min)
When "#1246 set08/bit6" is set to "1" and F 1-digit feed is commanded, the feedrate can be increased/decreased by operating the manual handle.

---Setting range---
0 to 1000000 (mm/min)

【#1187】 spd_F3 F1 digit feedrate F3

Set the feedrate for the F command in the F 1-digit command ("#1079 F1digit" is set to "1").
Feedrate when F3 is issued (mm/min)
When "#1246 set08/bit6" is set to "1" and F 1-digit feed is commanded, the feedrate can be increased/decreased by operating the manual handle.

---Setting range---
0 to 1000000 (mm/min)

【#1188】 spd_F4 F1 digit feedrate F4

Set the feedrate for the F command in the F 1-digit command ("#1079 F1digit" is set to "1").
Feedrate when F4 is issued (mm/min)
When "#1246 set08/bit6" is set to "1" and F 1-digit feed is commanded, the feedrate can be increased/decreased by operating the manual handle.

---Setting range---
0 to 1000000 (mm/min)

【#1189】 spd_F5 F1 digit feedrate F5

Set the feedrate for the F command in the F 1-digit command ("#1079 F1digit" is set to "1").
Feedrate when F5 is issued (mm/min)
When "#1246 set08/bit6" is set to "1" and F 1-digit feed is commanded, the feedrate can be increased/decreased by operating the manual handle.

---Setting range---
0 to 1000000 (mm/min)

【#1205】 G0bdcc Acceleration and deceleration before G0 interpolation

- 0: Post-interpolation acceleration/deceleration is applied to G00.
- 1: Pre-interpolation acceleration/deceleration is applied to G00 even in the high accuracy control mode.
- 2: Rapid traverse constant inclination multi-step acceleration/deceleration is enabled.

(Note) Set "0" for the 2nd part system and the following.
When the option of high-accuracy control option in 2 part systems is enabled, "1" can be set for the 2nd part system.

【#1206】 G1bF Maximum speed

Set a cutting feedrate when applying pre-interpolation acceleration/deceleration.
When high-accuracy control time constant expansion is valid, set the maximum of cutting feed clamp speed of each axis.

---Setting range---
1 to 999999 (mm/min)

【#1207】 G1btL Time constant

Set a cutting feed time constant when applying pre-interpolation acceleration/deceleration. When set to "0", the time constant will be clamped at 1ms.

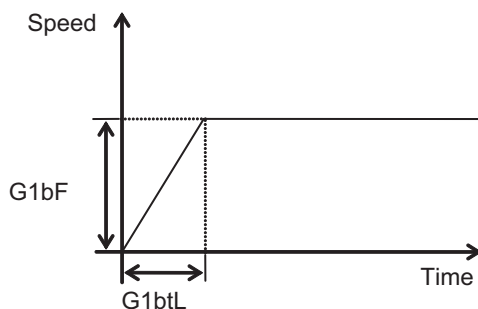
**---Setting range---**

Without high-accuracy control time constant expansion: 0 to 5000 (ms)
With high-accuracy control time constant expansion: 0 to 30000 (ms)

Cutting feed Acc Cutting feed acceleration

Displays cutting feed acceleration.

【#1209】 cirdcc Arc deceleration speed

Set the deceleration speed at the arc entrance or exit.

---Setting range---

1 to 999999 (mm/min)

【#1302】 AutoRP Automatic return by program restart

Select the method to move to the restart position when restarting the program.

0: Move the system manually to the restart position and then restart the program.

1: The system automatically moves to the restart position at the first activation after the program restarts.

【#1506】 F1_FM Upper limit of F1-digit feedrate

Set the maximum value up to which the F 1-digit feedrate can be changed.

---Setting range---

0 to 1000000 (mm/min)

【#1507】 F1_K F 1-digit feedrate change constant

Set the constant that determines the speed change rate per manual handle graduation in F 1-digit feedrate change mode.

---Setting range---

0 to 32767

【#1568】 SfiltG1 G01 soft acceleration/deceleration filter

Set the filter time constant for smoothly changing the acceleration rate for the cutting feed acceleration/deceleration in pre-interpolation acceleration/deceleration.

---Setting range---

0 to 200 (ms)

Notch frequency Hz

Displays the notch frequency(Hz) for the S-pattern filter set in "#1568 SfiltG1 (G01 soft acceleration/deceleration filter)"

【#1569】 SfiltG0 G00 soft acceleration/deceleration filter

Set the filter time constant for smoothly changing the acceleration rate for the rapid traverse acceleration/deceleration in pre-interpolation acceleration/deceleration.

---Setting range---
0 to 200 (ms)

【#1570】 Sfilt2 Soft acceleration/deceleration filter 2

Set the filter time constant for smoothly changing the acceleration rate in pre-interpolation acceleration/deceleration.
This will be disabled when "0" or "1" is set.

---Setting range---
0 to 26 (ms)

Notch frequency Hz

Displays the notch frequency(Hz) for the S-pattern filter set in "#1570 Sfilt2 (Soft acceleration/deceleration filter 2)".

【#1571】 SSSdis SSS control adjustment coefficient fixed value selection

Fix the shape recognition range for SSS control.

【#1926(PR)】 Global IP address IP address

Set the main CPU's IP address.
Set the NC IP address seen from an external source.

【#1927(PR)】 Global Subnet mask Subnet mask

Set the subnet mask for the IP address.

【#1928(PR)】 Global Gateway Gateway

Set the IP address for the gateway.

【#1934(PR)】 Local IP address

Set the HMI side CPU's IP address.
(Note) This parameter is valid only for M700/M700VW Series.

【#1935(PR)】 Local Subnet mask

Set the HMI side CPU's subnet mask.
(Note) This parameter is valid only for M700/M700VW Series.

【#2001】 rapid Rapid traverse rate

Set the rapid traverse feedrate for each axis.
(Note) The maximum value to be set depends on the machine specifications.

---Setting range---
1 to 1000000 (mm/min)

【#2002】 clamp Cutting feedrate for clamp function

Set the maximum cutting feedrate for each axis.
Even if the feedrate in G01 exceeds this value, the clamp will be applied at this feedrate.

---Setting range---
1 to 1000000 (mm/min)

【#2010】 fwd_g Feed forward gain

Set a feed forward gain for pre-interpolation acceleration/deceleration.
The larger the set value, the smaller the theoretical control error will be. However, if a machine vibration occurs, set the smaller value.

---Setting range---
0 to 200 (%)

【#2068】 G0fwdg G00 feed forward gain

Set a feed forward gain for G00 pre-interpolation acceleration/deceleration.
The larger the setting value, the shorter the positioning time during in-position checking.
If a machine vibration occurs, set the smaller value.

---Setting range---
0 to 200 (%)

【#2096】 crncsp Minimum corner deceleration speed

Set the minimum clamp speed for corner deceleration in the high-accuracy control mode. Normally set "0".

(Note) This parameter is invalid during SSS control.

---Setting range---
0 to 1000000 (mm/min)

【#2109】 Rapid (H-precision) Rapid traverse rate for high-accuracy control mode

Set the rapid traverse rate for each axis in the high-accuracy control mode. "#2001 rapid" will be used when "0" is set.

---Setting range---
0 to 1000000 (mm/min)

【#2110】 Clamp (H-precision) Cutting feed clamp speed for high-accuracy control mode

Set the cutting feed maximum speed for each axis in the high-accuracy control mode. "#2002 clamp" will be used when "0" is set.

---Setting range---
0 to 1000000 (mm/min)

【#7914】 ROT_PREFILT Rotary axis prefilter time constant

Set the time constant for rotary axis prefilter.
Setting this parameter can smoothen the tool angle change (rotary axis' motion) under tool center point control.
When set to "0", "Rotary axis prefiltering" will be disabled.

---Setting range---
0 to 200 (ms)

【#8001】 WRK COUNT M

Set the M code for counting the number of the workpiece repeated machining.
The number of the M-codes set by this parameter is counted.
The No. will not be counted when set to "0".

---Setting range---
0 to 999

【#8002】 WRK COUNT

Set the initial value of the number of workpiece machining. The number of current workpiece machining is displayed.

---Setting range---
0 to 999999

【#8003】 WRK COUNT LIMIT

Set the maximum number of workpiece machining.
A signal will be output to PLC when the number of machining times is counted to this limit.

---Setting range---
0 to 999999

【#8004】 SPEED

Set the feedrate during automatic tool length measurement.

---Setting range---
1 to 1000000 (mm/min)

【#8005】 ZONE r

Set the distance between the measurement point and deceleration start point.

---Setting range---
0 to 99999.999 (mm)

【#8006】 ZONE d

Set the tolerable range of the measurement point.
An alarm will occur when the sensor signal turns ON before the range, set by this parameter, has not been reached from the measurement point, or when the signal does not turn ON after the range is passed.

---Setting range---
0 to 99999.999 (mm)

【#8007】 OVERRIDE

Set the override value for automatic corner override.

---Setting range---
0 to 100 (%)

【#8008】 MAX ANGLE

Set the maximum corner opening angle where deceleration should start automatically.
When the angle is larger than this value, deceleration will not start.

---Setting range---
0 to 180 (°)

【#8009】 DSC. ZONE

Set the position where deceleration starts at the corner.
Designate at which length point before the corner deceleration should start.

---Setting range---
0 to 99999.999 (mm)

【#8010】 ABS. MAX. (for L system only)

Set the maximum value when inputting the tool wear compensation amount.
A value exceeding this setting value cannot be set.
Absolute value of the input value is set.
(If a negative value is input, it is treated and set as a positive value.)
If "0" is input, this parameter will be disabled.

---Setting range---
0 to 999.999 (mm)
(Input setting increment applies)

【#8011】 INC. MAX. (for L system only)

Set the maximum value for when inputting the tool wear compensation amount in the incremental mode.

A value exceeding this setting value cannot be set.

Absolute value of the input value is set.

(If a negative value is input, it is treated and set as a positive value.)

If "0" is input, this parameter will be disabled.

---Setting range---

0 to 999.999 (mm)

(Input setting increment applies)

【#8012】 G73 n

Set the return amount for G73 (step cycle).

Set the return amount for MITSUBISHI CNC special format G83.1.

---Setting range---

0 to 99999.999 (mm)

【#8013】 G83 n

Set the return amount for G83 (deep hole drilling cycle).

---Setting range---

0 to 99999.999 (mm)

【#8014】 CDZ-VALE (for L system only)

Set the screw cut up amount for G76 and G78 (thread cutting cycle).

---Setting range---

0 to 127 (0.1 lead)

【#8015】 CDZ-ANGLE (for L system only)

Set the screw cut up angle for G76 and G78 (thread cutting cycle).

---Setting range---

0 to 89 (°)

【#8016】 G71 MINIMUM (for L system only)

Set the minimum value of the last cutting amount by the rough cutting cycle (G71, G72).

The cutting amount of the last cutting will be the remainder. When the remainder is smaller than this parameter setting, the last cycle will not be executed.

---Setting range---

0 to 999.999 (mm)

【#8017】 G71 DELTA-D (for L system only)

Set the change amount of the rough cutting cycle.

The rough cutting cycle (G71, G72) cutting amount repeats $d + \Delta d$, d , $d - \Delta d$ using the value (d) commanded with D as a reference. Set the change amount Δd .

---Setting range---

0 to 999.999 (mm)

【#8018】 G84/G74 n

Set the retract amount m in a G84/G74/G88 pecking tapping cycle.

(Note) In the case of a normal tapping cycle, set to "0".

【#8019】 R COMP

Set a compensation coefficient for reducing a control error in the reduction of a corner roundness and arc radius.

The larger the set value is, the smaller the theoretical error will be. However, since the speed at the corner goes down, the cycle time will be extended.

Coefficient = 100 - set value

(Note) This function will be enabled when "#8021 COMP_CHANGE" is set to "0".

---Setting range---

0 to 99 (%)

Theoretical radius decrease error amount

Displays the theoretical radius decrease error amount, ΔR (mm), from the automatic calculation by NC.

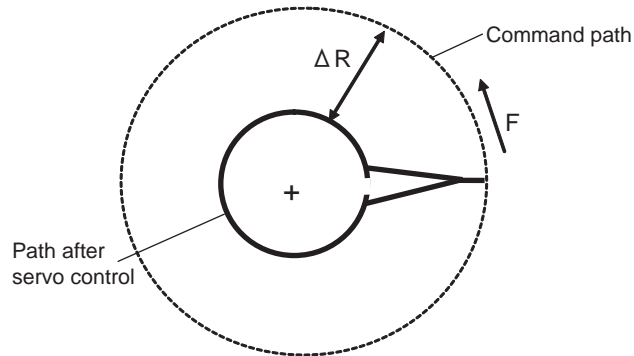

Theoretical radius decrease amount in arc

R5mm arc deceleration speed

Displays a deceleration speed(mm/min) along an arc of 5(mm) radius.

R1mm arc deceleration speed

Displays a deceleration speed(mm/min) along an arc of 1(mm) radius.

【#8020】 DCC ANGLE

Set the minimum value of an angle (external angle) that should be assumed to be a corner. When an inter-block angle (external angle) in high-accuracy mode is larger than the set value, it will be determined as a corner and the speed will go down to sharpen the edge.

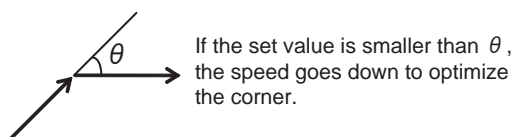

(Note) If "0" is set, it will be handled as "5" degrees.

---Setting range---

0 to 89 (°)

0: 5 degree (Equals to setting "5")

Theoretical corner dull amount

Displays the corner dull amount Δc (mm) in respect to the corner's angle (external angle) θ (°).

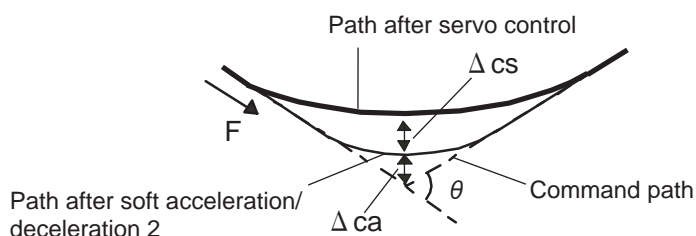

Theoretical roundness amount at corner

ca(mm): Error (Δ) caused by the soft acceleration/deceleration 2

cs(mm): Error (Δ) caused by the servo system

Corner deceleration speed

Display corner deceleration speed c (mm/min) for the corner of the angle (external angle) with θ (°).

Theoretical dull amount at 90 degree

Display corner dull amount when the angle is 90 degree.

Corner deceleration speed at 90 degree

Display corner deceleration speed when the angle is 90 degree.

【#8021】 COMP_CHANGE

Select whether to share or separate the compensation coefficient at the corner/curve during the high-accuracy control mode.

0: Share ("#8019 R COMP" is applied.)

1: Separate

- Corner : #8022 CORNER COMP

- Curve : #8023 CURVE COMP

(Note) Set "1" when using SSS control.

【#8022】 CORNER COMP

Set the compensation coefficient to further reduce or increase the roundness at the corner during the high-accuracy control mode.

Coefficient = 100 - setting value

(Note) This is valid when "#8021 COMP CHANGE" is set to "1".

Reference to "#8020 Corner decreasing speed" for theoretical corner roundness amount, corner decreasing speed, theoretical 90 degree dull amount, 90 degree corner decreasing speed.

---Setting range---

-1000 to 99 (%)

【#8023】 CURVE COMP

Set the compensation coefficient to further reduce or increase the radius reduction amount at the curve (arc, involute, spline) during the high-accuracy control mode.

Coefficient = 100 - setting value

(Note) This is valid when "#8021 COMP CHANGE" is set to "1".

For theoretical radius reduction error amount, R5mm arc deceleration speed and R1mm arc deceleration speed, refer to "#8019 R COMP".

---Setting range---

-1000 to 99 (%)

【#8025】 SPLINE ON (for M system only)

Select whether to enable the spline function.

0: Disable

1: Enable

Spline interpolation is valid during G61.2 modal, regardless of this setting.

【#8026】 CANCEL ANG. (for M system only)

Set the angle where the spline interpolation is temporarily canceled.

When the angle made by blocks exceeds this parameter setting value, spline interpolation will be canceled temporarily. In consideration of the pick feed, set a value a little smaller than the pick feed angle.

---Setting range---

0 to 180 (°)

0: 180 (°)

【#8027】 Toler-1 (for M system only)

Set the maximum chord error (tolerance) in a block that includes an inflection point. Set the tolerance applicable when the applicable block is developed to fine segments by CAM. (normally about 10 μ m)

When "0.000" is set, the applicable block will be linear.

---Setting range---

0.000 to 100.000 (mm)

【#8028】 Toler-2 (for M system only)

Set the maximum chord error (tolerance) in a block that includes no inflection point. Set the tolerance applicable when the applicable block is developed to fine segments by CAM. (normally about 10 μ m)

When "0.000" is set, the applicable block will be linear.

---Setting range---

0.000 to 100.000 (mm)

【#8029】 FairingL (for M system only)

Set the length of the block subject to fairing.

(Enabled when "#8033 Fairing ON" is set to "1".)

---Setting range---

0 to 100.000 (mm)

【#8030】 MINUTE LENG (for M system only)

Set the fine-segment length where the spline interpolation is temporarily canceled.

When the length of one block exceeds this parameter setting value, spline interpolation is canceled temporarily and linear interpolation is performed. Set a value a little smaller than one block length of the program.

If "-1" is set, spline interpolation will be performed regardless of block length.

---Setting range---

-1 to 127 (mm)

0: 1 (mm)

【#8033】 Fairing ON (for M system only)

Select whether to use the fairing function.

0: Not use

1: Use

Fairing function is enabled during G61.2 modal, regardless of this setting.

【#8034】 AccClamp ON (for M system only)

Select the method for clamping the cutting speed.

0: Clamp with parameter "#2002 clamp" or the corner deceleration function.

1: Clamp the cutting speed with acceleration judgment.

(Enabled when "#8033 Fairing ON" is set to "1".)

【#8036】 CordecJudge (for M system only)

Select the condition to decide a corner.

0: A corner is decided from the angle of the neighboring block.

1: A corner is decided from the angle of the neighboring block, excluding minute blocks.

(Enabled when "#8033 Fairing ON" is set to "1".)

【#8037】 CorJudgeL (for M system only)

Set the length of the block to be excluded when deciding a corner.

(Enabled when "#8036 CordecJudge" is set to "1".)

---Setting range---

0 to 99999.999 (mm)

【#8041】 C-rot.R

Set the length from the center of the normal line control axis to the tool tip. This is used to calculate the turning speed at the block joint.

This is enabled during the normal line control type II.

---Setting range---

0.000 to 99999.999 (mm)

【#8042】 C-ins.R

Set the radius of the arc to be automatically inserted into the corner during normal line control.

This is enabled during the normal line control type I.

---Setting range---

0.000 to 99999.999 (mm)

【#8043】 Tool HDL FD OFS

Set the length from the tool holder to the tool tip.

---Setting range---

0.000 to 99999.999 (mm)

【#8044】 UNIT*10

Set the command increment scale.

The scale will be "1" when "0" is set.

---Setting range---

0 to 10000 (fold)

0: One fold

【#8051】 G71 THICK

Set the amount of cut-in by the rough cutting cycle (G71, G72)

---Setting range---

0 to 99999.999 (mm)

【#8052】 G71 PULL UP

Set the amount of pull-up when returning to the cutting start point for the rough cutting cycle (G71, G72).

---Setting range---

0 to 99999.999 (mm)

【#8053】 G73 U

Set the X-axis cutting margin of the forming rough cutting cycle (G73).

---Setting range---

-99999.999 to 99999.999 (mm)

【#8054】 G73 W

Set the Z-axis cutting margin of the forming rough cutting cycle (G73).

---Setting range---

-99999.999 to 99999.999 (mm)

【#8055】 G73 R

Set how many times cutting will be performed in the forming rough cutting cycle (G73).

---Setting range---

0 to 99999 (times)

【#8056】 G74 RETRACT

Set the amount of retract (amount of cut-up) of the cutting-off cycle (G74, G75).

---Setting range---

0 to 999.999 (mm)

【#8057】 G76 LAST-D

Set the amount of final cut-in by the compound type thread cutting (G76).

---Setting range---

0 to 999.999 (mm)

【#8058】 G76 TIMES

Set how many times the amount of final cut-in cycle (G76 finish margin) will be divided in the compound type thread cutting (G76).

---Setting range---

0 to 99 (times)

【#8059】 G76 ANGLE

Set the angle (thread angle) of the tool nose in the compound type thread cutting (G76).

---Setting range---

0 to 99 (°)

【#8060】 G71 ERR

Set the tolerable error range to avoid a program error (a shape change at pocket machining) against minute inversion when the finished shape's Z axis (or X axis at G72 command) does not move monotonously.

---Setting range---

0.000 to 0.010 (mm)

【#8071】 3-D CMP (for M system only)

Set the value of the denominator constants for 3-dimensional tool radius compensation.

Set the value of "p" in the following formula.

$$V_x = i \times r/p, V_y = j \times r/p, V_z = k \times r/p$$

V_x, V_y, V_z : X, Y, and Z axes or vectors of horizontal axes

i, j, k : Program command value

r : Offset

$$p = \sqrt{(i^2 + j^2 + k^2)} \text{ when the set value is "0".}$$

---Setting range---

0 to 99999.999

【#8072】 SCALING P (for M system only)

Set the scale factor for reduction or magnification in the machining program specified by G50 or G51 command.

This parameter will be valid when the program specifies no scale factor.

---Setting range---

-99.999999 to 99.999999

【#8075】 SpiralEndErr (for M system only)

Set the tolerable error range (absolute value) when the end point position, commanded by the spiral or conical interpolation command with the command format type 2, differs from the end point position obtained from the speed and increment/decrement amount.

---Setting range---

0 to 99999.999 (mm)

【#8078】 Screen Saver Timer

Set the period of time before turn-OFF of the display unit backlight.

When "0" is set, the backlight is not turned OFF.

---Setting range---

0 to 60 (min)

0: The backlight is not turned OFF

【#8081】 Gcode Rotat (for L system only)

Set the rotation angle for the program coordinate rotation command.

This parameter is enabled when "1" is set in "#1270 ext06/bit5 (Coordinate rotation angle without command)".

This parameter is set as absolute value command regardless of the "#8082 G68.1 R INC" setting. If the rotation angle is designated by an address R in G68.1 command, the designation by program will be applied.

---Setting range---

-360.000 to +360.000 (°)

【#8082】 G68.1 R INC (for L system only)

Select absolute or increment command to use for the rotation angle command R at L-system coordinate rotation.

0: Use absolute value command in G90 modal, incremental value command in G91 modal

1: Always use incremental value command

(Note) If G91 does not exist in the G code system, the command type is decided by this parameter only.

【#8083】 G83S modeM (for M system only)

Set the M command code for changing to the small diameter deep hole drilling cycle mode.

---Setting range---

1 to 99999999

【#8084】 G83S Clearance (for M system only)

Set the clearance amount for the small diameter deep hole drilling cycle (G83).

---Setting range---
0 to 999.999 (mm)

【#8085】 G83S Forward F (for M system only)

Set the feedrate from the R point to the cutting start position in the small diameter deep hole drilling cycle (G83).

---Setting range---
0 to 99999 (mm/min)

【#8086】 G83S Back F (for M system only)

Set the speed for returning from the hole bottom during the small diameter deep hole drilling cycle (G83).

---Setting range---
0 to 99999 (mm/min)

【#8090】 SSS ON (for M system only)

Set whether to enable the SSS control with G05 P10000.
0: Disable
1: Enable

【#8091】 StdLength (for M system only)

Set the maximum value of the range for recognizing the shape.
To eliminate the effect of steps or errors, etc., set a large value. To enable sufficient deceleration, set a small value.
If "0.000" is set, the standard value (1.000mm) will be applied.

---Setting range---
0 to 100.000 (mm)

【#8092】 ClampCoeff (for M system only)

Set the clamp speed at the curved section configured of fine segments.
Coefficient = $\sqrt{\text{setting value}}$

---Setting range---
1 to 100

【#8093】 StepLeng (for M system only)

Set the width of the step at which the speed is not to be decelerated. (Approximately the same as the CAM path difference [Tolerance].)
If "0" is set, the standard value (5 μ m) will be applied.
If a minus value is set, the speed will decelerate at all minute steps.

---Setting range---
-1.000 to 0.100 (mm)

【#8094】 DccWaitAdd (for M system only)

Set the time to wait for deceleration when the speed FB does not drop to the clamp speed.

---Setting range---
0 to 100 (ms)

【#8101】 MACRO SINGLE

Select how to control the blocks where the user macro command continues.
0: Do not stop while macro blocks continue.
1: Stop every block during signal block operation.

【#8102】 COLL. ALM OFF

Select the interference (bite) control to the workpiece from the tool diameter during tool radius compensation and nose R compensation.

- 0: An alarm will be output and operation stops when an interference is judged.
- 1: Changes the path to avoid interference.

【#8103】 COLL. CHK OFF

Select the interference (bite) control to the workpiece from the tool diameter during tool radius compensation and nose R compensation.

- 0: Performs interference check.
- 1: Does not perform interference check.

【#8105】 EDIT LOCK B

Select the edit lock for program Nos. 8000 to 9999 in the memory.

- 0: Enable the editing.
- 1: Prohibit the editing of above programs.

When "1" is set, the file cannot be opened.

【#8106】 G46 NO REV-ERR (for L system only)

Select the control for the compensation direction reversal in G46 (nose R compensation).

- 0: An alarm will be output and operation will stop when the compensation direction is reversed (G41 -> G42' G42 -> G41).
- 1: An alarm won't occur when the compensation direction is reversed, and the current compensation direction will be maintained.

【#8107】 R COMPENSATION

Select whether to move to the inside because of a delay in servo response to a command during arc cutting mode.

- 0: Move to the inside, making the arc smaller than the command value.
- 1: Compensate the movement to the inside.

【#8108】 R COMP Select

Select the arc radius error compensation target.

- 0: Perform compensation over all axes.
- 1: Perform compensation axis by axis.

(Note) This parameter is effective only when "#8107 R COMPENSATION" is "1".

【#8109】 HOST LINK

Select whether to enable computer link B instead of the RS-232C port.

- 0: Disable (Enable normal RS-232C communication.)
- 1: Enable (Disable normal RS-232C communication.)

【#8110】 G71/G72 POCKET

Select whether to enable the pocket machining when there is a dimple (pocket) in the rough cutting cycle (G71, G72) finishing program.

- 0: OFF
- 1: ON

【#8111】 Milling Radius

Select the diameter and radius of the linear axis for milling (cylindrical/pole coordinate) interpolation.

- 0: All axes radius command
- 1: Each axis setting (follows "#1019 dia")

(Note) This parameter is valid only in the milling (cylindrical/polar coordinate) interpolation mode.

【#8112】 DECIMAL PNT-P

Select whether to enable the decimal point command for G04 address P.

- 0: Disable
- 1: Enable

【#8113】 Milling Init G16

Set which plane to execute for milling machining after the power is turned ON or reset.

#8113:0, #8114:0 ---> G17 plane
 #8113:0, #8114:1 ---> G19 plane
 #8113:1, #8114:0 ---> G16 plane
 #8113:1, #8114:1 ---> G16 plane

0: Not G16 plane
 1: G16 plane

(Note) This parameter is valid for the G code system 2 or 3 ("#1037 cmdtyp"="3" or "4").

【#8114】 Milling Init G19

Set which plane to execute for milling machining after the power is turned ON or reset.

#8113:0, #8114:0 ---> G17 plane
 #8113:0, #8114:1 ---> G19 plane
 #8113:1, #8114:0 ---> G16 plane
 #8113:1, #8114:1 ---> G16 plane

0: Not G19 plane
 1: G19 plane

(Note) This parameter is valid for the G code system 2 or 3 ("#1037 cmdtyp"="3" or "4").

【#8116】 Coord rot para invd

Select whether to enable the coordinate rotation by the parameters.

0: Enable
 1: Disable

【#8117】 OFS Diam DESIGN

Select tool radius or tool diameter compensation amount to be specified.

0: Tool radius compensation amount
 1: Tool diameter compensation amount

【#8119】 Comp. unit switch

Select the setting unit of compensation amount that has no decimal point.

0: 1mm (or 1inch) unit
 1: The minimum command unit (follows "#1003 iunit")

【#8120】 FONT SELECTION

Select the font when Simplified Chinese is selected for "#1043 lang".

0: MITSUBISHI CNC GOTHIC font
 1: Standard Windows font

(Note) This parameter is available for M700VW only.

【#8121】 Screen Capture

Select whether to enable the screen capture function.

0: Disable
 1: Enable

(Note 1) By setting this parameter to "1", and by keeping pushing the [SHIFT] key, screen capture will be executed.

(Note 2) This parameter is valid with M700VS/M70/M70V/E70 Series.

【#8122】 Keep G43 MDL M-REF

Select whether to keep the tool length offset by high speed manual reference position return during tool length offset.

0: Will not be kept (Cancel)
 1: Kept

【#8123】 H-spd retract ON

Select whether to enable the drilling cycle at high-speed retract in fixed cycle for drilling.

- 0: Disable
- 1: Enable

【#8124】 Mirr img at reset

Select the operation type of the mirror image by parameter setting and the mirror image by external input.

- 0: The current mirror image is canceled, and new mirror image will start with the machine position at reset as the mirror center.
- 1: The mirror center is kept to continue the mirror image.

【#8125】 Check Scode in G84

Select how to operate when there is no S command in synchronous tapping block.

- 0: Use the spindle function modal value as S-command value.
- 1: Output a program error.

【#8126】 Disable op tone

Select whether to disable keyboard/touch panel operation tones.

- 0: Enable the operation tones
- 1: Disable the operation tones

(Note) This setting is valid only for M700VS/M70V/M70/E70 Series.

【#8127】 R-Navi manu F coor

Select the initial value of the coordinate system for a manual feed while a machining surface is selected in the R-Navi function.

- 0: Feature coordinate system
- 1: Machine coordinate system

【#8129】 Subpro No. select

Select the subprogram No. to be called preferentially in subprogram control.

- 0: Commanded program No.
- 1: Four-digit program No. beginning with O No.
- 2: Eight-digit program No. beginning with O No.

(Note) The program to be called in user macro, figure rotation, macro interruption and compound type fixed cycle also follows this setting.

【#8135】 G5P4 single block

Single block stop is disabled during direct command mode.

- 0: Not disable single block stop
- 1: Disable single block stop

【#8145】 Validate F1 digit

Select whether to execute the F command with a 1-digit code command or with a direct numerical command.

(The same value as "#1079 F1digit" will be reflected. When either setting changes, the other will change accordingly.)

- 0: Direct numerical command (command feedrate during feed per minute or rotation)
- 1: 1-digit code command (with the feedrate specified by the parameters "#1185 spd_F1" to "#1189 spd_F5")

【#8154(PR)】

Not used. Set to "0".

【#8155】 Sub-pro interrupt

Select the method for the user macro interrupt.

(The same value as "#1229 set01/bit0" will be reflected. When either setting changes, the other will change accordingly.)

- 0: The user macro interrupt of macro type
- 1: The user macro interrupt of sub-program type

【#8156】 Fine thread cut E

Select the address E type when cutting an inch screw.
(The same value as "#1229 set01/bit1" will be reflected. When either setting changes, the other will change accordingly.)

- 0: Specify the number of threads per inch for inch screw cutting.
- 1: Specify the precision lead for inch screw cutting.

【#8157】 Radius comp type B (M system) / Nose R comp type B (L system)

For M system

Select the method of the arithmetic processing for the intersection point when the start-up or cancel commands are operated during radius compensation.

(The same value as "#1229 set01/bit2" will be reflected. When either setting changes, the other will change accordingly.)

- 0: The processing does not handle the start-up or cancel command block: handle the offset vector in the direction vertical to that of the command instead.
- 1: The processing is executed for the intersection point between the command block and the next block.

For L system

Select the method of the arithmetic processing for the intersection point when the start-up or cancel commands are operated during nose R or radius compensation.

(The same value as "#1229 set01/bit2" will be reflected. When either setting changes, the other will change accordingly.)

- 0: The processing does not handle the start-up or cancel command block: handle the offset vector in the direction vertical to that of the command instead.
- 1: The processing is executed for the intersection point between the command block and the next block.

【#8158】 Init const sur spd

Select the initial state after power-ON.

(The same value as "#1229 set01/bit3" will be reflected. When either setting changes, the other will change accordingly.)

- 0: Constant surface speed control cancel mode.
- 1: Constant surface speed control mode.

【#8159】 Synchronous tap

Select whether to use the floating tap chuck in G74 and G84 tap cycles.

(The same value as "#1229 set01/bit4" will be reflected. When either setting changes, the other will change accordingly.)

- 0: With a floating tapping chuck
- 1: Without a floating tapping chuck

【#8160】 Start point alarm

Select an operation when the operation start point cannot be found while moving to the next block of G117.

(The same value as "#1229 set01/bit5" will be reflected. When either setting changes, the other will change accordingly.)

- 0: The auxiliary function is enabled after the block for the movement has finished.
- 1: The program error (P33) occurs.

【#8173】 Hold intr amount

Select whether to clear or hold the interruption amount after the "NC reset 1 (or 2)" signal is ON when the manual ABS switch is OFF.

- 0: Clear (Reset the coordinate deviation due to the interruption)
- 1: Hold

【#8201】 AX. RELEASE

Select the function to remove the control axis from the control target.

- 0: Control as normal.
- 1: Remove from control target.

【#8202】 OT-CHECK OFF

Select whether to enable the stored stroke limit II function set in #8204 and #8205.

- 0: Enable
- 1: Disable

【#8203】 OT-CHECK-CANCEL

When the simple absolute position method ("#2049 type" is "9") is selected, the stored stroke limits I, II (or IIB) and IB can be disabled until the first reference position return is executed after the power is turned ON.

- 0: Enable (according to #8202)
- 1: Temporarily cancel

(Note) "#8203 OT-CHECK-CANCEL" affects all the stored stroke limits.

【#8204】 OT-CHECK-N

Set the coordinates of the (-) direction in the movable range of the stored stroke limit II or the lower limit coordinates of the prohibited range of stored stroke limit IIB.

If the sign and value are the same as #8205, the stored stroke limit II (or IIB) will be invalid.

If the stored stroke limit IIB function is selected, the prohibited range will be between two points even when #8204 and #8205 are set in reverse. When II is selected, the entire range will be prohibited if #8204 and #8205 are set in reverse.

---Setting range---

-99999.999 to 99999.999 (mm)

【#8205】 OT-CHECK-P

Set the coordinates of the (+) direction in the movable range of the stored stroke limit II or the upper limit coordinates of the prohibited range of stored stroke limit IIB.

---Setting range---

-99999.999 to 99999.999 (mm)

【#8206】 TOOL CHG. P

Set the coordinates of the tool change position for G30. n (tool change position return).
Set with coordinates in the basic machine coordinate system.

---Setting range---

-99999.999 to 99999.999 (mm)

【#8207】 G76/87 IGNR (for M system only)

Select whether to enable the shift operation at G76 (fine boring) and G87 (back boring).

- 0: Enable
- 1: Disable

【#8208】 G76/87 (-) (for M system only)

Select the shift direction at G76 and G87.

- 0: Shift to (+) direction
- 1: Shift to (-) direction

【#8209】 G60 SHIFT (for M system only)

Set the last positioning direction and distance for a G60 (unidirectional positioning) command.

---Setting range---

-99999.999 to 99999.999 (mm)

【#8210】 OT INSIDE

Select whether the stored stroke limit function set by #8204 and #8205 prevents the machine from moving to the inside or outside of the specified range.

- 0: Inhibits outside area (Select stored stroke limit II.)
- 1: Inhibits inside area (Select stored stroke limit II B.)

【#8211】 MIRR. IMAGE

Select whether to enable the parameter mirror image function.
 0: Disable
 1: Enable

【#8213(PR)】 Rotation axis type

Select the rotation type (short-cut valid/invalid) or linear type (workpiece coordinate linear type/all coordinate linear type).
 This parameter is enabled only when "#1017 rot" is set to "1". (Note)
 0: Short-cut invalid
 1: Short-cut valid
 2: Workpiece coordinate linear type
 3: All coordinate linear type

(Note) The movement method is as follows by the specified rotation axis type.

<Workpiece coordinate value>

0,1 : Display range 0° to 359.999°
 2,3 : Display range 0° to ±99999.999°

<Machine coordinate value/relative position>

0,1,2 : Display range 0° to 359.999°
 3 : Display range 0° to ±99999.999°

<ABS command>

0 : The incremental amount from the end point to the current position is divided by 360, and the axis moves by the remainder amount according to the sign.
 1 : Moves with a short-cut to the end point.
 2,3 : In the same manner as the normal linear axis, moves according to the sign by the amount obtained by subtracting the current position from the end point.

<INC command>

0,1,2,3 : Moves in the direction of the commanded sign by the commanded incremental amount starting at the current position.

<Reference position return>

0,1,2 : The movement to the middle point applies to the ABS command or the INC command. Returns with movement within 360 degrees from the middle point to reference position.
 3 : The movement to the middle point applies to the ABS command or the INC command. Moves and returns in the reference position direction for the difference from the current position to the reference position.

【#8215】 TLM std length

Set the TLM standard length.
 TLM standard length is the distance from a tool replacement point (reference position) to the measurement basic point (surface) which is used to measure the tool length.
 (The same value as "#2016 tlm+" will be reflected. When either setting changes, the other will change accordingly.)

---Setting range---

-99999.999 to 99999.999 (mm)

【#8216】 Type in G28 return

Select the performance after establishing the reference position in reference position return command.
 0: Moves to the reference position.
 1: Won't move to the reference position.

【#8217】 Check start point

Set a drawing start position in graphic check of each axis.

---Setting range---

-99999.999 to 99999.999 (mm)

【#8218】 Dir cmd retract amt

Set in which direction and how much the tool escapes when the operation is halted during direct command mode. (Radius value)
The tool does not escape when "0" is set.

---Setting range---

-99999.999 to 99999.999 (mm)

【#8219】 Hob retract amount 1

Set the retract amount using the radius value when the Hob retract amount selection signal is OFF. Retract is carried out in the negative direction if a negative value is set.

---Setting range---

-99999.999 to 99999.999 (mm)

【#8220】 Hob retract amount 2

Set the retract amount using the radius value when the Hob retract amount selection signal is ON. Retract is carried out in the negative direction if a negative value is set.

---Setting range---

-99999.999 to 99999.999 (mm)

【#8221】 Hob retract speed

Set the retract speed during hobbing.

---Setting range---

1 to 1000000 (mm/min)

【#8300】 P0 (for L system only)

Set the reference X-coordinates of the chuck and the tail stock barrier.
Set the center coordinate (radius value) of workpiece by the basic machine coordinate system.

---Setting range---

-99999.999 to 99999.999 (mm)

【#8301】 P1 (for L system only)

Set the area of the chuck and tail stock barrier.
Set the coordinate from the center of workpiece (P0) for X-axis. (radius value)
Set the coordinate value by basic machine coordinate system for Z-axis.

---Setting range---

-99999.999 to 99999.999 (mm)

【#8302】 P2 (for L system only)

Set the area of the chuck and tail stock barrier.
Set the coordinate from the center of workpiece (P0) for X-axis. (radius value)
Set the coordinate value by basic machine coordinate system for Z-axis.

---Setting range---

-99999.999 to 99999.999 (mm)

【#8303】 P3 (for L system only)

Set the area of the chuck and tail stock barrier.
Set the coordinate from the center of workpiece (P0) for X-axis. (radius value)
Set the coordinate value by basic machine coordinate system for Z-axis.

---Setting range---

-99999.999 to 99999.999 (mm)

【#8304】 P4 (for L system only)

Set the area of the chuck and tail stock barrier.
 Set the coordinate from the center of workpiece (P0) for X-axis. (radius value)
 Set the coordinate value by basic machine coordinate system for Z-axis.

---Setting range---
 -99999.999 to 99999.999 (mm)

【#8305】 P5 (for L system only)

Set the area of the chuck and tail stock barrier.
 Set the coordinate from the center of workpiece (P0) for X-axis. (radius value)
 Set the coordinate value by basic machine coordinate system for Z-axis.

---Setting range---
 -99999.999 to 99999.999 (mm)

【#8306】 P6 (for L system only)

Set the area of the chuck and tail stock barrier.
 Set the coordinate from the center of workpiece (P0) for X-axis. (radius value)
 Set the coordinate value by basic machine coordinate system for Z-axis.

---Setting range---
 -99999.999 to 99999.999 (mm)

【#8310】 Barrier ON (for L system only)

Select whether to enable the chuck and tailstock barrier.
 0: Disable (Setting from special display unit will be enabled)
 1: Enable

【#8311】 P7 (for L system only)

Set the area of the left spindle section.
 Set the coordinate from the center of workpiece (P0) for X-axis. (radius value)
 Set the coordinate value by basic machine coordinate system for Z-axis.

---Setting range---
 -99999.999 to 99999.999 (mm)

【#8312】 P8 (for L system only)

Set the area of the left spindle section.
 Set the coordinate from the center of workpiece (P0) for X-axis. (radius value)
 Set the coordinate value by basic machine coordinate system for Z-axis.

---Setting range---
 -99999.999 to 99999.999 (mm)

【#8313】 P9 (for L system only)

Set the area of the right spindle section.
 X axis: Set the coordinate from the workpiece center (P0). (radius value)
 Z axis: Set the coordinates in the basic machine coordinate system.

---Setting range---
 -99999.999 to 99999.999 (mm)

【#8314】 P10 (for L system only)

Set the area of the right spindle section.
 Set the coordinate from the center of workpiece (P0) for X-axis. (radius value)
 Set the coordinate value by basic machine coordinate system for Z-axis.

---Setting range---
 -99999.999 to 99999.999 (mm)

【#8315】 Barrier Type (L) (for L system only)

Select the shape of the left chuck and tailstock barrier.

- 0: No area
- 1: Chuck
- 2: Tailstock

【#8316】 Barrier Type (R) (for L system only)

Select the shape of the right chuck and tailstock barrier.

- 0: No area
- 1: Chuck
- 2: Tailstock

【#8317】 ELIV. AX. Name (for L system only)

Set the name of the delivery axis when the right chuck and tailstock barrier is movable.
When using the multi-part system method and the delivery axis is an axis in the other part system, designate the axis including the part system as 1A, 1B or 2A, 2B. If the part system is not designated as A and B, the set part system will be used.

---Setting range---

A/B/.. (axis name)

1A/1B/..

2A/2B/.. (with part system designated)

0: Cancel

【#8318】 Stock Angle (L) (for L system only)

Set the angle for the left tailstock end section.

The angle will be interpreted as 90° if there is no setting (when "0" is set).

---Setting range---

0 to 180 (°)

0: 90° (default)

【#8319】 Stock Angle (R) (for L system only)

Set the angle for the right tailstock end section.

The angle will be interpreted as 90° if there is no setting (when "0" is set).

---Setting range---

0 to 180 (°)

0: 90° (default)

【#8621】 Coord rot plane (H)

Set the plane (horizontal axis) for coordinate rotation control.

Usually, set the name of the 1st axis.

When this parameter is not set, the coordinate rotation function will not work.

---Setting range---

Axis name

【#8622】 Coord rot plane (V)

Set the plane (vertical axis) for coordinate rotation control.

Usually, set the name of the 2nd axis.

When this parameter is not set, the coordinate rotation function will not work.

---Setting range---

Axis name

【#8623】 Coord rot centr (H)

Set the center coordinates (horizontal axis) for coordinate rotation control.

---Setting range---

-999999.999 to 999999.999 (mm)

【#8624】 Coord rot centr (V)

Set the center coordinates (vertical axis) for coordinate rotation control.

---Setting range---
-999999.999 to 999999.999 (mm)

【#8625】 Coord rot vctr (H)

Set the vector components (horizontal axis) for coordinate rotation control.
When this parameter is set, the coordinate rotation control angle (#8627) will be automatically calculated.

---Setting range---
-999999.999 to 999999.999 (mm)

【#8626】 Coord rot vctr (V)

Set the vector components (vertical axis) for coordinate rotation control.
When this parameter is set, the coordinate rotation control angle (#8627) will be automatically calculated.

---Setting range---
-999999.999 to 999999.999 (mm)

【#8627】 Coord rot angle

Set the rotation angle for coordinate rotation control.
When this parameter is set, the coordinate rotation vector (#8625, #8626) will be "0".

---Setting range---
-360.000 to 360.000 (°)

【#8701】 Tool length

Set the length to the touch tool tip.

---Setting range---
-99999.999 to 99999.999 (mm)

【#8702】 Tool Dia

Set the diameter of the sphere at the touch tool tip.

---Setting range---
-99999.999 to 99999.999 (mm)

【#8703】 OFFSET X

This sets the deviation amount (X direction) from the touch tool center to the spindle center.

---Setting range---
-99999.999 to 99999.999 (mm)

【#8704】 OFFSET Y

Set the deviation amount (Y direction) from the touch tool center to the spindle center.

---Setting range---
-99999.999 to 99999.999 (mm)

【#8705】 RETURN

Set the one-time return distance for contacting again.

---Setting range---
0 to 99999.999 (mm)

【#8706】 FEED

Set the feedrate when contacting again.

---Setting range---

1 to 60000 (mm/min)

【#8707】 Skip past amount (H)

Set the difference (horizontal axis direction) between the skip read value and actual skip position.

---Setting range---

-99999.999 to 99999.999 (mm)

【#8708】 Skip past amount (V)

Set the difference (vertical axis direction) between the skip read value and actual skip position.

---Setting range---

-99999.999 to 99999.999 (mm)

【#8709】 EXT work sign rvs

Reverse the sign of external workpiece coordinate.

Select when using the external workpiece coordinate system with Z shift.

0: External workpiece offset without sign reversal

1: External workpiece offset with sign reversal

【#8710】 EXT work ofs invld

Set whether to enable external workpiece offset subtraction when setting the workpiece coordinate offset.

0: Not subtract the external workpiece offset. (Conventional specification)

1: Subtract the external workpiece offset.

【#8711】 TLM L meas axis

Set the tool length measurement axis.

Set the "#1022 axname2" axis name.

---Setting range---

Axis name

(Note) If the axis name is illegal or not set, the 3rd axis name will be set as default.

【#8712】 TLM D meas axis

Set the tool diameter measurement axis.

Set the "#1022 axname2" axis name.

---Setting range---

Axis name

(Note) If the axis name is illegal or not set, the 1st axis name will be set as default.

【#8713】 Skip coord. Switch (For M system only)

Select the coordinate system for reading skip coordinate value.

Select whether to read the skip coordinate in the workpiece coordinate system or in the feature coordinate system during inclined surface machining command.

Select whether to read the skip coordinate in the workpiece coordinate system or in the workpiece installation coordinate system during workpiece installation error compensation.

0: Workpiece coordinate system

1: Feature coordinate system/Workpiece installation coordinate system

【#8880】 Subpro stor D0: dev

Select the storage destination (device) for the subprogram.

M:Memory, G:HD(Note), F:FD(Note), R:Memory card, D:Data server(Note)
 (Note) This is available only with M700/M700VW Series.

When D0 is designated at a subprogram call, the subprogram to be called will be searched from the device selected with this parameter.

(Example) M98 P (program No.), D0
 -> Device: "#8880 Subpro stor D0: dev" device
 Directory: "#8881 Subpro stor D0: dir" directory
 The device and directory above will be searched.

(Note 1) When the called subprogram is not found in the selected storage destination, a program error will occur.

(Note 2) When D0 to D4 is not designated at a subprogram call, the subprogram will be searched from the memory.

【#8881】 Subpro stor D0: dir

Select the storage destination (directory) for the subprogram.

When D0 is designated at a subprogram call, the subprogram to be called will be searched from the directory selected with this parameter.

Refer to "#8880 Subpro stor D0: dev".

---Setting range---

Directory 48 characters

【#8882】 Subpro stor D1: dev

Select the storage destination (device) for the subprogram.

M:Memory, G:HD(Note), F:FD(Note), R:Memory card, D:Data server(Note)
 (Note) This is available only with M700/M700VW Series.

When D1 is designated at a subprogram call, the subprogram to be called will be searched from the device selected with this parameter.

(Example) M98 P (program No.), D1
 -> Device: "#8882 Subpro stor D1: dev" device
 Directory: "#8883 Subpro stor D1: dir" directory
 The device and directory above will be searched.

(Note 1) When the called subprogram is not found in the selected storage destination, a program error will occur.

(Note 2) When D0 to D4 is not designated at a subprogram call, the subprogram will be searched from the memory.

【#8883】 Subpro stor D1: dir

Select the storage destination (directory) for the subprogram.

When D1 is designated at a subprogram call, the subprogram to be called will be searched from the directory selected with this parameter.

Refer to "#8882 Subpro stor D1: dev".

---Setting range---

Directory 48 characters

【#8884】 Subbro stor D2: dev

Select the storage destination (device) for the subprogram.

M:Memory, G:HD(Note), F:FD(Note), R:Memory card, D:Data server(Note)
(Note) This is available only with M700/M700VW Series.

When D2 is designated at a subprogram call, the subprogram to be called will be searched from the device selected with this parameter.

(Example) M98 P (program No.), D2

-> Device: "#8884 Subbro stor D2: dev" device

Directory: "#8885 Subbro stor D2: dir" directory

The device and directory above will be searched.

(Note 1) When the called subprogram is not found in the selected storage destination, a program error will occur.

(Note 2) When D0 to D4 is not designated at a subprogram call, the subprogram will be searched from the memory.

【#8885】 Subbro stor D2: dir

Select the storage destination (directory) for the subprogram.

When D2 is designated at a subprogram call, the subprogram to be called will be searched from the directory selected with this parameter.

Refer to "#8884 Subbro stor D2: dev".

---Setting range---

Directory 48 characters

【#8886】 Subbro stor D3: dev

Select the storage destination (device) for the subprogram.

M:Memory, G:HD(Note), F:FD(Note), R:Memory card, D:Data server(Note)
(Note) This is available only with M700/M700VW Series.

When D3 is designated at a subprogram call, the subprogram to be called will be searched from the device selected with this parameter.

(Example) M98 P (program No.), D3

-> Device: "#8886 Subbro stor D3: dev" device

Directory: "#8887 Subbro stor D3: dir" directory

The device and directory above will be searched.

(Note 1) When the called subprogram is not found in the selected storage destination, a program error will occur.

(Note 2) When D0 to D4 is not designated at a subprogram call, the subprogram will be searched from the memory.

【#8887】 Subbro stor D3: dir

Select the storage destination (directory) for the subprogram.

When D3 is designated at a subprogram call, the subprogram to be called will be searched from the directory selected with this parameter.

Refer to "#8886 Subbro stor D3: dev".

---Setting range---

Directory 48 characters

【#8888】 Subpro stor D4: dev

Select the storage destination (device) for the subprogram.
 M:Memory, G:HD(Note), F:FD(Note), R:Memory card, D:Data server(Note)
 (Note) This is available only with M700/M700VW Series.

When D4 is designated at a subprogram call, the subprogram to be called will be searched from the device selected with this parameter.

(Example) M98 P (program No.), D4
 -> Device: "#8888 Subpro stor D4: dev" device
 Directory: "#8889 Subpro stor D4: dir" directory
 The device and directory above will be searched.

(Note 1) When the called subprogram is not found in the selected storage destination, a program error will occur.

(Note 2) When D0 to D4 is not designated at a subprogram call, the subprogram will be searched from the memory.

【#8889】 Subpro stor D4: dir

Select the storage destination (directory) for the subprogram.
 When D4 is designated at a subprogram calling, the subprogram to be called will be searched from the directory selected with this parameter.
 Refer to "#8888 Subpro stor D4: dev".

---Setting range---
 Directory 48 characters

【#8890-8894】 Subpro srch odr D0 to D4

Specify the search order of D0 to D4 (devices and directories storing subprograms) when D0 to D4 are omitted from subprogram call.
 Search is performed in the order from 1 to 5. When 0 is set, the device is excluded from search.
 If the same value is set for more than one device, search is carried out in the order from the one with a smaller parameter number.
 If 0 is set for all the devices, the memory is searched.

---Setting range---
 0 to 5

【#8901】 Counter type 1

Set the type of counter displayed at the upper left of the AUTO/MDI display on the Monitor screen.

- 1: Current position
- 2: Workpiece coordinate position
- 3: Machine position
- 4: Program position
- 8: Remain command
- 9: Manual interrupt amount
- 10: Next command
- 11: Restart position
- 12: Remain distance
- 16: Tip workpiece coordinate position
- 18: Tool axis movement
- 19: Tip machine position
- 20: Relative position
- 21: Table coordinate position
- 22: Workpiece installation position
- 23: Inclined surface coordinate

---Setting range---
 1 to 23

【#8902】 Counter type 2

Set the type of counter displayed at the lower left of the AUTO/MDI display on the Monitor screen.

- 1: Current position
- 2: Workpiece coordinate position
- 3: Machine position
- 4: Program position
- 8: Remain command
- 9: Manual interrupt amount
- 10: Next command
- 11: Restart position
- 12: Remain distance
- 16: Tip workpiece coordinate position
- 18: Tool axis movement
- 19: Tip machine position
- 20: Relative position
- 21: Table coordinate position
- 22: Workpiece installation position
- 23: Inclined surface coordinate

---Setting range---

1 to 23

【#8903】 Counter type 3

Set the type of counter displayed at the upper right of the AUTO/MDI display on the Monitor screen.

- 1: Current position
- 2: Workpiece coordinate position
- 3: Machine position
- 4: Program position
- 8: Remain command
- 9: Manual interrupt amount
- 10: Next command
- 11: Restart position
- 12: Remain distance
- 16: Tip workpiece coordinate position
- 18: Tool axis movement
- 19: Tip machine position
- 20: Relative position
- 21: Table coordinate position
- 22: Workpiece installation position
- 23: Inclined surface coordinate

---Setting range---

1 to 23

【#8904】 Counter type 4

Set the type of counter displayed at the lower right of the AUTO/MDI display on the Monitor screen.

- 1: Current position
- 2: Workpiece coordinate position
- 3: Machine position
- 4: Program position
- 8: Remain command
- 9: Manual interrupt amount
- 10: Next command
- 11: Restart position
- 12: Remain distance
- 16: Tip workpiece coordinate position
- 18: Tool axis movement
- 19: Tip machine position
- 20: Relative position
- 21: Table coordinate position
- 22: Workpiece installation position
- 23: Inclined surface coordinate

---Setting range---

1 to 23

【#8905】 Counter type 5

Set the type of counter displayed at the left of the Manual display on the Monitor screen.

- 1: Current position
- 2: Workpiece coordinate position
- 3: Machine position
- 4: Program position
- 8: Remain command
- 9: Manual interrupt amount
- 10: Next command
- 11: Restart position
- 12: Remain distance
- 16: Tip workpiece coordinate position
- 18: Tool axis movement
- 19: Tip machine position
- 20: Relative position
- 21: Table coordinate position
- 22: Workpiece installation position
- 23: Inclined surface coordinate

---Setting range---

1 to 23

【#8906】 Counter type 6

Set the type of counter displayed at the right of the Manual display on the Monitor screen.

- 1: Current position
- 2: Workpiece coordinate position
- 3: Machine position
- 4: Program position
- 8: Remain command
- 9: Manual interrupt amount
- 10: Next command
- 11: Restart position
- 12: Remain distance
- 16: Tip workpiece coordinate position
- 18: Tool axis movement
- 19: Tip machine position
- 20: Relative position
- 21: Table coordinate position
- 22: Workpiece installation position
- 23: Inclined surface coordinate

---Setting range---

1 to 23

【#8909(PR)】 Aut/Manual switch

Select the counter display method on Monitor screen.

- 0: "AUTO/MDI" and "Manual" display is switched by the mode selection switch.
- 1: Display AUTO/MDI counter only.
- 2: Display Manual counter only.
- 3: Display the enlarged counter of "#8901 Counter type 1".

(Note) This parameter is disabled when "#11019 2-system display (2-part system simultaneous display)" is set to "1" or "2".

【#8910】 Edit undo

Set whether to enable the Undo function during program edit on the Monitor screen or Edit screen.

- 0: Disable
- 1: Enable

(Note) This parameter is valid only with M700VW/M700VS/M700/M70V Series.

【#8913】 Touch panel sense

Set the sensibility of the touch panel.
 The smaller the setting value is, the more sensitive the panel will be.
 (1: sensitive, 4: insensitive)
 When set to 0, the sensibility will be the same as when the standard setting of 2 is applied.
 (Note) This parameter is available for M700VS/M70V/M70 Series.

---Setting range---
 0 to 4

【#8914】 Auto Top search

Select the operation method for restart search type 2.
 0: It is necessary to set the top search position arbitrarily.
 1: The restart search is executed from O No. that is designated as head.

【#8915】 Auto backup day 1

When the NC power is ON after the designated date was passed over, the automatic backup is executed.
 When "-1" is set to this parameter, the automatic backup is executed every turning NC power ON.
 When "0" is set to all on "Auto backup day 1" to "4", the automatic backup is not executed.
 It is possible to specify the designated date up to 4 days for a month.

---Setting range---
 -1 to 31

【#8916】 Auto backup day 2

When the NC power is ON after the designated date was passed over, the automatic backup is executed.
 When "-1" is set to "Auto backup day 1", the automatic backup is executed every turning NC power ON.
 When "0" is set to all on "Auto backup day 1" to "4", the automatic backup is not executed.
 It is possible to specify the designated date up to 4 days for a month.

---Setting range---
 0 to 31

【#8917】 Auto backup day 3

When the NC power is ON after the designated date was passed over, the automatic backup is executed.
 When "-1" is set to "Auto backup day 1", the automatic backup is executed every turning NC power ON.
 When "0" is set to all on "Auto backup day 1" to "4", the automatic backup is not executed.
 It is possible to specify the designated date up to 4 days for a month.

---Setting range---
 0 to 31

【#8918】 Auto backup day 4

When the NC power is ON after the designated date was passed over, the automatic backup is executed.
 When "-1" is set to "Auto backup day 1", the automatic backup is executed every turning NC power ON.
 When "0" is set to all on "Auto backup day 1" to "4", the automatic backup is not executed.
 It is possible to specify the designated date up to 4 days for a month.

---Setting range---
 0 to 31

【#8919】 Auto backup device

Select the automatic backup target device.

[M700/M700VW Series]

- 0: DS
- 1: HD
- 2: Memory card

[M700VS/M70V/E70 Series]

- 0: Memory card
- 3: USB memory

[M70 Series]

- 0: Memory card

(Note) The setting range differs according to the model.

【#8920】 3D tool ofs select

Select the method to calculate the drawing position when drawing a solid.

With 3D drawing, the drawing position (tool tip position) is calculated with the method designated with this parameter, and the image is drawn.

- 0: For tool radius compensation, use the tool compensation amount set in tool compensation screen. For tool length, use the value in tool set window. (for tool length measurement type I)
- 1: Use the tool compensation amount set in tool compensation screen for both tool radius and tool length compensation. (for tool length measurement type II)
- 2: Use the value set in tool set window for both tool radius and tool length compensation. (for tool length measurement type I)
- 3: Use the value set in tool set window for both tool radius and tool length compensation. (for tool length measurement type II)

【#8921】 Mass Edit select

Select the editing mode for the machining programs saved in HD, FD, and memory card.

When the program size is 1.0MB (When "#8910 Edit Undo" is invalid, 2.0MB) or more, mass-editing will be applied.

- 0: Regular editing mode
- 1: Mass-editing mode

【#8922】 T-reg-dup check

Set whether to enable the duplication check in registering tools to magazine pots, and in setting tool Nos. for spindle/standby.

- 0: Duplication check valid for all valid magazines
- 1: Duplication check invalid
- 2: Duplication check valid only for the selected magazine

【#8923(PR)】 Hide Edit-IO menu

Set whether to enable the edit-in/out menu. When disabled, the edit-input/output menu won't appear. However, the maintenance-in/out menu is always enabled regardless of this parameter setting.

- 0: Enable
- 1: Disable

【#8924】 MEAS. CONFIRM MSG

Select whether to display a confirming message when attempting to write compensation data for tool measurement, or coordinate system data for workpiece measurement.

However, the confirmation message will not appear in L system tool measurement simple mode "#8957 T meas (L)-Simple".

- 0: Not display a confirming message
- 1: Display a confirming message

【#8925】 SP on 1st part sys

Set a spindle No. to be displayed on the 1st part system window when 2-part system simultaneous display is valid. On the 15-type display, 1-part system display can be also specified.

High-order: Select an upper side spindle No.

Low-order: Select a lower side spindle No.

(Note 1) When "00" is set in 2-part system simultaneous display, spindles will be displayed in a default order (the 1st spindle on the upper side, the 2nd spindle on the lower side). When "00" is set in 1-part system display of the 15-type display, all spindles will be displayed.

(Note 2) If you designate a bigger number than the setting of "#1039 spinno", or either the high-order or low-order setting is "0", the 1st spindle will be displayed.

(Note 3) If the low-order is set to "F", the spindle speed command value and the actual rotation number which are specified in the high-order will be displayed.

---Setting range---

High-order: 0 to 6

Low-order: 0 to 6, F

【#8926】 SP on 2nd part sys

Set a spindle No. to be displayed on the 2nd part system window when 2-part system simultaneous display is valid. On the 15-type display, 1-part system display can be also specified.

High-order: Select an upper side spindle No.

Low-order: Select a lower side spindle No.

(Note 1) When "00" is set in 2-part system simultaneous display, spindles will be displayed in a default order (the 1st spindle on the upper side, the 2nd spindle on the lower side). When "00" is set in 1-part system display of the 15-type display, all spindles will be displayed.

(Note 2) If you designate a bigger number than the setting of "#1039 spinno", or either the high-order or low-order setting is "0", the 1st spindle will be displayed.

(Note 3) If the low-order is set to "F", the spindle speed command value and the actual rotation number which are specified in the high-order will be displayed.

---Setting range---

High-order: 0 to 6

Low-order: 0 to 6, F

【#8927】 SP on 3rd part sys

Set a spindle No. to be displayed on the 3rd part system window when 2-part system simultaneous display is valid. On the 15-type display, 1-part system display can be also specified.

High-order: Select an upper side spindle No.

Low-order: Select a lower side spindle No.

(Note 1) When "00" is set in 2-part system simultaneous display, spindles will be displayed in a default order (the 1st spindle on the upper side, the 2nd spindle on the lower side). When "00" is set in 1-part system display of the 15-type display, all spindles will be displayed.

(Note 2) If you designate a bigger number than the setting of "#1039 spinno", or either the high-order or low-order setting is "0", the 1st spindle will be displayed.

(Note 3) If the low-order is set to "F", the spindle speed command value and the actual rotation number which are specified in the high-order will be displayed.

---Setting range---

High-order: 0 to 6

Low-order: 0 to 6, F

【#8928】 SP on 4th part sys

Set a spindle No. to be displayed on the 4th part system window when 2-part system simultaneous display is valid. On the 15-type display, 1-part system display can be also specified.

High-order: Select an upper side spindle No.

Low-order: Select a lower side spindle No.

(Note 1) When "00" is set in 2-part system simultaneous display, spindles will be displayed in a default order (the 1st spindle on the upper side, the 2nd spindle on the lower side). When "00" is set in 1-part system display of the 15-type display, all spindles will be displayed.

(Note 2) If you designate a bigger number than the setting of "#1039 spinno", or either the high-order or low-order setting is "0", the 1st spindle will be displayed.

(Note 3) If the low-order is set to "F", the spindle speed command value and the actual rotation number which are specified in the high-order will be displayed.

---Setting range---

High-order: 0 to 6

Low-order: 0 to 6, F

【#8929】 Disable=INPUT:comp

Select whether to enable [=INPUT] menu in [T-ofs] (tool compensation amount setting) or [Coord] (workpiece coordinate system offset setting) menu on [Setup] screen.

0: Enable

1: Disable

【#8930】 Disable=INPUT:var

Select whether to enable [=INPUT] menu in [Com var] (common variables) menu on [Monitr] screen.

0: Enable

1: Disable

【#8931】 Display/Set limit

Select the restriction of the connected NC's screen display/settings on/from the remote control tool.

0: Permit the screen display/settings

1: Permit the screen display only

2: Restrict the connection

【#8932(PR)】 Hide measure scrn

Select whether to display the tool measurement screen and workpiece measurement screen.

0: Display

1: Not display

【#8933】 Disable lngth comp

Set whether to disable the setting of tool shape compensation amount.

0: Not disable

1: Disable

The shape compensation amount covers the following data according to the tool compensation type.

- Compensation type I ("1" in "#1037 cmdtyp(command type)")
 - ... Compensation amount (the sum of shape compensation and wear compensation amount)
- Compensation type II ("2" in "#1037 cmdtyp(command type)")
 - ... Length dimension and radius dimension
- Compensation type III ("3" in "#1037 cmdtyp(command type)")
 - ... Tool length and tool nose R

【#8934】 Disable wear comp

Select whether to disable the setting of tool wear compensation amount.

- 0: Not disable
- 1: Disable

The wear compensation amount covers the following data according to the tool compensation type.

- Compensation type I ("1" in "#1037 cmdtyp(command type 1)")
... This parameter is disabled.
- Compensation type II ("2" in "#1037 cmdtyp(command type)")
... Length wear and radius wear
- Compensation type III ("3" in "#1037 cmdtyp(command type)")
... Tool wear and tool nose wear

【#8935】 W COORD CONFIRM

Select whether to display confirmation message when setting workpiece coordinate system offset in [Simple setting] menu.

- 0: Not display
- 1: Display

【#8936】 Delete leading 0

In creating a file, or in transferring a file, if the file name of the new file, or the file name of the transfer destination consists only of numerical figures, 0 of the file name head will be deleted from the name.

- 0: Designated file name (0 remains in the file name)
- 1: 0 will be deleted from the file name

【#8937】 File sort volume

Set the maximum number of files to sort in the memory card and DS lists.

If the setting is large, update of the list may take longer.

With M70V/M70/E70 Series, the maximum number will be 64 regardless of the setting of this parameter.

---Setting range---

- 64 to 1000(M700/M700VW Series)
- 64 to 250(M700VS Series)
- Standard: 64

【#8938】 Edit-Not show Prg

Select whether to enable the automatic display on the Edit screen, when selected, of the programs searched by operation/check search or the MDI programs in MDI mode.

- 0: Enable the automatic display
- 1: Disable the automatic display

【#8939】 Undo confirm msg

Display a confirming message when operating the [Undo] menu.

- 0: Not display a confirming message
- 1: Display a confirming message

【#8940】 Set select display

Select what to display in the selectable display area.

- 0: Common variable
- 1: Local variable
- 2: Workpiece coordinate system offset
- 3: All spindles' rotation speed
- 4: Expanded counters
- 5: Tool center coordinate display
- 6: Custom release window

(Note 1) This parameter is available for 15-type display unit only.

(Note 2) Tool center coordinate display is available only when any of the 5-axis related options is enabled.

【#8941(PR) ABS/INC for T-ofs

Enable switching the method to set tool compensation data (absolute/incremental value) with INPUT key.
 0: Fix it to the absolute value input.
 1: Enable to switch between absolute and incremental value input.

【#8942(PR) \$1 color

Set the color to be shown on the top-left of screen for the 1st part system. This enables switching the color patterns for each part system.
 When set to the values 1 to 4, the part system name is shown in the form of button image.
 When set to 0, the settings between #8943 and #8945 is disabled and the screen is shown by the default color pattern for all the part systems.
 0: Purple (no button image) (default)
 1: Purple
 2: Pink
 3: Light blue
 4: Orange

【#8943(PR) \$2 color

Set the color to be shown on the top-left of screen for the 2nd part system. This enables switching the color patterns for each part system. When set to the values 1 to 4, the part system name is shown in the form of button image.
 Note) Enabled when #8942 (\$1 color) is set to the values 1 to 4.
 1: Purple (default)
 2: Pink
 3: Light blue
 4: Orange

【#8944(PR) \$3 color

Set the color to be shown on the top-left of screen for the 3rd part system. This enables switching the color patterns for each part system. When set to the values 1 to 4, the part system name is shown in the form of button image.
 Note) Enabled when #8942 (\$1 color) is set to the values 1 to 4.
 1: Purple (default)
 2: Pink
 3: Light blue
 4: Orange

【#8945(PR) \$4 color

Set the color to be shown on the top-left of screen for the 4th part system. This enables switching the color patterns for each part system. When set to the values 1 to 4, the part system name is shown in the form of button image.
 Note) Enabled when #8942 (\$1 color) is set to the values 1 to 4.
 1: Purple (default)
 2: Pink
 3: Light blue
 4: Orange

【#8951] No Tab counter sw.

Disable Tab key to change the counter type.
 0: Enable Tab key to change counter typ
 (The value of #8905 also changes)
 1: Disable Tab key to change counter type

【#8952] Edit-win \$ switch

Select whether to enable switching of program displayed in the edit window on Monitor screen according to the displayed part system when part system switch is performed.
 0: Not switch
 1: Switch

【#8953】 2\$ disp switch typ

Select how to switch the part system to display when the 2-part system simultaneous display is enabled.

- 0: Switch by incrementing the No. of part system to display by one.
- 1: Switch by skipping the system displayed in the non-active area. When a window is being popped up, however, this skip is not performed and the system is switched by incrementing the No. by one.

【#8954】 Initial type

Select the default setting of the coordinate axis direction designation method to be displayed on the [Surface detail] screen of R-Navi.

- 0,1: Point (+) on the axis
- 2: Latitude/Longitude
- 3: Latitude/Projection angle
- 4: Start point/End point
- 5: Index angle

【#8955】 Init axis pair

Select the default coordinate axis combination to be displayed on the [Surface detail] screen of R-Navi.

- 0,1: Z/X
- 2: Z/Y
- 3: X/Y

【#8956(PR)】 User key type

Select the definition type of the user-defined keys.

There are two user-defined keys.

Type 1 :

It is the same as the conventional specification. A line feed between "[]" is not dealt as ";".
It is dealt as an upper case/lower case letter depending on the CapsLock status.

A symbolic character may be converted into a specific character.

Type 2:

A line break inside square brackets "[]" is dealt as ";".

Regardless of the CapsLock status, the defined character is input.

A symbolic character is also input as defined.

0 : Type 1 (Conventional specification)

1 : Type 2

(Note) This parameter is valid for M700VW series.

【#8957(PR)】 T meas (L)-Simple

Select the operation mode of the manual tool length measurement 1 for L system.

0: Normal operation mode (Conventional specification)

Select an axis to measure using the cursor position.

1: Simple operation mode

Select an axis to measure using an axis address key or menu.

More than one axis can be selected.

【#9001】 DATA IN PORT

Select the port for inputting the data such as machine program and parameters.

1: ch1

2: ch2

【#9002】 DATA IN DEV.

Select the device No. for inputting the data. (The device Nos. correspond to the input/output device parameters.)

---Setting range---

0 to 4

【#9003】 DATA OUT PORT

Select the port for outputting the data such as machine program and parameters.
 1: ch1
 2: ch2

【#9004】 DATA OUT DEV.

Select the device No. for outputting the data. (The device Nos. correspond to the input/output device parameters.)

---Setting range---
 0 to 4

【#9005】 TAPE MODE PORT

Select the input port for running with the tape mode.
 1: ch1
 2: ch2

【#9006】 TAPE MODE DEV.

Select the device No. to be run with the tape mode. (The device Nos. correspond to the input/output device parameters.)

---Setting range---
 0 to 4

【#9007】 MACRO PRINT PORT

Select the output port used for the user macro DPRINT command.
 1: ch1
 2: ch2
 9: Memory card

【#9008】 MACRO PRINT DEV.

Select the device No. used for the DPRINT command. (The device Nos. correspond to the input/output device parameters.)

---Setting range---
 0 to 4

【#9009】 PLC IN/OUT PORT

Select the port for inputting/outputting various data with PLC.
 1: ch1
 2: ch2

【#9010】 PLC IN/OUT DEV.

Select the device No. used for the PLC input/output. (The device Nos. correspond to the input/output device parameters.)

---Setting range---
 0 to 4

【#9011】 REMOTE PRG IN PORT

Select the port for inputting remote programs.
 1: ch1
 2: ch2

【#9012】 REMOTE PRG IN DEV.

Select the device No. used to input remote programs. The device Nos. correspond to the input/output device parameters.

---Setting range---
 0 to 4

【#9013】 EXT UNIT PORT

Select the port for communication with an external unit.

- 1: ch1
- 2: ch2

【#9014】 EXT UNIT DEV.

Select the unit No. used for communication with an external unit(The unit Nos. correspond to the input/output device parameters.)

- Setting range---**
0 to 4

【#9017】 HANDY TERMINAL PORT

Select the port for communication with a handy terminal.

- 1: ch1
- 2: ch2

【#9018】 HANDY TERMINAL DEV.

Select the device No. used for communication with a handy terminal. (The device Nos. correspond to the input/output device parameters.)

- Setting range---**
0 to 4

【#9051】 Data I/O port

Select whether to use display side serial port or NC side serial port for data input/output function.

- 0: Display side serial port
- 1: Display side serial port
- 2: NC side serial port

(Note) The setting range differs according to the model.

【#9052】 Tape mode port

Select whether to use display side serial port or NC side serial port for tape mode.

- 0: NC side serial port
- 1: Display side serial port
- 2: NC side serial port

(Note) The setting range differs according to the model.

【#9053】 M2 macro converter

Select whether to enable the macro converter when inputting M2/M0 formatted program via RS-232C (serial connection).

When enabling the converter, select whether to convert the comment part enclosed with brackets ().

- 0: Disable
- 1: Enable; convert the comment part enclosed with brackets ().
- 2: Enable; not convert the comment part enclosed with brackets ().

【#9054】 MACRO PRINT FILE

Set the file name to save the output data to a memory card with the DRPNT command for the user macro.

If this parameter is not set, the data will be output under the following name.

dprt\$-MMDDhhmmssff

\$ is the part system No. in which DPRNT is commanded, MMDDhhmmssff is the current date. (MM: month, DD: day, hh: hour, mm: minute, ss: second, ff: millisecond)

(Note) This parameter is enabled when "#9007 Macro print directory" is set to "9".

- Setting range---**
Program name or file name (32 characters)

【#9101】 DEV0 DEVICE NAME

Set the device name corresponding to the device No.
Set a simple name for quick identification.

---Setting range---

Use alphabet characters, numerals and symbols to set a name within 3 characters.

【#9102】 DEV0 BAUD RATE

Select the serial communication speed.

- 0: 19200 (bps)
- 1: 9600
- 2: 4800
- 3: 2400
- 4: 1200
- 5: 600
- 6: 300
- 7: 110

【#9103】 DEV0 STOP BIT

Select the stop bit length used in the start-stop system.

Refer to "#9104 DEV0 PARITY CHECK". At the output of data, the number of characters is always adjusted for the parity check.

- 1: 1 (bit)
- 2: 1.5
- 3: 2

【#9104】 DEV0 PARITY CHECK

Select whether to add the parity check bit to the data.

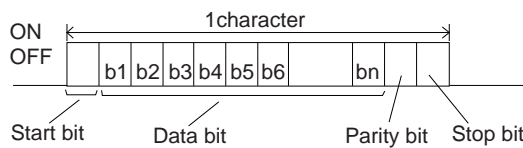

Set this parameter in accordance with the I/O device specifications.

- 0: Not add a parity bit in I/O mode
- 1: Add a parity bit in I/O mode

【#9105】 DEV0 EVEN PARITY

Select odd or even when parity is added to the data. This parameter is ignored when no parity is added.

- 0: Odd parity
- 1: Even parity

【#9106】 DEV0 CHR. LENGTH

Set the length of the data bit.

Refer to "#9104 DEV0 PARITY CHECK".

- 0: 5 (bit)
- 1: 6
- 2: 7 (NC connection not supported)
- 3: 8

【#9107】 DEV0 TERMINATR TYP

Select the code to terminate data reading.

- 0, 3: EOR
 - 1, 2: EOB or EOR
- [When M700/700VW display side serial port is selected]
- 0: No terminator
 - 1: EOR
 - 2: EOB
 - 3: EOB or EOR

【#9108】 DEV0 HAND SHAKE

Select the transmission control method.
 No handshaking will be used when a value except 1 to 3 is set.

- 1: RTS/CTS method
- 2: No handshaking
- 3: DC code method

【#9109】 DEV0 DC CODE PRY

Select the DC code type when the DC code method is selected.

- 0: Not add parity to DC code (DC3 = 13H)
- 1: Add parity to DC code (DC3 = 93H)

【#9111】 DEV0 DC2/4 OUTPUT

Select the DC code handling when outputting data to the output device.

DC2 / DC4

- 0: None / None
- 1: Yes / None
- 2: None / Yes
- 3: Yes / Yes

【#9112】 DEV0 CR OUTPUT

Select whether to add the (CR) code just before the EOB (L/F) code during output.

- 0: Not add
- 1: Add

【#9113】 DEV0 EIA OUTPUT

Select ISO or EIA code for data output.
 In data input mode, the ISO and EIA codes are identified automatically.

- 0: ISO code output
- 1: EIA code output

【#9114】 DEV0 FEED CHR.

Set the length of the tape feed to be output at the start and end of the data during tape output.

---Setting range---
 0 to 999 (characters)

【#9115】 DEV0 PARITY V

Select whether to perform the parity check for the number of characters in a block at the input of data.
 At the output of data, the number of characters is always adjusted to for the parity check.

- 0: Not perform parity V check
- 1: Perform parity V check

【#9116】 DEV0 TIME-OUT (sec)

Set the time out time to detect an interruption in communication.
 Time out check will not be executed when set to "0".

---Setting range---
 0 to 30 (s)

【#9117】 DEV0 DR OFF

Select whether to enable the DR data check in data I/O mode.

- 0: Enable
- 1: Disable

【#9118】 DEV0 DATA ASCII

Select the code of the output data.

- 0: ISO/EIA code (Depends on whether #9113, #9213, #9313, #9413 or #9513 EIA output parameter is set up.)
- 1: ASCII code

【#9119】 DEVO INPUT TYPE

Select the mode for input (verification).

- 0: Standard input (Data from the very first EOB is handled as significant information.)
- 1: EOBs following the first EOB of the input data are skipped until data other than EOB is input

【#9120】 DEVO OUT BUFFER

Select the buffer size of the output data which is output to output device using NC side serial port. If the output device has a data receiving error (overrun error), decrease the buffer size with this parameter.

If the buffer size is decreased, output time will prolong according to the size.

- 0: 250 bytes (default)
- 1: 1 byte
- 2: 4 bytes
- 3: 8 bytes
- 4: 16 bytes
- 5: 64 bytes

【#9121】 DEVO EIA CODE [

Set the code in hexadecimal, which does not duplicate the existing EIA codes, for the special code "[".

When output with EIA code, data can be output using the alternate code in which the special ISO code, not included in EIA, is specified.

---Setting range---

0 to FF (hexadecimal)

【#9122】 DEVO EIA CODE]

Set the code in hexadecimal, which does not duplicate the existing EIA codes, for the special code "]".

When output with EIA code, data can be output using the alternate code in which the special ISO code, not included in EIA, is specified.

---Setting range---

0 to FF (hexadecimal)

【#9123】 DEVO EIA CODE #

Set the code in hexadecimal, which does not duplicate the existing EIA codes, for the special code "#".

When output with EIA code, data can be output using the alternate code in which the special ISO code, not included in EIA, is specified.

---Setting range---

0 to FF (hexadecimal)

【#9124】 DEVO EIA CODE *

Set the code in hexadecimal, which does not duplicate the existing EIA codes, for the special code "*".

When output with EIA code, data can be output using the alternate code in which the special ISO code, not included in EIA, is specified.

---Setting range---

0 to FF (hexadecimal)

【#9125】 DEVO EIA CODE =

Set the code in hexadecimal, which does not duplicate the existing EIA codes, for the special code "=".

When output with EIA code, data can be output using the alternate code in which the special ISO code, not included in EIA, is specified.

---Setting range---

0 to FF (hexadecimal)

【#9126】 DEV0 EIA CODE :

Set the code in hexadecimal, which does not duplicate the existing EIA codes, for the special code ":".

When output with EIA code, data can be output using the alternate code in which the special ISO code, not included in EIA, is specified.

---Setting range---

0 to FF (hexadecimal)

【#9127】 DEV0 EIA CODE \$

Set the code in hexadecimal, which does not duplicate the existing EIA codes, for the special code "\$".

When output with EIA code, data can be output using the alternate code in which the special ISO code, not included in EIA, is specified.

---Setting range---

0 to FF (hexadecimal)

【#9128】 DEV0 EIA CODE !

Set the code in hexadecimal, which does not duplicate the existing EIA codes, for the special code "!".

When output with EIA code, data can be output using the alternate code in which the special ISO code, not included in EIA, is specified.

---Setting range---

0 to FF (hexadecimal)

【#9201】 DEV1 DEVICE NAME

Set the device name corresponding to the device No.

Set a simple name for quick identification.

---Setting range---

Use alphabet characters, numerals and symbols to set a name within 3 characters.

【#9202】 DEV1 BAUD RATE

Select the serial communication speed.

0: 19200 (bps)

1: 9600

2: 4800

3: 2400

4: 1200

5: 600

6: 300

7: 110

【#9203】 DEV1 STOP BIT

Select the stop bit length used in the start-stop system.

Refer to "#9204 DEV1 PARITY CHECK". At the output of data, the number of characters is always adjusted to for the parity check.

1: 1 (bit)

2: 1.5

3: 2

【#9204】 DEV1 PARITY CHECK

Select whether to add a parity check bit to the data.

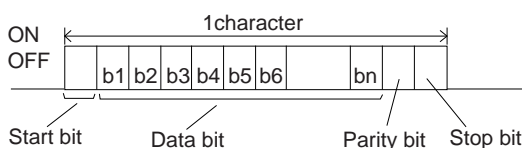

Set this parameter in accordance with the I/O device specifications.

0: Not add a parity bit in I/O mode

1: Add a parity bit in I/O mode

【#9205】 DEV1 EVEN PARITY

Select whether even or odd parity will be used when parity is used. This parameter is ignored when no parity is added.

- 0: Odd parity
- 1: Even parity

【#9206】 DEV1 CHR. LENGTH

Select the length of the data bit.
Refer to "#9204 DEV1 PARITY CHECK".

- 0: 5 (bit)
- 1: 6
- 2: 7 (NC connection not supported)
- 3: 8

【#9207】 DEV1 TERMINATR TYP

Select the code to terminate data reading.

- 0, 3: EOR
 - 1, 2: EOB or EOR
- [When M700/700VW display side serial port is selected]
- 0: No terminator
 - 1: EOR
 - 2: EOB
 - 3: EOB or EOR

【#9208】 DEV1 HAND SHAKE

Select the transmission control method.

No handshaking will be used when a value except 1 to 3 is set.

- 1: RTS/CTS method
- 2: No handshaking
- 3: DC code method

【#9209】 DEV1 DC CODE PRTY

Select the DC code type when the DC code method is selected.

- 0: Not add parity to DC code (DC3 = 13H)
- 1: Add parity to DC code (DC3 = 93H)

【#9211】 DEV1 DC2/4 OUTPUT

Select the DC code handling when outputting data to the output device.

- DC2 / DC4
- 0: None / None
- 1: Yes / None
- 2: None / Yes
- 3: Yes / Yes

【#9212】 DEV1 CR OUTPUT

Select whether to add the (CR) code just before the EOB (L/F) code during output.

- 0: Not add
- 1: Add

【#9213】 DEV1 EIA OUTPUT

Select ISO or EIA code for data output.

In data input mode, the ISO and EIA codes are identified automatically.

- 0: ISO code output
- 1: EIA code output

【#9214】 DEV1 FEED CHR.

Set the length of the tape feed to be output at the start and end of the data during tape output.

---Setting range---

- 0 to 999 (characters)

【#9215】 DEV1 PARITY V

Select whether to perform the parity check for the number of characters in a block at the input of data.

At the output of data, the number of characters is always adjusted to for the parity check.

- 0: Not perform parity V check
- 1: Perform parity V check

【#9216】 DEV1 TIME-OUT (sec)

Set the time out time to detect an interruption in communication.

Time out check will not be executed when set to "0".

---Setting range---

0 to 30 (s)

【#9217】 DEV1 DR OFF

Select whether to enable the DR data check in data I/O mode.

- 0: Enable
- 1: Disable

【#9218】 DEV1 DATA ASCII

Select the code of the output data.

- 0: ISO/EIA code (Depends on whether #9113, #9213, #9313, #9413 or #9513 EIA output parameter is set up.)
- 1: ASCII code

【#9219】 DEV1 INPUT TYPE

Select the mode for input (verification).

- 0: Standard input (Data from the very first EOB is handled as significant information.)
- 1: EOBs following the first EOB of the input data are skipped until data other than EOB is input

【#9220】 DEV1 OUT BUFFER

Select the buffer size of the output data which is output to output device using NC side serial port. If the output device has a transmission error (overrun error), decrease the buffer size with this parameter.

If the buffer size is decreased, output time will prolong according to the size.

- 0: 250 bytes (default)
- 1: 1 byte
- 2: 4 byte
- 3: 8 byte
- 4: 16 byte
- 5: 64 byte

【#9221】 DEV1 EIA CODE [

Set the code in hexadecimal, which does not duplicate the existing EIA codes, for the special code "[

". When output with EIA code, data can be output using the alternate code in which the special ISO code, not included in EIA, is specified.

---Setting range---

0 to FF (hexadecimal)

【#9222】 DEV1 EIA CODE]

Set the code in hexadecimal, which does not duplicate the existing EIA codes, for the special code "]"

". When output with EIA code, data can be output using the alternate code in which the special ISO code, not included in EIA, is specified.

---Setting range---

0 to FF (hexadecimal)

【#9223】 DEV1 EIA CODE #

Set the code in hexadecimal, which does not duplicate the existing EIA codes, for the special code "#".

When output with EIA code, data can be output using the alternate code in which the special ISO code, not included in EIA, is specified. .

---Setting range---

0 to FF (hexadecimal)

【#9224】 DEV1 EIA CODE *

Set the code in hexadecimal, which does not duplicate the existing EIA codes, for the special code "*".

When output with EIA code, data can be output using the alternate code in which the special ISO code, not included in EIA, is specified.

---Setting range---

0 to FF (hexadecimal)

【#9225】 DEV1 EIA CODE =

Set the code in hexadecimal, which does not duplicate the existing EIA codes, for the special code "=".

When output with EIA code, data can be output using the alternate code in which the special ISO code, not included in EIA, is specified.

---Setting range---

0 to FF (hexadecimal)

【#9226】 DEV1 EIA CODE :

Set the code in hexadecimal, which does not duplicate the existing EIA codes, for the special code ":".

When output with EIA code, data can be output using the alternate code in which the special ISO code, not included in EIA, is specified.

---Setting range---

0 to FF (hexadecimal)

【#9227】 DEV1 EIA CODE \$

Set the code in hexadecimal, which does not duplicate the existing EIA codes, for the special code "\$".

When output with EIA code, data can be output using the alternate code in which the special ISO code, not included in EIA, is specified.

---Setting range---

0 to FF (hexadecimal)

【#9228】 DEV1 EIA CODE !

Set the code in hexadecimal, which does not duplicate the existing EIA codes, for the special code "!".

When output with EIA code, data can be output using the alternate code in which the special ISO code, not included in EIA, is specified.

---Setting range---

0 to FF (hexadecimal)

【#9301】 DEV2 DEVICE NAME

Set the device name corresponding to the device No.

Set a simple name for quick identification.

---Setting range---

Use alphabet characters, numerals and symbols to set a name within 3 characters.

【#9302】 DEV2 BAUD RATE

Select the serial communication speed.

- 0: 19200 (bps)
- 1: 9600
- 2: 4800
- 3: 2400
- 4: 1200
- 5: 600
- 6: 300
- 7: 110

【#9303】 DEV2 STOP BIT

Select the stop bit length used in the start-stop system.

Refer to "#9304 DEV2 PARITY CHECK". At the output of data, the number of characters is always adjusted to for the parity check.

- 1: 1 (bit)
- 2: 1.5
- 3: 2

【#9304】 DEV2 PARITY CHECK

Select whether to add a parity check bit to the data.

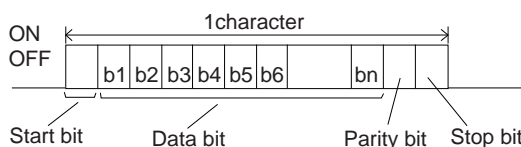

Set this parameter in accordance with the I/O device specifications.

- 0: Not add a parity bit in I/O mode
- 1: Add a parity bit in I/O mode

【#9305】 DEV2 EVEN PARITY

Select whether even or odd parity will be used when parity is used. This parameter is ignored when no parity is added.

- 0: Odd parity
- 1: Even parity

【#9306】 DEV2 CHR. LENGTH

Select the length of the data bit.

Refer to "#9304 DEV2 PARITY CHECK".

- 0: 5 (bit)
- 1: 6
- 2: 7 (NC connection not supported)
- 3: 8

【#9307】 DEV2 TERMINATR TYP

Select the code to terminate data reading.

- 0, 3: EOR
- 1, 2: EOB or EOR
- [When M700/700VW display side serial port is selected]
- 0: No terminator
- 1: EOR
- 2: EOB
- 3: EOB or EOR

【#9308】 DEV2 HAND SHAKE

Select the transmission control method.

No handshaking will be used when a value except 1 to 3 is set.

- 1: RTS/CTS method
- 2: No handshaking
- 3: DC code method

【#9309】 DEV2 DC CODE PRTY

Select the DC code type when the DC code method is selected.
 0: Not add parity to DC code (DC3 = 13H)
 1: Add parity to DC code (DC3 = 93H)

【#9311】 DEV2 DC2/4 OUTPUT

Select the DC code handling when outputting data to the output device.
 DC2 / DC4
 0: None / None
 1: Yes / None
 2: None / Yes
 3: Yes / Yes

【#9312】 DEV2 CR OUTPUT

Select whether to add the (CR) code just before the EOB (L/F) code during output.
 0: Not add
 1: Add

【#9313】 DEV2 EIA OUTPUT

Select ISO or EIA code for data output.
 In data input mode, the ISO and EIA codes are identified automatically.
 0: ISO code output
 1: EIA code output

【#9314】 DEV2 FEED CHR.

Set the length of the tape feed to be output at the start and end of the data during tape output.

---Setting range---
 0 to 999 (characters)

【#9315】 DEV2 PARITY V

Select whether to perform the parity check for the number of characters in a block at the input of data.
 At the output of data, the number of characters is always adjusted to for the parity check.
 0: Not perform parity V check
 1: Perform parity V check

【#9316】 DEV2 TIME-OUT (sec)

Set the time out time to detect an interruption in communication.
 Time out check will not be executed when set to "0".

---Setting range---
 0 to 30 (s)

【#9317】 DEV2 DR OFF

Select whether to enable the DR data check in data I/O mode.
 0: Enable
 1: Disable

【#9318】 DEV2 DATA ASCII

Select the code of the output data.
 0: ISO/EIA code (Depends on whether #9113, #9213, #9313, #9413 or #9513 EIA output parameter is set up.)
 1: ASCII code

【#9319】 DEV2 INPUT TYPE

Select the mode for input (verification).
 0: Standard input (Data from the very first EOB is handled as significant information.)
 1: EOBs following the first EOB of the input data are skipped until data other than EOB is input

【#9320】 DEV2 OUT BUFFER

Select the buffer size of the output data which is output to output device using NC side serial port. If the output device has a transmission error (overrun error), decrease the buffer size with this parameter.

If the buffer size is decreased, output time will prolong according to the size.

- 0: 250 bytes (default)
- 1: 1 byte
- 2: 4 byte
- 3: 8 byte
- 4: 16 byte
- 5: 64 byte

【#9321】 DEV2 EIA CODE [

Set the code in hexadecimal, which does not duplicate the existing EIA codes, for the special code "[".

When output with EIA code, data can be output using the alternate code in which the special ISO code, not included in EIA, is specified.

---Setting range---

0 to FF (hexadecimal)

【#9322】 DEV2 EIA CODE]

Set the code in hexadecimal, which does not duplicate the existing EIA codes, for the special code "]".

When output with EIA code, data can be output using the alternate code in which the special ISO code, not included in EIA, is specified.

---Setting range---

0 to FF (hexadecimal)

【#9323】 DEV2 EIA CODE #

Set the code in hexadecimal, which does not duplicate the existing EIA codes, for the special code "#".

When output with EIA code, data can be output using the alternate code in which the special ISO code, not included in EIA, is specified.

---Setting range---

0 to FF (hexadecimal)

【#9324】 DEV2 EIA CODE *

Set the code in hexadecimal, which does not duplicate the existing EIA codes, for the special code "*".

When output with EIA code, data can be output using the alternate code in which the special ISO code, not included in EIA, is specified.

---Setting range---

0 to FF (hexadecimal)

【#9325】 DEV2 EIA CODE =

Set the code in hexadecimal, which does not duplicate the existing EIA codes, for the special code "=".

When output with EIA code, data can be output using the alternate code in which the special ISO code, not included in EIA, is specified.

---Setting range---

0 to FF (hexadecimal)

【#9326】 DEV2 EIA CODE :

Set the code in hexadecimal, which does not duplicate the existing EIA codes, for the special code ":".

When output with EIA code, data can be output using the alternate code in which the special ISO code, not included in EIA, is specified.

---Setting range---

0 to FF (hexadecimal)

【#9327】 DEV2 EIA CODE \$

Set the code in hexadecimal, which does not duplicate the existing EIA codes, for the special code "\$".
 When output with EIA code, data can be output using the alternate code in which the special ISO code, not included in EIA, is specified.

---Setting range---
 0 to FF (hexadecimal)

【#9328】 DEV2 EIA CODE !

Set the code in hexadecimal, which does not duplicate the existing EIA codes, for the special code "!".
 When output with EIA code, data can be output using the alternate code in which the special ISO code, not included in EIA, is specified.

---Setting range---
 0 to FF (hexadecimal)

【#9401】 DEV3 DEVICE NAME

Set the device name corresponding to the device No.
 Set a simple name for quick identification.

---Setting range---
 Use alphabet characters, numerals and symbols to set a name within 3 characters.

【#9402】 DEV3 BAUD RATE

Select the serial communication speed.
 0: 19200 (bps)
 1: 9600
 2: 4800
 3: 2400
 4: 1200
 5: 600
 6: 300
 7: 110

【#9403】 DEV3 STOP BIT

Select the stop bit length used in the start-stop system.
 Refer to "#9404 DEV3 PARITY CHECK". At the output of data, the number of characters is always adjusted to for the parity check.
 1: 1 (bit)
 2: 1.5
 3: 2

【#9404】 DEV3 PARITY CHECK

Select whether to add a parity check bit to the data.

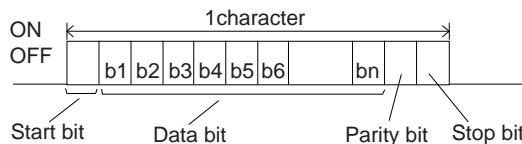

Set this parameter in accordance with the I/O device specifications.
 0: Not add a parity bit in I/O mode
 1: Add a parity bit in I/O mode

【#9405】 DEV3 EVEN PARITY

Select whether even or odd parity will be used when parity is used. This parameter is ignored when no parity is added.
 0: Odd parity
 1: Even parity

【#9406】 DEV3 CHR. LENGTH

Select the length of the data bit.
 Refer to "#9404 DEV3 PARITY CHECK".
 0: 5 (bit)
 1: 6
 2: 7 (NC connection not supported)
 3: 8

【#9407】 DEV3 TERMINATR TYP

Select the code to terminate data reading.
 0, 3: EOR
 1, 2: EOB or EOR
 [When M700/700VW display side serial port is selected]
 0: No terminator
 1: EOR
 2: EOB
 3: EOB or EOR

【#9408】 DEV3 HAND SHAKE

Select the transmission control method.
 No handshaking will be used when a value except 1 to 3 is set.
 1: RTS/CTS method
 2: No handshaking
 3: DC code method

【#9409】 DEV3 DC CODE PRTY

Select the DC code type when the DC code method is selected.
 0: Not add parity to DC code (DC3 = 13H)
 1: Add parity to DC code (DC3 = 93H)

【#9411】 DEV3 DC2/4 OUTPUT

Select the DC code handling when outputting data to the output device.
 DC2 / DC4
 0: None / None
 1: Yes / None
 2: None / Yes
 3: Yes / Yes

【#9412】 DEV3 CR OUTPUT

Select whether to add the (CR) code just before the EOB (L/F) code during output.
 0: Not add
 1: Add

【#9413】 DEV3 EIA OUTPUT

Select ISO or EIA code for data output.
 In data input mode, the ISO and EIA codes are identified automatically.
 0: ISO code output
 1: EIA code output

【#9414】 DEV3 FEED CHR.

Set the length of the tape feed to be output at the start and end of the data during tape output.
 ---Setting range---
 0 to 999 (characters)

【#9415】 DEV3 PARITY V

Select whether to perform the parity check for the number of characters in a block at the input of data.
 At the output of data, the number of characters is always adjusted to for the parity check.
 0: Not perform parity V check
 1: Perform parity V check

【#9416】 DEV3 TIME-OUT (sec)

Set the time out time to detect an interruption in communication.
Time out check will not be executed when set to "0".

---Setting range---

0 to 30 (s)

【#9417】 DEV3 DR OFF

Select whether to enable the DR data check in data I/O mode.

0: Enable
1: Disable

【#9418】 DEV3 DATA ASCII

Select the code of the output data.

0: ISO/EIA code (Depends on whether #9113, #9213, #9313, #9413 or #9513 EIA output parameter is set up.)
1: ASCII code

【#9419】 DEV3 INPUT TYPE

Select the mode for input (verification).

0: Standard input (Data from the very first EOB is handled as significant information.)
1: EOBs following the first EOB of the input data are skipped until data other than EOB is input.

【#9420】 DEV3 OUT BUFFER

Select the buffer size of the output data which is output to output device using NC side serial port.
If the output device has a data receiving error (overrun error), decrease the buffer size with this parameter.

If the buffer size is decreased, output time will prolong according to the size.

0: 250 bytes (default)
1: 1 byte
2: 4 bytes
3: 8 bytes
4: 16 bytes
5: 64 bytes

【#9421】 DEV3 EIA CODE [

Set the code in hexadecimal, which does not duplicate the existing EIA codes, for the special code "[".

When output with EIA code, data can be output using the alternate code in which the special ISO code, not included in EIA, is specified.

---Setting range---

0 to FF (hexadecimal)

【#9422】 DEV3 EIA CODE]

Set the code in hexadecimal, which does not duplicate the existing EIA codes, for the special code "]".

When output with EIA code, data can be output using the alternate code in which the special ISO code, not included in EIA, is specified.

---Setting range---

0 to FF (hexadecimal)

【#9423】 DEV3 EIA CODE #

Set the code in hexadecimal, which does not duplicate the existing EIA codes, for the special code "#".

When output with EIA code, data can be output using the alternate code in which the special ISO code, not included in EIA, is specified.

---Setting range---

0 to FF (hexadecimal)

【#9424】 DEV3 EIA CODE *

Set the code in hexadecimal, which does not duplicate the existing EIA codes, for the special code "*".

When output with EIA code, data can be output using the alternate code in which the special ISO code, not included in EIA, is specified.

---Setting range---

0 to FF (hexadecimal)

【#9425】 DEV3 EIA CODE =

Set the code in hexadecimal, which does not duplicate the existing EIA codes, for the special code "=".

When output with EIA code, data can be output using the alternate code in which the special ISO code, not included in EIA, is specified.

---Setting range---

0 to FF (hexadecimal)

【#9426】 DEV3 EIA CODE :

Set the code in hexadecimal, which does not duplicate the existing EIA codes, for the special code ":".

When output with EIA code, data can be output using the alternate code in which the special ISO code, not included in EIA, is specified.

---Setting range---

0 to FF (hexadecimal)

【#9427】 DEV3 EIA CODE \$

Set the code in hexadecimal, which does not duplicate the existing EIA codes, for the special code "\$".

When output with EIA code, data can be output using the alternate code in which the special ISO code, not included in EIA, is specified.

---Setting range---

0 to FF (hexadecimal)

【#9428】 DEV3 EIA CODE !

Set the code in hexadecimal, which does not duplicate the existing EIA codes, for the special code "!".

When output with EIA code, data can be output using the alternate code in which the special ISO code, not included in EIA, is specified.

---Setting range---

0 to FF (hexadecimal)

【#9501】 DEV4 DEVICE NAME

Set the device name corresponding to the device No.

Set a simple name for quick identification.

---Setting range---

Use alphabet characters, numerals and symbols to set a name within 3 characters.

【#9502】 DEV4 BAUD RATE

Select the serial communication speed.

0: 19200 (bps)

1: 9600

2: 4800

3: 2400

4: 1200

5: 600

6: 300

7: 110

【#9503】 DEV4 STOP BIT

Select the stop bit length used in the start-stop system.
Refer to "#9504 DEV4 PARITY CHECK". At the output of data, the number of characters is always adjusted to for the parity check.

- 1: 1 (bit)
- 2: 1.5
- 3: 2

【#9504】 DEV4 PARITY CHECK

Select whether to add a parity check bit to the data.

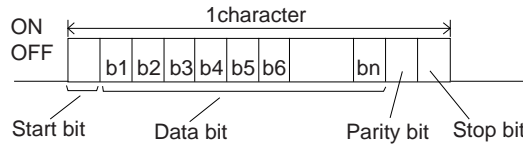

Set this parameter in accordance with the I/O device specifications.

- 0: Not add a parity bit in I/O mode
- 1: Add a parity bit in I/O mode

【#9505】 DEV4 EVEN PARITY

Select whether even or odd parity will be used when parity is used. This parameter is ignored when no parity is added.

- 0: Odd parity
- 1: Even parity

【#9506】 DEV4 CHR. LENGTH

Select the length of the data bit.
Refer to "#9504 DEV4 PARITY CHECK".

- 0: 5 (bit)
- 1: 6
- 2: 7 (NC connection not supported)
- 3: 8

【#9507】 DEV4 TERMINATR TYP

Select the code to terminate data reading.

- 0, 3: EOR
 - 1, 2: EOB or EOR
- [When M700/700VW display side serial port is selected]
- 0: No terminator
 - 1: EOR
 - 2: EOB
 - 3: EOB or EOR

【#9508】 DEV4 HAND SHAKE

Select the transmission control method.

No handshaking will be used when a value except 1 to 3 is set.

- 1: RTS/CTS method
- 2: No handshaking
- 3: DC code method

【#9509】 DEV4 DC CODE PRTY

Select the DC code type when the DC code method is selected.

- 0: Not add parity to DC code (DC3 = 13H)
- 1: Add parity to DC code (DC3 = 93H)

【#9511】 DEV4 DC2/4 OUTPUT

Select the DC code handling when outputting data to the output device.

- DC2 / DC4
- 0: None / None
- 1: Yes / None
- 2: None / Yes
- 3: Yes / Yes

【#9512】 DEV4 CR OUTPUT

Select whether to add the (CR) code just before the EOB (L/F) code during output.

- 0: Not add
- 1: Add

【#9513】 DEV4 EIA OUTPUT

Select ISO or EIA code for data output.

In data input mode, the ISO and EIA codes are identified automatically.

- 0: ISO code output
- 1: EIA code output

【#9514】 DEV4 FEED CHR.

Set the length of the tape feed to be output at the start and end of the data during tape output.

---Setting range---

- 0 to 999 (characters)

【#9515】 DEV4 PARITY V

Select whether to perform the parity check for the number of characters in a block at the input of data.

At the output of data, the number of characters is always adjusted to for the parity check.

- 0: Not perform parity V check
- 1: Perform parity V check

【#9516】 DEV4 TIME-OUT (sec)

Set the time out time to detect an interruption in communication.

Time out check will not be executed when set to "0".

---Setting range---

- 0 to 30 (s)

【#9517】 DEV4 DR OFF

Select whether to enable the DR data check in data I/O mode.

- 0: Enable
- 1: Disable

【#9518】 DEV4 DATA ASCII

Select the code of the output data.

- 0: ISO/EIA code (Depends on whether #9113, #9213, #9313, #9413 or #9513 EIA output parameter is set up.)
- 1: ASCII code

【#9519】 DEV4 INPUT TYPE

Select the mode for input (verification).

- 0: Standard input (Data from the very first EOB is handled as significant information.)
- 1: EOBs following the first EOB of the input data are skipped until data other than EOB is input.

【#9520】 DEV4 OUT BUFFER

Select the buffer size of the output data which is output to output device using NC side serial port. If the output device has a transmission error (overrun error), decrease the buffer size with this parameter.

If the buffer size is decreased, output time will prolong according to the size.

- 0: 250 bytes (default)
- 1: 1 byte
- 2: 4 byte
- 3: 8 byte
- 4: 16 byte
- 5: 64 byte

【#9521】 DEV4 EIA CODE [

Set the code in hexadecimal, which does not duplicate the existing EIA codes, for the special code "[".
When output with EIA code, data can be output using the alternate code in which the special ISO code, not included in EIA, is specified.

---Setting range---

0 to FF (hexadecimal)

【#9522】 DEV4 EIA CODE]

Set the code in hexadecimal, which does not duplicate the existing EIA codes, for the special code "]".
When output with EIA code, data can be output using the alternate code in which the special ISO code, not included in EIA, is specified.

---Setting range---

0 to FF (hexadecimal)

【#9523】 DEV4 EIA CODE #

Set the code in hexadecimal, which does not duplicate the existing EIA codes, for the special code "#".
When output with EIA code, data can be output using the alternate code in which the special ISO code, not included in EIA, is specified.

---Setting range---

0 to FF (hexadecimal)

【#9524】 DEV4 EIA CODE *

Set the code in hexadecimal, which does not duplicate the existing EIA codes, for the special code "*".
When output with EIA code, data can be output using the alternate code in which the special ISO code, not included in EIA, is specified.

---Setting range---

0 to FF (hexadecimal)

【#9525】 DEV4 EIA CODE =

Set the code in hexadecimal, which does not duplicate the existing EIA codes, for the special code "=".
When output with EIA code, data can be output using the alternate code in which the special ISO code, not included in EIA, is specified.

---Setting range---

0 to FF (hexadecimal)

【#9526】 DEV4 EIA CODE :

Set the code in hexadecimal, which does not duplicate the existing EIA codes, for the special code ":".
When output with EIA code, data can be output using the alternate code in which the special ISO code, not included in EIA, is specified.

---Setting range---

0 to FF (hexadecimal)

【#9527】 DEV4 EIA CODE \$

Set the code in hexadecimal, which does not duplicate the existing EIA codes, for the special code "\$".
When output with EIA code, data can be output using the alternate code in which the special ISO code, not included in EIA, is specified.

---Setting range---

0 to FF (hexadecimal)

【#9528】 DEV4 EIA CODE !

Set the code in hexadecimal, which does not duplicate the existing EIA codes, for the special code "!".

When output with EIA code, data can be output using the alternate code in which the special ISO code, not included in EIA, is specified.

---Setting range---

0 to FF (hexadecimal)

【#9601】 BAUD RATE

Select the rate at which data is transferred.

0: 19200 (bps)

1: 9600

2: 4800

3: 2400

4: 1200

5: 600

6: 300

7: 110

8: 38400

【#9602】 STOP BIT

Select the stop bit length used in the start-stop system.

Refer to "#9603 PARITY EFFECTIVE". At the output of data, the number of characters is always adjusted to for the parity check.

1: 1 (bit)

2: 1.5

3: 2

【#9603】 PARITY EFFECTIVE

Select whether to add the parity bit to the data.

The parameter is set when using a parity bit separately from the data bit.

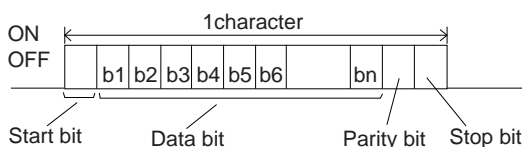

Set this parameter according to the specifications of input/output device.

0: Not add a parity bit at the input/output

1: Add a parity bit at the input/output

【#9604】 EVEN PARITY

Select odd or even when parity is added to the data. This parameter is ignored when no parity is added.

0: Odd parity

1: Even parity

【#9605】 CHR. LENGTH

Select the length of the data bit.

Refer to "#9603 PARITY EFFECTIVE".

0: 5 (bit)

1: 6

2: 7 (NC connection not supported)

3: 8

【#9606】 HAND SHAKE

Select the transmission control method.

"3" (DC code method) should be set for computer link B.

0: No control

1: RTS/CTS method

2: No handshaking

3: DC code method

【#9607】 TIME-OUT SET

Set the time-out time at which an interruption of data transfer during data input/output should be detected.

"0" means infinite time-out.

---Setting range---

0 to 999 (1/10s)

【#9608】 DATA CODE

Set the code to be used for the data description.

Refer to "#9603 PARITY EFFECTIVE".

0: ASCII code

1: ISO code

【#9609】 LINK PARAM. 1**bit1: DC1 output after NAK or SYN**

Select whether to output the DC1 code after the NAK or SYN code is output.

0: Not output the DC1 code.

1: Output the DC1 code.

bit7: Enable/disable resetting

Select whether to enable the resetting in the computer link.

0: Enable

1: Disable

【#9610】 LINK PARAM. 2**Bit 2: Specify the control code parity (even parity for the control code).**

Select whether to add an even parity to the control code, in accordance with the I/O device specifications.

0: Not add a parity bit to the control code

1: Add a parity bit to the control code

Bit 3: Parity V

Select whether to enable checking of parity V in one block at the input of the data.

0: Disable

1: Enable

【#9611】 Link PARAM. 3

Not used. Set to "0".

【#9612】 Link PARAM. 4

Not used. Set to "0".

【#9613】 Link PARAM. 5

Not used. Set to "0".

【#9614】 START CODE

Select the code used to command the first transfer of file data.

This parameter is used for a specific user. Normally set "0".

0: DC1 (11H)

1: BEL (07H)

【#9615】 CTRL. CODE OUT**bit 0: NAK output**

Select whether to send the NAK code to the host if a communication error occurs in computer link B.
 0: Not output the NAK code
 1: Output the NAK code.

bit 1: SYN output

Select whether to send the SYN code to the host if NC resetting or an emergency stop occurs in computer link B.
 0: Not output the SYN code.
 1: Output the SYN code.

bit 3: DC3 output

Select whether to send the DC3 code to the host when the communication ends in computer link B.
 0: Not output the DC3 code.
 1: Output the DC3 code.

【#9616】 CTRL. INTERVAL

Not used. Set to "0".

【#9617】 WAIT TIME

Not used. Set to "0".

【#9618】 PACKET LENGTH

Not used. Set to "0".

【#9619】 BUFFER SIZE

Not used. Set to "0".

【#9620】 START SIZE

Not used. Set to "0".

【#9621】 DC1 OUT SIZE

Not used. Set to "0".

【#9622】 POLLING TIMER

Not used. Set to "0".

【#9623】 TRANS. WAIT TMR

Not used. Set to "0".

【#9624】 RETRY COUNTER

Not used. Set to "0".

【#9701(PR)】 IP addr auto set

The IP address is automatically assigned from the server.

0: Manual setting
 1: Automatic setting

(Note) When the automatic setting is selected, "#11005 PC IP address, PC Subnet, PC Gateway" will be invalid.

【#9706】 Host No.

Select the No. of the host to be used from host 1 to host 4.

---Setting range---
 1 to 4 : Host No.

【#9711】 Host1 host name

Set the host computer name.
 This parameter allows the NC to easily recognize the host computer on the network. Set the host computer's name (name registered in C:\windows\hosts) or the IP address.

<Setting example>

For host name: mspc160
 For IP address: 150.40.0.111

(Note) Set the host computer's TCP/IP address if communication is not carried out correctly.

---Setting range---

15 characters (alphanumeric) or less

【#9712】 Host1 user name

Set the user name when logging into the host computer.

---Setting range---

15 characters (alphanumeric) or less

【#9713】 Host1 password

Set the password when logging into the host computer.

---Setting range---

15 characters (alphanumeric) or less

【#9714】 Host1 directory

Set the directory name of the host computer.
 The directory released to the client (NC unit) with the host computer's server is handled as root directory by the NC unit.

---Setting range---

31 characters (alphanumeric) or less

【#9715】 Host1 host type

Select the type of the host computer.

- 0: UNIX/PC automatic judgment
- 1: UNIX
- 2: PC (DOS)

(Note) When "0" is set, the settings for the following parameters will be invalid.

- #9716 Wrd pos: name
- #9717 Wrd pos: size
- #9718 Wrd pos: Dir
- #9719 Wrd pos: cmnt
- #9720 Wrd num: cmnt

【#9716】 Host 1 Wrd pos: name

Set the file name display position (nth word from left) of the list displayed when the ftp command "dir" is executed.

(Note) One word designates a character string divided by one or more spaces.

---Setting range---

0 to 100
 0: Default value

【#9717】 Host 1 Wrd pos: size

Set the size display position (nth word from left) of the list displayed when the ftp command "dir" is executed.

(Note) One word designates a character string divided by one or more spaces.

---Setting range---

0 to 100
0: Default value

【#9718】 Host 1 Wrd pos: Dir

Set the <DIR> display position (nth word from left) of the list displayed when the ftp command "dir" is executed.

(Note) One word designates a character string divided by one or more spaces.

---Setting range---

0 to 100
0: Default value

【#9719】 Host 1 Wrd pos: cmnt

Set the comment (date, time, etc.) display position (nth word from left) of the list displayed when the ftp command "dir" is executed.

(Note) One word designates a character string divided by one or more spaces.

---Setting range---

0 to 100
0: Default value

【#9720】 Host 1 Wrd num: cmnt

Set the number of words to be displayed as a comment.

(Note) One word designates a character string divided by one or more spaces.

---Setting range---

0 to 100
0: Default value

【#9721】 Host 1 no total siz

Set whether to display the total number of characters registered in the machining programs of host1 when displaying the file list.

If there are many files in the directory to be referred to, the list can be updated quickly by setting "1".

0: Display
1: Not display

【#9731】 Host2 host name

Set the host computer name.

This parameter allows the NC to easily recognize the host computer on the network. Set the host computer's name (name registered in C:\windows\hosts) or the IP address.

<Setting example>

For host name: mspc160

For IP address: 150.40.0.111

(Note) Set the host computer's TCP/IP address if communication is not carried out correctly.

---Setting range---

15 characters (alphanumeric) or less

【#9732】 Host2 user name

Set the user name when logging into the host computer.

---Setting range---

15 characters (alphanumeric) or less

【#9733】 Host2 password

Set the password when logging into the host computer.

---Setting range---

15 characters (alphanumeric) or less

【#9734】 Host2 directory

Set the directory name of the host computer.

The directory released to the client (NC unit) with the host computer's server is handled as the root directory by the NC unit.

---Setting range---

31 characters (alphanumeric) or less

【#9735】 Host2 host type

Select the type of the host computer.

- 0: UNIX/PC automatic judgment
- 1: UNIX
- 2: PC (DOS)

(Note) When "0" is set, the settings for the following parameters will be invalid.

- #9736 Wrd pos: name
- #9737 Wrd pos: size
- #9738 Wrd pos: Dir
- #9739 Wrd pos: cmnt
- #9740 Wrd num: cmnt

【#9736】 Host 2 Wrd pos: name

Set the file name display position (nth word from left) of the list displayed when the ftp command "dir" is executed.

(Note) One word designates a character string divided by one or more spaces.

---Setting range---

- 0 to 100
- 0: Default value

【#9737】 Host 2 Wrd pos: size

Set the size display position (nth word from left) of the list displayed when the ftp command "dir" is executed.

(Note) One word designates a character string divided by one or more spaces.

---Setting range---

- 0 to 100
- 0: Default value

【#9738】 Host 2 Wrd pos: Dir

Set the <DIR> display position (nth word from left) of the list displayed when the ftp command "dir" is executed.

(Note) One word designates a character string divided by one or more spaces.

---Setting range---

- 0 to 100
- 0: Default value

【#9739】 Host 2 Wrd pos: cmnt

Set the comment (date, time, etc.) display position (nth word from left) of the list displayed when the ftp command "dir" is executed.

(Note) One word designates a character string divided by one or more spaces.

---Setting range---

0 to 100

0: Default value

【#9740】 Host 2 Wrd num: cmnt

Set the number of words to be displayed as a comment.

(Note) One word designates a character string divided by one or more spaces.

---Setting range---

0 to 100

0: Default value

【#9741】 Host 2 no total siz

Set whether to display the total number of characters registered in the machining programs of host1 when displaying the file list.

If there are many files in the directory to be referred to, the list can be updated quickly by setting "1".

0: Display

1: Not display

【#9751】 Host3 host name

Set the host computer name.

This parameter allows the NC to easily recognize the host computer on the network. Set the host computer's name (name registered in C:\windows\hosts) or the IP address.

<Setting example>

For host name: mspc160

For IP address: 150.40.0.111

(Note) Set the host computer's TCP/IP address if communication is not carried out correctly.

---Setting range---

15 characters (alphanumeric) or less

【#9752】 Host3 user name

Set the user name when logging into the host computer.

---Setting range---

15 characters (alphanumeric) or less

【#9753】 Host3 password

Set the password when logging into the host computer.

---Setting range---

15 characters (alphanumeric) or less

【#9754】 Host3 directory

Set the directory name of the host computer.

The directory released to the client (NC unit) with the host computer's server is handled as the root directory by the NC unit.

---Setting range---

31 characters (alphanumeric) or less

【#9755】 Host3 host type

Select the type of the host computer.

- 0: UNIX/PC automatic judgment
- 1: UNIX
- 2: PC (DOS)

(Note) When "0" is set, the settings for the following parameters will be invalid.

- #9756 Wrd pos: name
- #9757 Wrd pos: size
- #9758 Wrd pos: Dir
- #9759 Wrd pos: cmnt
- #9760 Wrd num: cmnt

【#9756】 Host 3 Wrd pos: name

Set the file name display position (nth word from left) of the list displayed when the ftp command "dir" is executed.

(Note) One word designates a character string divided by one or more spaces.

---Setting range---

- 0 to 100
- 0: Default value

【#9757】 Host 3 Wrd pos: size

Set the size display position (nth word from left) of the list displayed when the ftp command "dir" is executed.

(Note) One word designates a character string divided by one or more spaces.

---Setting range---

- 0 to 100
- 0: Default value

【#9758】 Host 3 Wrd pos: Dir

Set the <DIR> display position (nth word from left) of the list displayed when the ftp command "dir" is executed.

(Note) One word designates a character string divided by one or more spaces.

---Setting range---

- 0 to 100
- 0: Default value

【#9759】 Host 3 Wrd pos: cmnt

Set the comment (date, time, etc.) display position (nth word from left) of the list displayed when the ftp command "dir" is executed.

(Note) One word designates a character string divided by one or more spaces.

---Setting range---

- 0 to 100
- 0: Default value

【#9760】 Host 3 Wrd num: cmnt

Set the number of words to be displayed as a comment.

(Note) One word designates a character string divided by one or more spaces.

---Setting range---

- 0 to 100
- 0: Default value

【#9761】 Host 3 no total siz

Set whether to display the total number of characters registered in the machining programs of host1 when displaying the file list.

If there are many files in the directory to be referred to, the list can be updated quickly by setting "1".

- 0: Display
- 1: Not display

【#9771】 Host4 host name

Set the host computer name.

This parameter allows the NC to easily recognize the host computer on the network. Set the host computer's name (name registered in C:\windows\hosts) or the IP address.

<Setting example>

For host name: mspc160

For IP address: 150.40.0.111

(Note) Set the host computer's TCP/IP address if communication is not carried out correctly.

---Setting range---

15 characters (alphanumeric) or less

【#9772】 Host4 user name

Set the user name when logging into the host computer.

---Setting range---

15 characters (alphanumeric) or less

【#9773】 Host4 password

Set the password when logging into the host computer.

---Setting range---

15 characters (alphanumeric) or less

【#9774】 Host4 directory

Set the directory name of the host computer.

The directory released to the client (NC unit) with the host computer's server is handled as the root directory by the NC unit.

---Setting range---

31 characters (alphanumeric) or less

【#9775】 Host4 host type

Select the type of the host computer.

- 0: UNIX/PC automatic judgment
- 1: UNIX
- 2: PC (DOS)

(Note) When "0" is set, the settings for the following parameters will be invalid.

- #9776 Wrd pos: name
- #9777 Wrd pos: size
- #9778 Wrd pos: Dir
- #9779 Wrd pos: cmnt
- #9780 Wrd num: cmnt

【#9776】 Host 4 Wrd pos: name

Set the file name display position (nth word from left) of the list displayed when the ftp command "dir" is executed.

(Note) One word designates a character string divided by one or more spaces.

---Setting range---

- 0 to 100
- 0: Default value

【#9777】 Host 4 Wrd pos: size

Set the size display position (nth word from left) of the list displayed when the ftp command "dir" is executed.

(Note) One word designates a character string divided by one or more spaces.

---Setting range---
 0 to 100
 0: Default value

【#9778】 Host 4 Wrd pos: Dir

Set the <DIR> display position (nth word from left) of the list displayed when the ftp command "dir" is executed.

(Note) One word designates a character string divided by one or more spaces.

---Setting range---
 0 to 100
 0: Default value

【#9779】 Host 4 Wrd pos: cmnt

Set the comment (date, time, etc.) display position (nth word from left) of the list displayed when the ftp command "dir" is executed.

(Note) One word designates a character string divided by one or more spaces.

---Setting range---
 0 to 100
 0: Default value

【#9780】 Host 4 Wrd num: cmnt

Set the number of words to be displayed as a comment.

(Note) One word designates a character string divided by one or more spaces.

---Setting range---
 0 to 100
 0: Default value

【#9781】 Host 4 no total siz

Set whether to display the total number of characters registered in the machining programs of host1 when displaying the file list.

If there are many files in the directory to be referred to, the list can be updated quickly by setting "1".

0: Display
 1: Not display

【#10501 - 10530(PR)】 Monitr main menu 1 to 30

Set the menu Nos. to display the menu on Monitor screen's main menu using menu customization function.

The menu position of each parameter and the menu when "0" is set are as follows.

#10501: First from left in the page 1 (when "0" is set: Search)
 #10502: Second from left in the page 1 (when "0" is set: Research)
 #10503: Third from left in the page 1 (when "0" is set: Edit)
 #10504: Fourth from left in the page 1 (when "0" is set: Trace)
 #10505: Fifth from left in the page 1 (when "0" is set: Check)
 #10506: Sixth from left in the page 1 (when "0" is set: Cnt exp)
 #10507: Seventh from left in the page 1 (when "0" is set: Offset)
 #10508: Eighth from left in the page 1 (when "0" is set: Coord)
 #10509: Ninth from left in the page 1 (when "0" is set: Cnt set)
 #10510: Tenth from left in the page 1 (when "0" is set: MST)
 #10511: First from left in the page 2 (when "0" is set: Modal)
 #10512: Second from left in the page 2 (when "0" is set: Tree)
 #10513: Third from left in the page 2 (when "0" is set: Time)
 #10514: Fourth from left in the page 2 (when "0" is set: Com var)
 #10515: Fifth from left in the page 2 (when "0" is set: Loc var)
 #10516: Sixth from left in the page 2 (when "0" is set: P corr)
 #10517: Seventh from left in the page 2 (when "0" is set: PLC SW)
 #10518: Eighth from left in the page 2 (when "0" is set: G92 set)
 #10519: Ninth from left in the page 2 (when "0" is set: Col stp)
 #10520: Tenth from left in the page 2 (when "0" is set: LD MTR)
 #10521: First from left in the page 3 (when "0" is set: Sp-stby)
 #10522: Second from left in the page 3 (when "0" is set: TipDisp)
 #10523: Third from left in the page 3 (when "0" is set: All sp)
 #10524: Fourth from left in the page 3 (when "0" is set: MST)
 #10525: Fifth from left in the page 3 (when "0" is set: Not display)
 #10526: Sixth from left in the page 3 (when "0" is set: Not display)
 #10527: Seventh from left in the page 3 (when "0" is set: Not display)
 #10528: Eighth from left in the page 3 (when "0" is set: Not display)
 #10529: Ninth from left in the page 3 (when "0" is set: Not display)
 #10530: Tenth from left in the page 3 (when "0" is set: Not display)

-- Menu No. --
 -1: Not display
 0: Default
 1: Search
 2: Research
 3: Edit
 4: Trace
 5: Check
 6: Cnt exp
 7: Offset
 8: Coord
 9: Cnt set
 10: MST
 11: Modal
 12: Tree
 13: Time
 14: Com var
 15: Loc var
 16: P corr
 17: PLC SW
 18: G92 set
 19: Col stp
 20: LD MTR
 21: Sp-stby
 22: TipDisp
 23: All sp
 24: MST

(Note) If the menu No. for "Not display" is set for the main menu, that menu will not be displayed.

【#10551 - 10580(PR)】 Setup main menu 1 to 30

Set the menu Nos. to display the menu on Setup screen's main menu using menu customization function.

The menu position of each parameter and the menu when "0" is set are as follows.

- #10551: First from left in the page 1 (when "0" is set: T-ofs)
- #10552: Second from left in the page 1 (when "0" is set: T-meas)
- #10553: Third from left in the page 1 (when "0" is set: T-reg)
- #10554: Fourth from left in the page 1 (when "0" is set: T-life)
- #10555: Fifth from left in the page 1 (when "0" is set: Coord)
- #10556: Sixth from left in the page 1 (when "0" is set: W-meas)
- #10557: Seventh from left in the page 1 (when "0" is set: User)
- #10558: Eighth from left in the page 1 (when "0" is set: MDI)
- #10559: Ninth from left in the page 1 (when "0" is set: Cnt set)
- #10560: Tenth from left in the page 1 (when "0" is set: MST)
- #10561: First from left in the page 2 (when "0" is set: T-list)
- #10562: Second from left in the page 2 (when "0" is set: Pallet)
- #10563: Third from left in the page 2 (when "0" is set: Not display)
- #10564: Fourth from left in the page 2 (when "0" is set: Not display)
- #10565: Fifth from left in the page 2 (when "0" is set: Not display)
- #10566: Sixth from left in the page 2 (when "0" is set: Not display)
- #10567: Seventh from left in the page 2 (when "0" is set: Not display)
- #10568: Eighth from left in the page 2 (when "0" is set: Not display)
- #10569: Ninth from left in the page 2 (when "0" is set: Not display)
- #10570: Tenth from left in the page 2 (when "0" is set: Not display)
- #10571: First from left in the page 3 (when "0" is set: Not display)
- #10572: Second from left in the page 3 (when "0" is set: Not display)
- #10573: Third from left in the page 3 (when "0" is set: Not display)
- #10574: Fourth from left in the page 3 (when "0" is set: Not display)
- #10575: Fifth from left in the page 3 (when "0" is set: Not display)
- #10576: Sixth from left in the page 3 (when "0" is set: Not display)
- #10577: Seventh from left in the page 3 (when "0" is set: Not display)
- #10578: Eighth from left in the page 3 (when "0" is set: Not display)
- #10579: Ninth from left in the page 3 (when "0" is set: Not display)
- #10580: Tenth from left in the page 3 (when "0" is set: Not display)

- Menu No. --
- 1: Not display
- 0: Default
- 1: T-ofs
- 2: T-meas
- 3: T-reg
- 4: T-life
- 5: Coord
- 6: W-meas
- 7: User
- 8: MDI
- 9: Cnt set
- 10: MST
- 11: T-list
- 12: Pallet

(Note) If the menu No. for "Not display" is set for the main menu, that menu will not be displayed.

【#10601 - 10630(PR)】 Edit main menu 1 to 30

Set the menu Nos. to display the menu on Edit screen's main menu using menu customization function.

The menu position of each parameter and the menu when "0" is set are as follows.

#10601: First from left in the page 1 (when "0" is set: Edit)
 #10602: Second from left in the page 1 (when "0" is set: Check)
 #10603: Third from left in the page 1 (when "0" is set: NAVI)
 #10604: Fourth from left in the page 1 (when "0" is set: Not display)
 #10605: Fifth from left in the page 1 (when "0" is set: I/O)
 #10606: Sixth from left in the page 1 (when "0" is set: Not display)
 #10607: Seventh from left in the page 1 (when "0" is set: Not display)
 #10608: Eighth from left in the page 1 (when "0" is set: Not display)
 #10609: Ninth from left in the page 1 (when "0" is set: Not display)
 #10610: Tenth from left in the page 1 (when "0" is set: Not display)
 #10611: First from left in the page 2 (when "0" is set: Not display)
 #10612: Second from left in the page 2 (when "0" is set: Not display)
 #10613: Third from left in the page 2 (when "0" is set: Not display)
 #10614: Fourth from left in the page 2 (when "0" is set: Not display)
 #10615: Fifth from left in the page 2 (when "0" is set: Not display)
 #10616: Sixth from left in the page 2 (when "0" is set: Not display)
 #10617: Seventh from left in the page 2 (when "0" is set: Not display)
 #10618: Eighth from left in the page 2 (when "0" is set: Not display)
 #10619: Ninth from left in the page 2 (when "0" is set: Not display)
 #10620: Tenth from left in the page 2 (when "0" is set: Not display)
 #10621: First from left in the page 3 (when "0" is set: Not display)
 #10622: Second from left in the page 3 (when "0" is set: Not display)
 #10623: Third from left in the page 3 (when "0" is set: Not display)
 #10624: Fourth from left in the page 3 (when "0" is set: Not display)
 #10625: Fifth from left in the page 3 (when "0" is set: Not display)
 #10626: Sixth from left in the page 3 (when "0" is set: Not display)
 #10627: Seventh from left in the page 3 (when "0" is set: Not display)
 #10628: Eighth from left in the page 3 (when "0" is set: Not display)
 #10629: Ninth from left in the page 3 (when "0" is set: Not display)
 #10630: Tenth from left in the page 3 (when "0" is set: Not display)

-- Menu No. --
 -1: Not display
 0: Default
 1: Edit
 2: Check
 3: NAVI
 5: I/O

(Note) If the menu No. for "Not display" is set for the main menu, that menu will not be displayed.

【#10801】 Notice tel num 1

Set the call-back telephone No. used for one-touch call and operator notification.
 Begin with the No. from an area code for domestic call.
 Begin with a communication company No. for international call.
 Hyphens "-" can be used as a delimiting character.

---Setting range---
 Within 28 characters

【#10802】 Comment 1

Set a comment, such as a party's name, for the notification party telephone No.1.

---Setting range---
 Within 20 alphanumerical characters
 (excluding spaces)

【#10803】 Notice tel num 2

Set the call-back telephone No. used for one-touch call and operator notification.
Begin with the No. from an area code for domestic call.
Begin with a communication company No. for international call.
Hyphens "-" can be used as a delimiting character.

---Setting range---

Within 28 characters

【#10804】 Comment 2

Set a comment, such as a party's name, for the notification party telephone No.2.

---Setting range---

Within 20 alphanumerical characters
(excluding spaces)

【#10805】 Notice tel num 3

Set the call-back telephone No. used for one-touch call and operator notification.
Begin with the No. from an area code for domestic call.
Begin with a communication company No. for international call.
Hyphens "-" can be used as a delimiting character.

---Setting range---

Within 28 characters

【#10806】 Comment 3

Set a comment, such as a party's name, for the notification party telephone No.3.

---Setting range---

Within 20 alphanumerical characters
(excluding spaces)

【#10807】 Password

Set the password for sharing of machining data.

---Setting range---

4 characters (one-byte alphanumeric characters, without space)

【#10808】 Customer number

Set the user No. for sharing of machining data.

---Setting range---

Within 8 characters (one-byte alphanumeric characters, without space)

【#10812】 Anshin-net valid

Select whether to enable the Anshin-net function.

0: Disable
1: Enable

【#10813】 MTBnet enable

Select whether to enable the machine tool builder network system.

0: Disable
1: Enable
Standard setting: 0

(Note) Values other than "0" and "1" are invalid.

【#10814】 OP-notice condition

Select the condition of an NC for delivering an operator notification.

- 0: When the "automatic operation is starting" signal turns off. (Notifies the alarm if an alarm occurs, and if not, notifies the completion of machining.)
- 1: If the designated "#10971 Complete condition" changes into "#10972 Complete CND num", or the "automatic operation is starting" signal turns off due to an alarm. (Notifies the alarm if an alarm occurs at the change of device condition, and if not, notifies the completion of machining.)
- 2: When the "automatic operation is starting" signal turns off due to an alarm.

【#10815】 OP-notice mode

Select whether to cancel the mode after delivering an operator notification.

- 0: Cancel
- 1: Not cancel. Cancel the mode by screen operation.

【#11005(PR)】 PC IP address IP address setting

Set the IP address for the display unit or PC in which machining programs are stored.

Set the IP address for the display unit on which the automatic power OFF will be executed.

When the 3D machine interference check function is enabled, set the IP address of the display unit that is used for the 3D machine interference check (for M700VW only).

(Note 1) When "0.0.0.0" is input, "192.168.100.2" is automatically set.

(Note 2) This parameter is valid only for M700VW/M700 Series.

PC Subnet

Set the subnet mask for the display unit or PC in which machining programs are stored.

PC Gateway

Set the gateway for the display unit or PC in which machining programs are stored.

【#19001】 Syn.tap(,S)cancel

0: Retain the spindle speed (,S) in synchronous tap return

1: Cancel the spindle speed (,S) in synchronous tap return with G80

The same value as "#1223 aux07/bit6" will be reflected. When either setting changes, the other will change accordingly.

【#19002】 Zero-point mark

Select the position for displaying the zero point mark in the graphic trace and 2D check.

0: Machine coordinates zero point (same as conventional method)

1: Workpiece coordinate zero point

The same value as "#1231 set03/bit4" will be reflected. When either setting changes, the other will change accordingly.

【#19003】 PRG coord rot type

Select the start point of the initial travel command after program coordinate rotation command.

0: Calculate the end position using the current position on the local coordinate system before rotating, without rotating the start point in accordance with the coordinates rotation.

1: Calculate the end position, assuming that the start point rotates in accordance with the coordinates rotation.

【#19004】 Tap feedrate limit

Set the upper limit of the cutting feed rate in synchronous tapping.

---Setting range---

0 to 1000(mm/rev)

(Note)Setting "0" disables this parameter.

When the commanded cutting feed rate in synchronous tapping exceeds this setting, a program error (P184) will occur.

【#19005】 manual Fcmd2 clamp

Set a clamp speed coefficient (%) for manual speed command 2.
 The feed rate is clamped at the command feed rate or rapid traverse rate for automatic operation, which was multiplied by this parameter's value.
 (Note) This setting is valid only for manual speed command 2.

- Setting range---
 0 to 1000 (%)
 0: 100% (Default value)

【#19006(PR)】 EOR Disable

Set whether to handle an EOR(%) in machining program as the end of program in automatic operation, graphic check, program transfer to NC memory, program editing, and buffer correction. Tape operation, Computer Link B, and serial input/output are not included.
 0: An EOR(%) is handled as the end of machining program.
 1: An EOR(%) is not handled as the end of machining program. The program will be read to the end of file.

【#19008】 PRM coord rot type

Select the start point of the initial travel command after parameter coordinate rotation.
 0: Calculate the end position, assuming that the start point rotates in accordance with the coordinates rotation.
 1: Calculate the end position using the current position on the local coordinate system before rotating, without rotating the start point in accordance with the coordinates rotation.

【#19401】 G33.n chamfer spd

Not used.

【#19405】 Rotary ax drawing

Specify this parameter to draw a path of C axis (rotary axis) according to its rotation in the graphic trace and 2D graphic trace.
 When "#1013 axname" is set to "C", the axis is handled as a rotary axis.
 By setting this parameter to "C", a rotation path around the Z axis on actual workpiece can be expressed.
 When the Graphic check rotary axis drawing option or Graphic trace rotary axis drawing option is disabled, this parameter is ignored.
 C : Enable this function
 0 : Disable this function
 (Setting is cleared when "0" is set)

【#19406】 Hob retract ON at alarm

Select whether to enable the retract at an alarm during hobbing.
 0 : Disable
 1 : Enable

【#19407】 Hob retract acceleration deceleration OFF

Select whether to disable the acceleration/deceleration of a retract.
 0 : Enable
 1 : Disable

【#19417】 Hole dec check 2

This is enabled when #1253 set25 bit2 is 1.
 The operation at the hole bottom and the hole drilling stop position is as below.
 0: Perform no deceleration check.
 1: Perform command deceleration check.
 2: Perform in-position check.
 <Target fixed cycles>
 Machining center: G81, G82, G83, G73
 Lathe : G83, G87, G83.2

【#19425】 ManualB Std R1

Set a radius used as standard for the rotary axis speed.

When the setting value of #19425 is larger than that of "#19427 ManualB Std R2", #19425 setting will be used as surface speed control standard radius 2: #19427 setting will be used as surface speed control standard radius 1.

---Setting range---

0 to 99999.999 (mm)

【#19426】 ManualB Std F1

This sets the rotary axis speed for surface speed control standard radius 1 (ManualB Std R1).

When the setting value of #19426 is larger than that of "#19428 ManualB Std F2", #19426 setting will be used as surface speed control standard speed 2: #19427 setting will be used as surface speed control standard speed 1.

---Setting range---

1 to 1000000 (°/min)

【#19427】 ManualB Std R2

Set a radius used as standard for the rotary axis speed.

When the same value is set as "#19425 ManualB Std R1", the surface speed control standard speed 1 (ManualB Std F1) will be selected as the rotary axis speed if the radius is less than that value. The surface speed control standard speed 2 (ManualB Std F2) is selected if larger than the set value.

---Setting range---

0 to 99999.999 (mm)

【#19428】 ManualB Std F2

Set the rotary axis speed for surface speed control standard radius 2 (ManualB Std R2).

---Setting range---

1 to 1000000 (°/min)

Revision History

Date of revision	Manual No.	Revision details
Mar. 2013	IB(NA)1501186-A	First edition created.
Mar. 2014	IB(NA)1501186-B	<p>- Added/Changed the following chapters in order to support the system software K1 version.</p> <p>The following chapters are added.</p> <p>II MACHINE OPERATIONS</p> <p>7.1.4 Changing the Area for the Stored Stroke Limit I</p> <p>7.4 System Lock</p> <p>The following chapters were revised.</p> <p>I SCREEN OPERATIONS</p> <p>1.12 Menu Customization Function</p> <p>2.8 Tool Compensation Amount</p> <p>2.10 Workpiece Coordinate System Compensation</p> <p>3.2.1 Tool Compensation Amount (M system)</p> <p>3.2.2.1 Wear Data</p> <p>3.2.2.2 Tool Length Data</p> <p>3.2.2.3 Tool Nose Data</p> <p>3.3.1 Tool Measurement (M system)</p> <p>3.3.2 Tool Measurement (L system)</p> <p>3.5.2 Displaying the Life Management Data in Group Units (M system)</p> <p>4.2 Program Editing</p> <p>4.4 Program Input/Output</p> <p>6.2 Input/Output Screen</p> <p>III MAINTENANCE</p> <p>2.1 Durable Parts</p> <p>4.1 Durable Parts</p> <p>I SCREEN OPERATIONS</p> <p>5.8 Data Sampling Screen</p> <p>Reviewed and revised the construction of sections.</p> <p>- Mistakes are corrected.</p>

Global Service Network

AMERICA

MITSUBISHI ELECTRIC AUTOMATION INC. (AMERICA FA CENTER)

Central Region Service Center
500 CORPORATE WOODS PARKWAY, VERNON HILLS, ILLINOIS 60061, U.S.A.
TEL: +1-847-478-2500 / FAX: +1-847-478-2650

Michigan Service Satellite
ALLEGAN, MICHIGAN 49010, U.S.A.
TEL: +1-847-478-2500 / FAX: +1-847-478-2650

Ohio Service Satellite
LIMA, OHIO 45901, U.S.A.
TEL: +1-847-478-2500 / FAX: +1-847-478-2650
CINCINNATI, OHIO 45201, U.S.A.
TEL: +1-847-478-2500 / FAX: +1-847-478-2650

Minnesota Service Satellite
ROGERS, MINNESOTA 55374, U.S.A.
TEL: +1-847-478-2500 / FAX: +1-847-478-2650

West Region Service Center
16900 VALLEY VIEW AVE., LAMIRADA, CALIFORNIA 90638, U.S.A.
TEL: +1-714-699-2625 / FAX: +1-847-478-2650

Northern CA Satellite
SARATOGA, CALIFORNIA 95070, U.S.A.
TEL: +1-714-699-2625 / FAX: +1-847-478-2650

Pennsylvania Service Satellite
PITTSBURG, PENNSYLVANIA 15644, U.S.A.
TEL: +1-732-560-4500 / FAX: +1-732-560-4531

Connecticut Service Satellite
TORRINGTON, CONNECTICUT 06790, U.S.A.
TEL: +1-732-560-4500 / FAX: +1-732-560-4531

South Region Service Center
1845 SATTELITE BOULEVARD STE. 450, DULUTH, GEORGIA 30097, U.S.A.
TEL: +1-678-258-4529 / FAX: +1-678-258-4519

Texas Service Satellites
GRAPEVINE, TEXAS 76051, U.S.A.
TEL: +1-678-258-4529 / FAX: +1-678-258-4519
HOUSTON, TEXAS 77001, U.S.A.
TEL: +1-678-258-4529 / FAX: +1-678-258-4519

Tennessee Service Satellite
Nashville, Tennessee, 37201, U.S.A.
TEL: +1-678-258-4529 / FAX: +1-678-258-4519

Florida Service Satellite
WEST MELBOURNE, FLORIDA 32904, U.S.A.
TEL: +1-678-258-4529 / FAX: +1-678-258-4519

Canada Region Service Center
4299 14TH AVENUE MARKHAM, ONTARIO L3R 0J2, CANADA
TEL: +1-905-475-7728 / FAX: +1-905-475-7935

Canada Service Satellite
EDMONTON, ALBERTA T5A 0A1, CANADA
TEL: +1-905-475-7728 / FAX: +1-905-475-7935

Mexico Region Service Center
MARIANO ESCOBEDO 69 TLALNEPANTLA, 54030 EDO. DE MEXICO
TEL: +52-55-3067-7500 / FAX: +52-55-9171-7649

Monterrey Service Satellite
MONTERREY, N.L., 64720, MEXICO
TEL: +52-81-8365-4171

BRAZIL

MELCO CNC do Brasil Comércio e Serviços S.A

Brazil Region Service Center
ACESSO JOSE SARTORELLI, KM 2.1 CEP 18550-000, BOITUVA-SP, BRAZIL
TEL: +55-15-3363-9900 / FAX: +55-15-3363-9911

EUROPE

MITSUBISHI ELECTRIC EUROPE B.V.
GOTHAER STRASSE 10, 40880 RATINGEN, GERMANY
TEL: +49-2102-486-0 / FAX: +49-2102-486-5910

Germany Service Center
KURZE STRASSE, 40, 70794 FILDERSTADT-BONLANDEN, GERMANY
TEL: +49-711-770598-123 / FAX: +49-711-770598-141

France Service Center DEPARTEMENT CONTROLE NUMERIQUE
25, BOULEVARD DES BOUVETS, 92741 NANTERRE CEDEX FRANCE
TEL: +33-1-41-02-83-13 / FAX: +33-1-49-01-07-25

France (Lyon) Service Satellite DEPARTEMENT CONTROLE NUMERIQUE
120, ALLEE JACQUES MONOD 69800 SAINT PRIEST FRANCE
TEL: +33-1-41-02-83-13 / FAX: +33-1-49-01-07-25

Italy Service Center
VIALE COLLEONI, 7 - CENTRO DIREZIONALE COLLEONI PALAZZO SIRIO INGRESSO 1
20864 AGRATE BRIANZA (MB), ITALY
TEL: +39-039-6053-342 / FAX: +39-039-6053-206

Italy (Padova) Service Satellite
VIA G. SAVELLI, 24 - 35129 PADOVA, ITALY
TEL: +39-039-6053-342 / FAX: +39-039-6053-206

U.K. Branch
TRAVELLERS LANE, HATFIELD, HERTFORDSHIRE, AL10 8XB, U.K.
TEL: +49-2102-486-0 / FAX: +49-2102-486-5910

Spain Service Center
CTRA. DE RUBI, 76-80-APDO. 420
08173 SAINT CUGAT DEL VALLES, BARCELONA SPAIN
TEL: +34-935-65-2236 / FAX: +34-935-65-1579

Poland Service Center
UL. KRAKOWSKA 50, 32-083 BALICE, POLAND
TEL: +48-12-630-4700 / FAX: +48-12-630-4701

Mitsubishi Electric Turkey A.Ş Ümraniye Şubesi
Turkey Service Center
ŞERİFALİ MAH. NUTUK SOK. NO.5 34775
ÜMRANIYE, İSTANBUL, TURKEY
TEL: +90-216-526-3990 / FAX: +90-216-526-3995

Czech Republic Service Center
KAFKOVA 1853/3, 702 00 OSTRAVA 2, CZECH REPUBLIC
TEL: +420-59-5691-185 / FAX: +420-59-5691-199

Russia Service Center
213, B.NOVOODMITROVSKAYA STR., 14/2, 127015 MOSCOW, RUSSIA
TEL: +7-495-748-0191 / FAX: +7-495-748-0192

MITSUBISHI ELECTRIC EUROPE B.V. (SCANDINAVIA)
Sweden Service Center
HAMMARBACKEN 14 191 49 SOLLENTUNA, SWEDEN
TEL: +46-8-6251000 / FAX: +46-8-966877

Bulgaria Service Center
4 A.LYAPCHEV BOUL., POB 21, BG-1756 SOFIA, BULGARIA
TEL: +359-2-8176009 / FAX: +359-2-9744061

Ukraine (Kharkov) Service Center
APTEKARSKIY LANE 9-A, OFFICE 3, 61001 KHARKOV, UKRAINE
TEL: +380-57-732-7774 / FAX: +380-57-731-8721

Ukraine (Kiev) Service Center
4-B, M. RASKOVOYI STR., 02660 KIEV, UKRAINE
TEL: +380-44-494-3355 / FAX: +380-44-494-3366

Belarus Service Center
OFFICE 9, NEZAVISIMOSTI PR.177, 220125 MINSK, BELARUS
TEL: +375-17-393-1177 / FAX: +375-17-393-0081

South Africa Service Center
5 ALBATROSS STREET, RHODESFIELD, KEMPTON PARK 1619, GAUTENG, SOUTH AFRICA
TEL: +27-11-394-8512 / FAX: +27-11-394-8513

ASEAN**MITSUBISHI ELECTRIC ASIA PTE. LTD. (ASEAN FA CENTER)**

Singapore Service Center
307 ALEXANDRA ROAD #05-01/02 MITSUBISHI ELECTRIC BUILDING SINGAPORE 159943
TEL: +65-6473-2308 / FAX: +65-6476-7439

Malaysia (KL) Service Center
60, JALAN USJ 10/1B 47620 UEP SUBANG JAYA SELANGOR DARUL EHSAN, MALAYSIA
TEL: +60-3-5631-7605 / FAX: +60-3-5631-7636

Malaysia (Johor Baru) Service Center
17 & 17A, JALAN IMPIAN EMAS 5/5, TAMAN IMPIAN EMAS, 81300 SKUDAI, JOHOR MALAYSIA.
TEL: +60-7-557-8218 / FAX: +60-7-557-3404

Philippines Service Center
UNIT NO.411, ALABANG CORPORATE CENTER KM 25, WEST SERVICE ROAD
SOUTH SUPERHIGHWAY, ALABANG MUNTINLUPA METRO MANILA, PHILIPPINES 1771
TEL: +63-2-807-2416 / FAX: +63-2-807-2417

VIETNAM**MITSUBISHI ELECTRIC VIETNAM CO.,LTD**

Vietnam (Ho Chi Minh) Service Center
UNIT 01-04, 10TH FLOOR, VINCOM CENTER 72 LE THANH TON STREET, DISTRICT 1,
HO CHI MINH CITY, VIETNAM
TEL: +84-8-3910 5945 / FAX: +84-8-3910 5946

Vietnam (Hanoi) Service Satellite
SUITE 9-05, 9TH FLOOR, HANOI CENTRAL OFFICE BUILDING, 44B LY THUONG KIET STREET,
HOAN KIEM DISTRICT, HANOI CITY, VIETNAM
TEL: +84-4-3937-8075 / FAX: +84-4-3937-8076

INDONESIA**PT. MITSUBISHI ELECTRIC INDONESIA**

Indonesia Service Center
GEDUNG JAYA 11TH FLOOR, JL. MH. THAMRIN NO.12, JAKARTA PUSAT 10340, INDONESIA
TEL: +62-21-3192-6461 / FAX: +62-21-3192-3942

THAILAND**MITSUBISHI ELECTRIC FACTORY AUTOMATION (THAILAND) CO.,LTD**

Thailand Service Center
12TH FLOOR, SV.CITY BUILDING, OFFICE TOWER 1, NO. 896/19 AND 20 RAMA 3 ROAD,
KWAENG BANGPONGPANG, KHET YANNAWA, BANGKOK 10120, THAILAND
TEL: +66-2-682-6522-31 / FAX: +66-2-682-6020

INDIA**MITSUBISHI ELECTRIC INDIA PVT. LTD.**

India Service Center
2nd FLOOR, TOWER A & B, DLF CYBER GREENS, DLF CYBER CITY,
DLF PHASE-III, GURGAON 122 002, HARYANA, INDIA
TEL: +91-124-4630 300 / FAX: +91-124-4630 399

Ludhiana satellite office
Jamshedpur satellite office

India (Pune) Service Center
EMERALD HOUSE, EL-3, J-BLOCK, MIDC BHOSARI, PUNE – 411 026, MAHARASHTRA, INDIA
TEL: +91-20-2710 2000 / FAX: +91-20-2710 2100

Baroda satellite office
Mumbai satellite office

India (Bangalore) Service Center
PRESTIGE EMERALD, 6TH FLOOR, MUNICIPAL NO. 2,
LAVELLE ROAD, BANGALORE - 560 043, KAMATAKA, INDIA
TEL: +91-80-4020-1600 / FAX: +91-80-4020-1699

Chennai satellite office
Coimbatore satellite office

OCEANIA**MITSUBISHI ELECTRIC AUSTRALIA LTD.**

Australia Service Center
348 VICTORIA ROAD, RYDALMERE, N.S.W. 2116 AUSTRALIA
TEL: +61-2-9684-7269 / FAX: +61-2-9684-7245

CHINA**MITSUBISHI ELECTRIC AUTOMATION (CHINA) LTD. (CHINA FA CENTER)**

China (Shanghai) Service Center
1-3.5-10,18-23/F, NO.1386 HONG QIAO ROAD, CHANG NING QU,
SHANGHAI 200336, CHINA
TEL: +86-21-2322-3030 / FAX: +86-21-2308-3000

China (Ningbo) Service Dealer
China (Wuxi) Service Dealer
China (Jinan) Service Dealer
China (Hangzhou) Service Dealer
China (Wuhan) Service Satellite

China (Beijing) Service Center
9/F, OFFICE TOWER 1, HENDERSON CENTER, 18 JIANGUOMENNEI DAJIE,
DONGCHENG DISTRICT, BEIJING 100005, CHINA
TEL: +86-10-6518-8830 / FAX: +86-10-6518-8030

China (Beijing) Service Dealer

China (Tianjin) Service Center
UNIT 2003, TIANJIN CITY TOWER, NO 35 YOUYI ROAD, HEXI DISTRICT,
TIANJIN 300061, CHINA
TEL: +86-22-2813-1015 / FAX: +86-22-2813-1017

China (Shenyang) Service Satellite
China (Changchun) Service Satellite

China (Chengdu) Service Center
ROOM 407-408, OFFICE TOWER AT SHANGRI-LA CENTER, NO. 9 BINJIANG DONG ROAD,
JINJIANG DISTRICT, CHENGDU, SICHUAN 610021, CHINA
TEL: +86-28-8446-8030 / FAX: +86-28-8446-8630

China (Shenzhen) Service Center
ROOM 2512-2516, 25/F., GREAT CHINA INTERNATIONAL EXCHANGE SQUARE, JINTIAN RD.S.,
FUTIAN DISTRICT, SHENZHEN 518034, CHINA
TEL: +86-755-2399-8272 / FAX: +86-755-8218-4776

China (Xiamen) Service Dealer
China (Dongguan) Service Dealer

KOREA**MITSUBISHI ELECTRIC AUTOMATION KOREA CO., LTD. (KOREA FA CENTER)**

Korea Service Center
1480-6, GAYANG-DONG, GANGSEO-GU, SEOUL 157-200, KOREA
TEL: +82-2-3660-9602 / FAX: +82-2-3664-8668

Korea Taegu Service Satellite
4F KT BUILDING, 1630 SANGYEOK-DONG, BUK-KU, DAEGU 702-835, KOREA
TEL: +82-53-382-7400 / FAX: +82-53-382-7411

TAIWAN**MITSUBISHI ELECTRIC TAIWAN CO., LTD. (TAIWAN FA CENTER)**

Taiwan (Taichung) Service Center (Central Area)
NO.8-1, INDUSTRIAL 16TH RD., TAICHUNG INDUSTRIAL PARK, SITUN DIST.,
TAICHUNG CITY 40768, TAIWAN R.O.C.
TEL: +886-4-2359-0688 / FAX: +886-4-2359-0689

Taiwan (Taipei) Service Center (North Area)
10F, NO.88, SEC.6, CHUNG-SHAN N. RD., SHI LIN DIST., TAIPEI CITY 11155, TAIWAN R.O.C.
TEL: +886-2-2833-5430 / FAX: +886-2-2833-5433

Taiwan (Tainan) Service Center (South Area)
11F-1., NO.30, ZHONGZHENG S. ROAD, YONGKANG DISTRICT, TAINAN CITY 71067, TAIWAN, R.O.C
TEL: +886-6-252-5030 / FAX: +886-6-252-5031

Notice

Every effort has been made to keep up with software and hardware revisions in the contents described in this manual. However, please understand that in some unavoidable cases simultaneous revision is not possible. Please contact your Mitsubishi Electric dealer with any questions or comments regarding the use of this product.

Duplication Prohibited

This manual may not be reproduced in any form, in part or in whole, without written permission from Mitsubishi Electric Corporation.

© 2013-2014 MITSUBISHI ELECTRIC CORPORATION
ALL RIGHTS RESERVED.

MITSUBISHI CNC



MODEL	E70 Series
MODEL CODE	100-338
Manual No.	IB-1501186